

VICINITY MAP

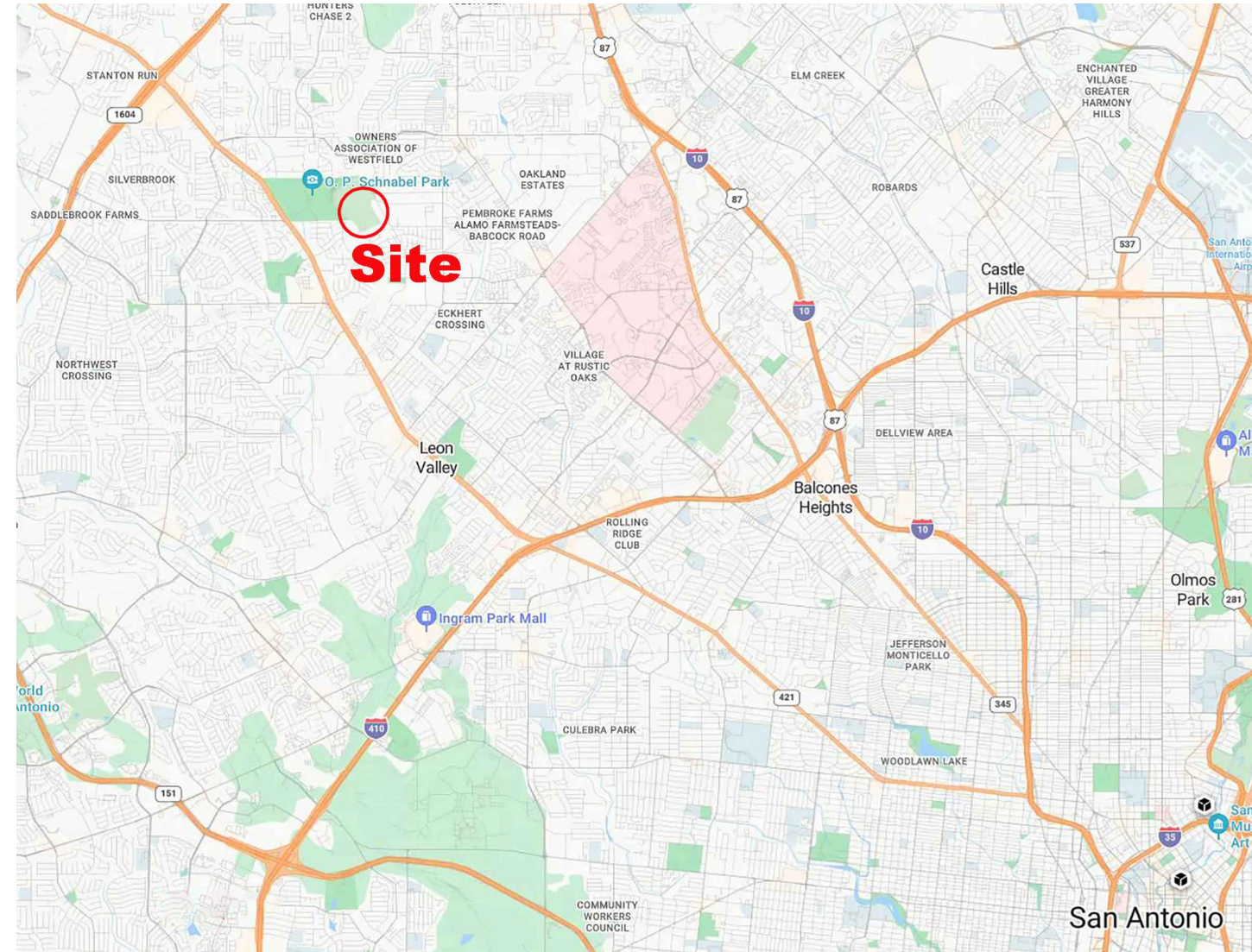

O.P. SCHNABEL BIKE PARK

Bike Park Area Site Development & Greenway Trail Connection

2022 Bond Improvements

9700 Rochelle Road, San Antonio, Tx 78240
CoSA Permit: AP # _____



INDEX TO DRAWINGS:

PARK SITE DEVELOPMENT SHEET INDEX

COVER	(THIS SHEET)
SD-00	GENERAL INFORMATION
SD-1.0	SITE DEVELOPMENT REFERENCE PLAN
SD-1.1	SITE DEVELOPMENT PLAN: NORTH BIKE PARK AREA
SD-1.2	SITE DEVELOPMENT PLAN: EAST BIKE PARK AREA
SD-1.3	SITE DEVELOPMENT PLAN: WEST BIKE PARK AREA
SD-2.0	SITE DETAILS: CONCRETE PAVEMENT
SD-2.1	SITE DETAILS: STRUCTURES
SD-2.2	SITE DETAILS: STRUCTURES
STP-1.0*	TREE PRESERVATION PLANS
STP-2.0*	TREE PRESERVATION DETAILS & NOTES
LP-1.0*	LANDSCAPE PLANTING PLAN & SCHEDULE
LP-2.0*	PLANTING NOTES
LP-2.1*	PLANTING DETAILS
EPIC*	ENVIRONMENTAL PERMITS, ISSUES & COMMITMENTS
SWP3*	STORMWATER POLLUTION PREVENTION PLAN
EE-000*	ELECTRICAL SYM. & ABBREV.
EE001*	ELECTRICAL DETAILS
E100*	ELECTRICAL SITE PLAN
E200*	ELEC. ONE-LINE DIAGRAM
	*TO FOLLOW IN CD PHASE

BIKE PARK SHEET INDEX

BP-01.01	BIKE PARK GENERAL NOTES
BP-01.02	FLOW TRAIL NOTES
BP-01.03	FLOW TRAIL NOTES
BP-01.04	SKILLS COURSE NOTES
BP-02.01	BIKE PARK REFERENCE PLAN
BP-03.01	FLOW LINES REFERENCE PLAN
BP-03.02	FLOW LINES MATERIALS PLAN
BP-03.03	FLOW LINES GRADING PLAN
BP-03.04	FLOW LINES LAYOUT PLAN
BP-03.05	FLOW LINES LAYOUT TABLE
BP-04.01	SKILLS COURSE
BP-04.02	SKILLS COURSE MATERIALS PLAN
BP-04.03	SKILLS COURSE GRADING PLAN
BP-04.04	SKILLS COURSE LAYOUT PLAN
BP-04.05	SKILLS COURSE LAYOUT TABLE
BP-05.01	FLOW LINE DETAILS
BP-05.02	FLOW LINE DETAILS
BP-05.03	FLOW LINE DETAILS
BP-05.04	FLOW LINE DETAILS
BP-05.05	FLOW LINE DETAILS
BP-06.01	SKILLS COURSE DETAILS
BP-06.02	SKILLS COURSE DETAILS
BP-06.03	SKILLS COURSE DETAILS
BP-06.04	SKILLS COURSE DETAILS
BP-07.01	WAYFINDING DETAILS
BP-07.02	WAYFINDING DETAILS

Public Works Project Manager
Mark Wittlinger - Project Manager
 City of San Antonio, Public Works Dept.
100 W. Houston St, Street Level | San Antonio, TX 78205
P.O. Box 839966 | San Antonio, TX 78283-3966
 Phone: (210) 207-2874 Email: Mark.Wittlinger@san.antonio.gov

CITY MANAGER
 Erik Walsh

PARKS & RECREATION DIRECTOR
 Homer Garcia, III

DIRECTOR OF PUBLIC WORKS / CITY ENGINEER
 Rozi Hosseini, P.E.

CITY COUNCIL
MAYOR
 Ron Nirenberg

COUNCIL

Sukh Kaur	District 1	Mellisa Cabello Hvarda	District 6
Jalen McKee-Rodriguez	District 2	Marina Alderete Gavito	District 7
Phyllis Viagran	District 3	Manny Pelaez	District 8
Adriana Rocha Garcia	District 4	John Courage	District 9
Teri Castillo	District 5	Mark Whyte	District 10



LANDSCAPE ARCHITECT / PRIME CONSULTANT
BENDER WELLS CLARK DESIGN
 830 N. ALAMO ST.
 SAN ANTONIO, TEXAS 78215
 (210) 692-9221 FAX (210) 223-8582

**DESIGN
 DEVELOPMENT
 SUBMITTAL
 DOCUMENTS**

Date: Jan 05, 2024, 2:03pm User ID: lclark
 File: S:\2022 PROJECTS\OP Schnabel Bike Park\Workfile\2024-1-4 OPS SCH DD BASE.dwg

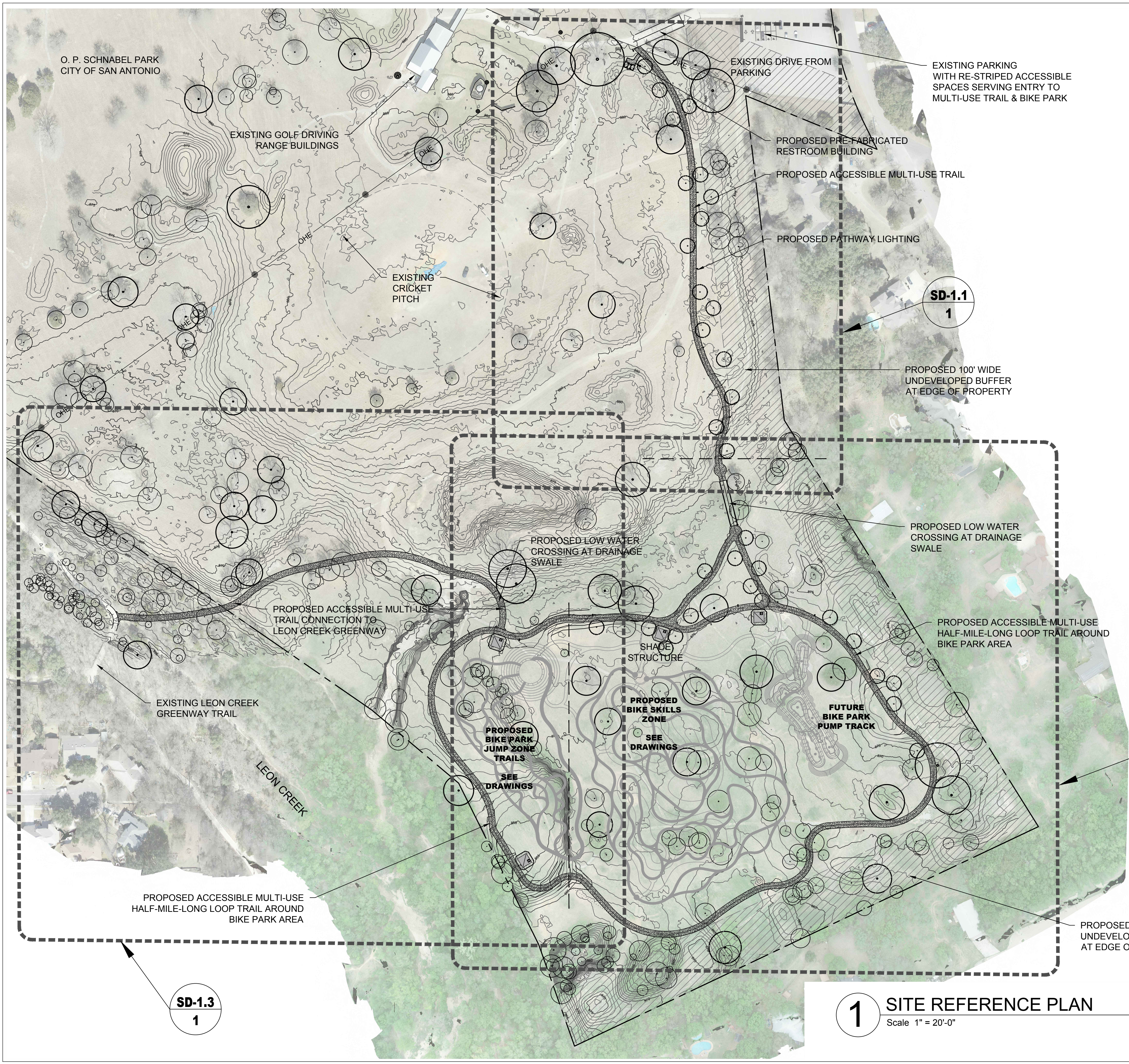

1 SITE REFERENCE PLAN
 Scale 1" = 20'-0"

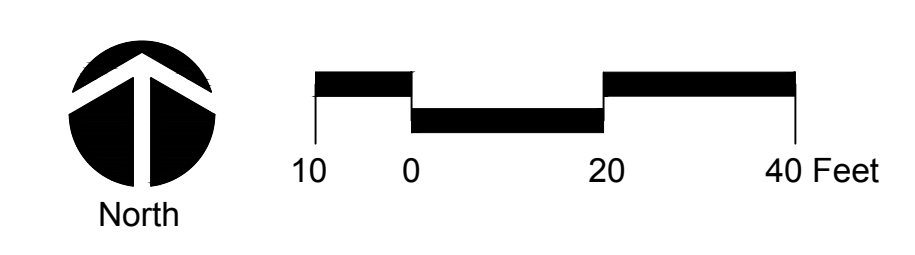

DESIGN
 DEVELOPMENT
 SUBMITTAL
 DOCUMENTS

ISSUED SETS	
Date	Description

REVISIONS		
No.	Date	Description

LANDSCAPE ARCHITECT
BENDER WELLS CLARK DESIGN
 830 N. ALAMO ST.
 SAN ANTONIO, TEXAS 78215

LANDSCAPE ARCHITECTURE
URBAN DESIGN
PLANNING

830 North Alamo Street
 San Antonio, Texas 78215
 210-692-9221
 www.bwcdesign.com

© 2024 Bender Wells Clark Design
 All rights reserved. No part of this document may be reproduced or utilized in any form without prior written authorization of Bender Wells Clark Design.

**O. P. Schnabel Bike Park
 Bike Park
 2022 Bond Improvements**

**9700 Rochelle Road
 San Antonio Tx 78240**

The drawings are designed specifically for this site and shall not apply to any other projects. The reproduction and use of these drawings for other projects is prohibited. Use of this set of drawings requires appropriate authorization from Bender Wells Clark Design.

LANDSCAPE ARCHITECT'S LICENSURE

THESE DOCUMENTS ARE INCOMPLETE AND ARE RELEASED FOR INTERIM REVIEW ONLY, AND NOT INTENDED FOR REGULATORY APPROVAL, BIDDING, PERMIT, OR CONSTRUCTION PURPOSES.

Drawn By :

SHEET TITLE & NUMBER:
**Site Reference
 Plan: Overall Bike
 Park Area**

SD-1.0

Date: Jan 05, 2024, 2:03pm User ID: lclark
 File: S:\2022 PROJECTS\OP Schnabel Bike Park\Workfile\2024-1-4 OPS SCH DD BASE.dwg

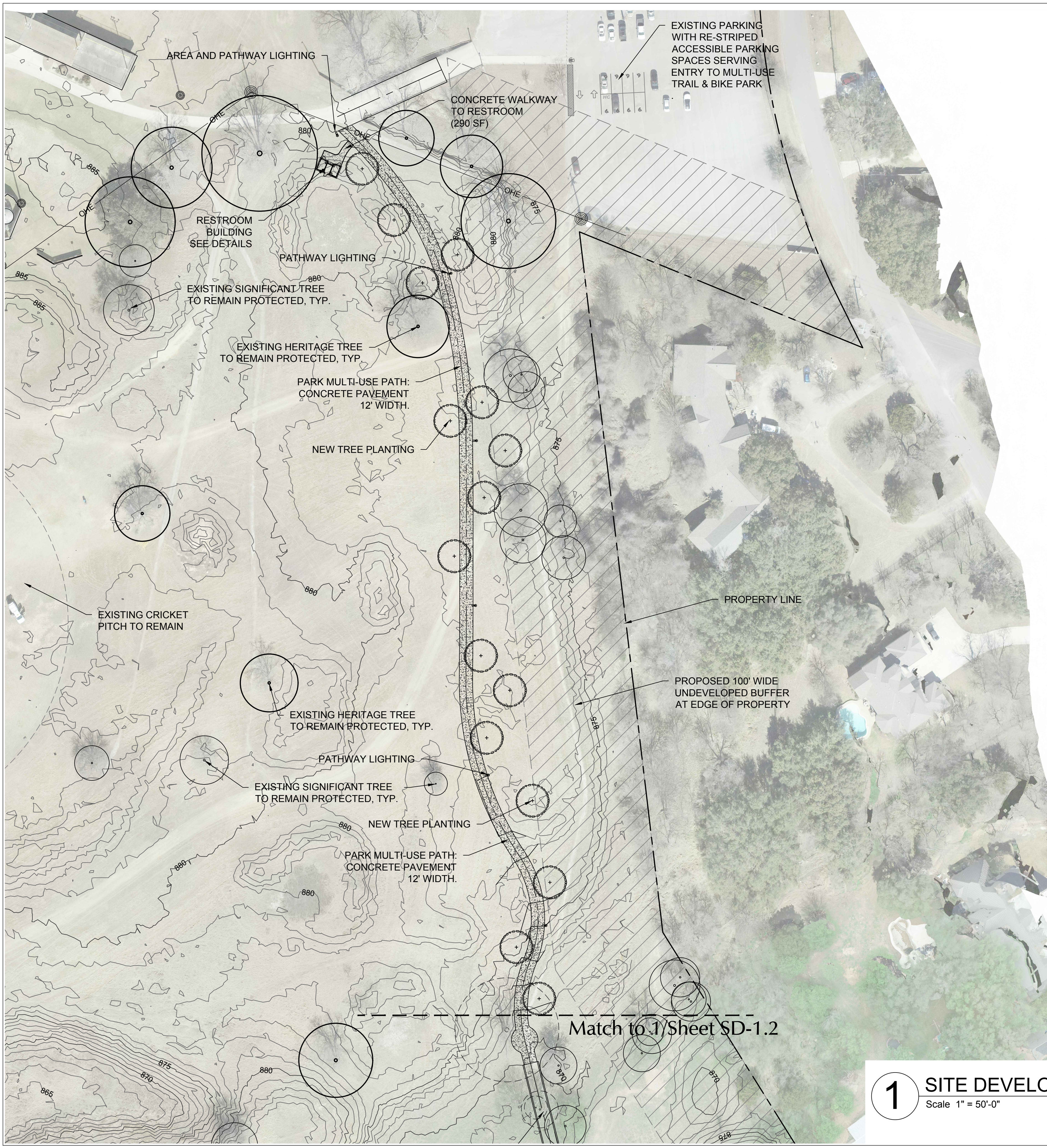

1 SITE DEVELOPMENT PLAN: NORTH AREA
 Scale 1" = 50'-0"

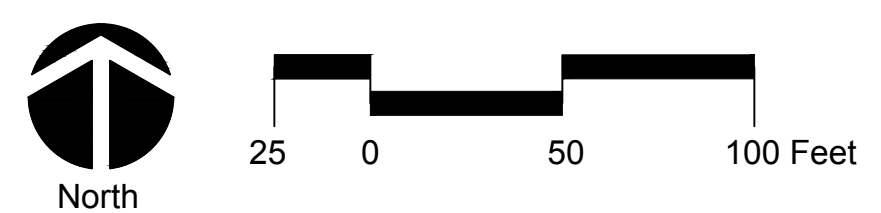

DESIGN
 DEVELOPMENT
 SUBMITTAL
 DOCUMENTS

ISSUED SETS	
Date	Description

REVISIONS		
No.	Date	Description

LANDSCAPE ARCHITECT
BENDER WELLS CLARK DESIGN
 830 N. ALAMO ST.
 SAN ANTONIO, TEXAS 78215

**LANDSCAPE
 ARCHITECTURE**
URBAN DESIGN
PLANNING

830 North Alamo Street
 San Antonio, Texas 78215
 210-692-9221
 www.bwcdesign.com

© 2024 Bender Wells Clark Design
 All rights reserved. No part of this document may be reproduced or utilized in any form without prior written authorization of Bender Wells Clark Design.

**O. P. Schnabel Bike Park
 Bike Park
 2022 Bond Improvements**

**9700 Rochelle Road
 San Antonio Tx 78240**

The drawings and design are prepared specifically for this site and shall not apply to any other projects. The reproduction and use of these drawings for other projects is prohibited. Use of this set of drawings requires appropriate authorization from Bender Wells Clark Design.

LANDSCAPE ARCHITECT'S LICENSURE

THESE DOCUMENTS ARE
 INCOMPLETE AND ARE RELEASED
 FOR INTERIM REVIEW ONLY, AND
 NOT INTENDED FOR REGULATORY
 APPROVAL, BIDDING, PERMIT, OR
 CONSTRUCTION PURPOSES.

Drawn By : _____

SHEET TITLE & NUMBER:
**Site Development
 Plan: North Bike Park
 Area**

SD-1.1

Date: Jan 05, 2024, 2:05pm User ID: lclark
 File: S:\2022 PROJECTS\OP Schnabel Bike Park\Workfile\2024-1-4 OPS SCH DD BASE.dwg



1 SITE DEVELOPMENT PLAN: EAST AREA
 Scale 1" = 50'-0"

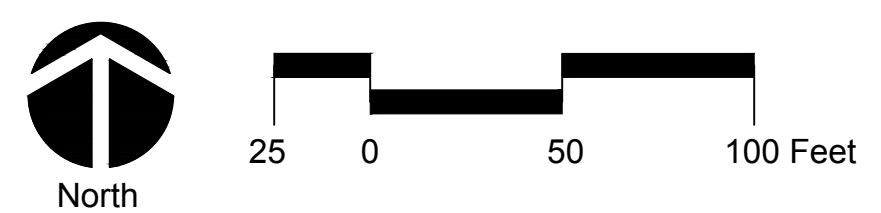

DESIGN
 DEVELOPMENT
 SUBMITTAL
 DOCUMENTS

ISSUED SETS	
Date	Description

REVISIONS		
No.	Date	Description

LANDSCAPE ARCHITECT
 BENDER WELLS CLARK DESIGN
 830 N. ALAMO ST.
 SAN ANTONIO, TEXAS 78215

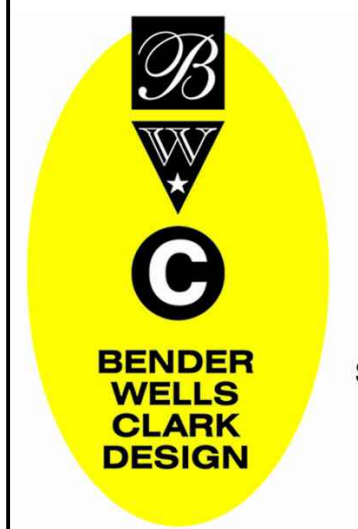

**Landscape
 Architecture**
Urban Design
Planning
 830 North Alamo Street
 San Antonio, Texas 78215
 210-692-9221
 www.bwcdesign.com

© 2024 Bender Wells Clark Design
 All rights reserved. No part of this document may be reproduced or utilized in any form without prior written authorization of Bender Wells Clark Design.

**O. P. Schnabel Bike Park
 Bike Park
 2022 Bond Improvements**
**9700 Rochelle Road
 San Antonio Tx 78240**
The drawing and all design responsibilities are for the site and design and does not apply to any other projects. The reproduction and use of this drawing for other projects is prohibited. Use of this set of drawings requires appropriate authorization from Bender Wells Clark Design.

LANDSCAPE ARCHITECT'S LICENSURE

THESE DOCUMENTS ARE INCOMPLETE AND ARE RELEASED FOR INTERIM REVIEW ONLY, AND NOT INTENDED FOR REGULATORY APPROVAL, BIDDING, PERMIT, OR CONSTRUCTION PURPOSES.

Drawn By :
 SHEET TITLE & NUMBER:
**Site Development
 Plan: East Bike
 Park Area**

SD-1.2

Date: Jan 05, 2024, 2:06pm User ID: lclark
 File: S:\2022 PROJECTS\OP Schnabel Bike Park\Workfile\2024-1-4 OPS SCH DD BASE.dwg



DESIGN
 DEVELOPMENT
 SUBMITTAL
 DOCUMENTS

1 SITE DEVELOPMENT PLAN: WEST AREA
 Scale 1" = 50'-0"



ISSUED SETS	
Date	Description

REVISIONS		
No.	Date	Description

LANDSCAPE ARCHITECT
BENDER WELLS CLARK DESIGN
 830 N. ALAMO ST.
 SAN ANTONIO, TEXAS 78215

Landscape Architecture
Urban Design
Planning

830 North Alamo Street
 San Antonio, Texas 78215
 210-692-9221
 www.bwcdesign.com

© 2024 Bender Wells Clark Design
 All rights reserved. No part of this document may be reproduced or utilized in any form without prior written authorization of Bender Wells Clark Design.

**O. P. Schnabel Bike Park
 Bike Park
 2022 Bond Improvements**

**9700 Rochelle Road
 San Antonio Tx 78240**

The drawings are designed and prepared specifically for this site and shall not apply to any other projects. The reproduction and use of these drawings for other projects is prohibited. Use of this set of drawings requires appropriate authorization from Bender Wells Clark Design.

LANDSCAPE ARCHITECT'S LICENSURE

THESE DOCUMENTS ARE
 INCOMPLETE AND ARE RELEASED
 FOR INTERIM REVIEW ONLY, AND
 NOT INTENDED FOR REGULATORY
 APPROVAL, BIDDING, PERMIT, OR
 CONSTRUCTION PURPOSES.

Drawn By : _____

SHEET TITLE & NUMBER:
**Site Development
 Plan: West Bike
 Park Area**

SD-1.3

Date: Jan 05, 2024, 2:06pm User ID: lclark
 File: S:\2022 PROJECTS\OP Schnabel Bike Park\Workfile\2024-1-4 OPS SCH DD BASE.dwg

1 CONCRETE WALKS & PAVEMENTS

NTS

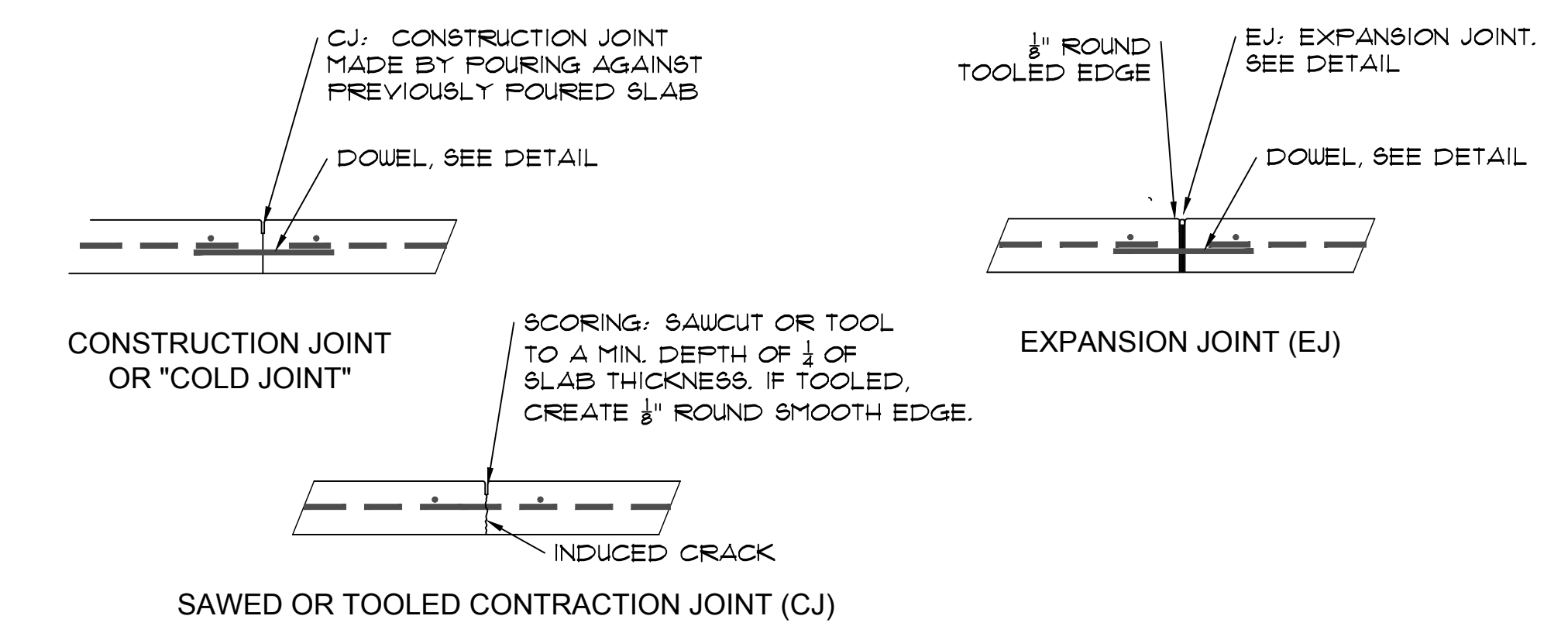
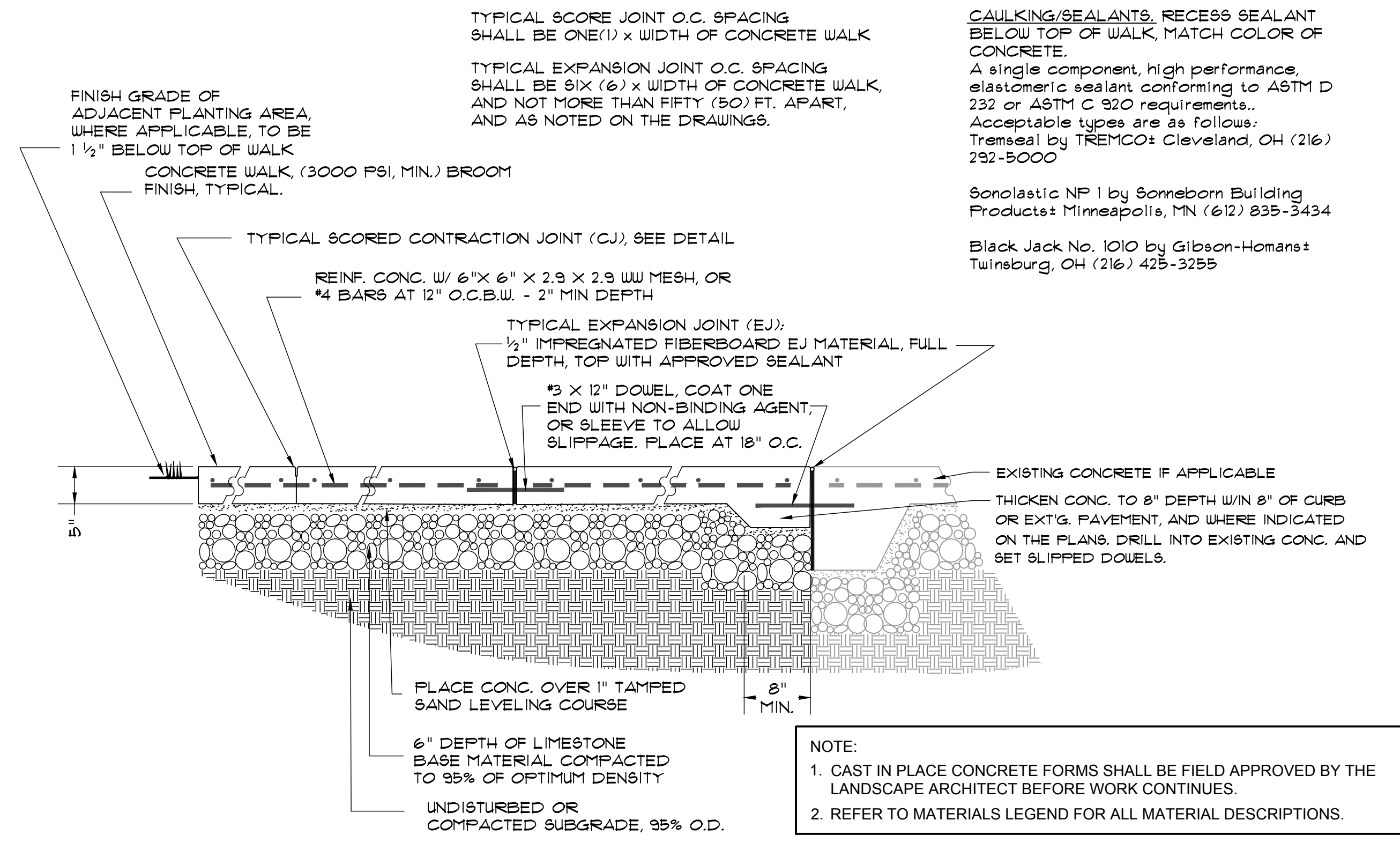

2 CONCRETE JOINTS

NTS

3 CONCRETE DETAIL: CAP AT PAVILION PIERS

NTS

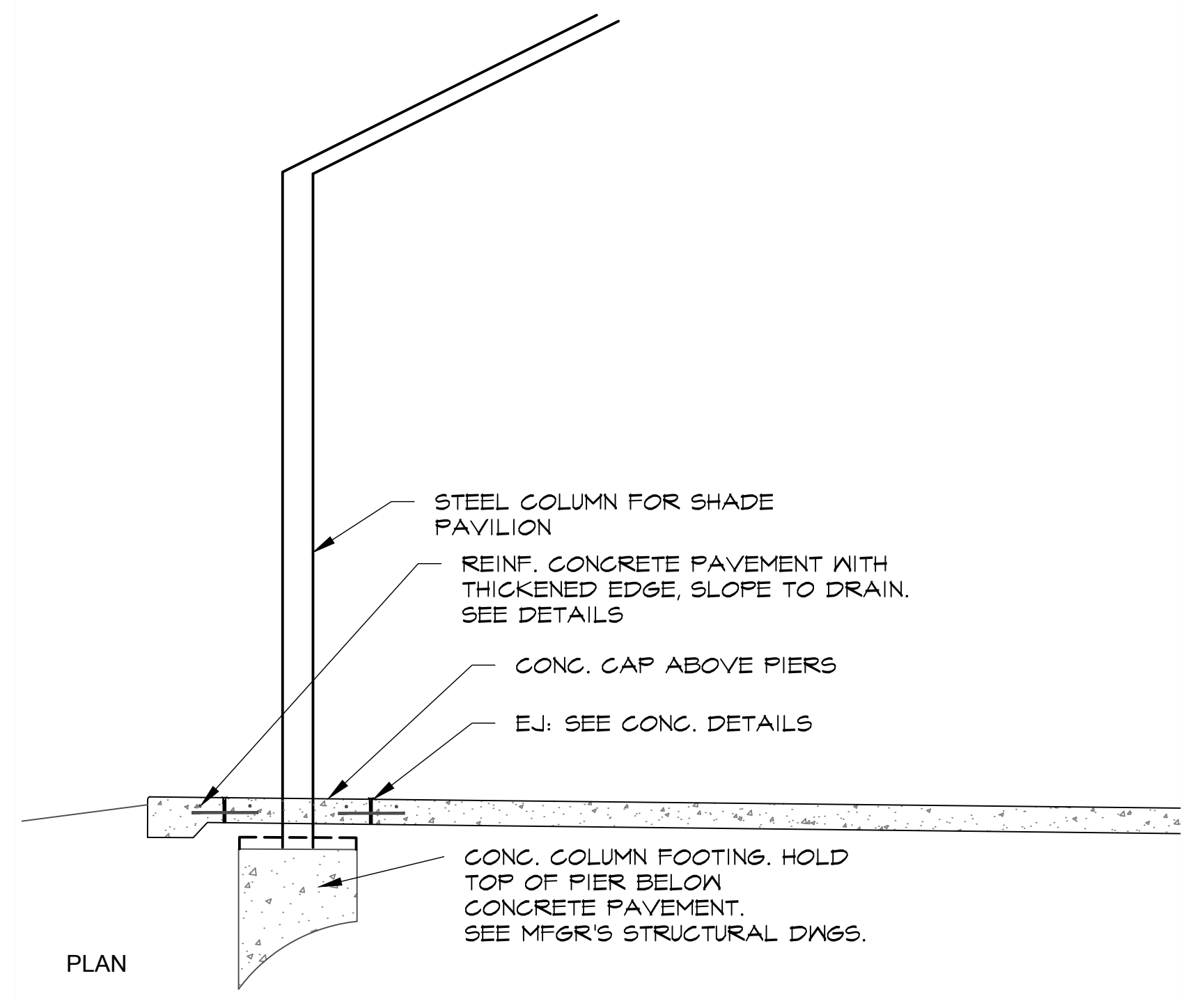

ISSUED SETS	
Date	Description

REVISIONS		
No.	Date	Description

LANDSCAPE ARCHITECT
BENDER WELLS CLARK DESIGN
 830 N. ALAMO ST.
 SAN ANTONIO, TEXAS 78215

Landscape Architecture
Urban Design
Planning

830 North Alamo Street
 San Antonio, Texas 78215
 210-692-9221
 www.bwcdesign.com

© 2024 Bender Wells Clark Design
 All rights reserved. No part of this document may be reproduced or utilized in any form without prior written authorization of Bender Wells Clark Design.

O. P. Schnabel Bike Park
Bike Park
2022 Bond Improvements

9700 Rochelle Road
San Antonio Tx 78240

This drawing and its design or responses are specifically for this site and client and does not apply to any other projects. The reproduction and use of this drawing for any other project is prohibited. Use of this set of drawings requires appropriate authorization from Bender Wells Clark Design.

LANDSCAPE ARCHITECT'S LICENSURE

THESE DOCUMENTS ARE INCOMPLETE AND ARE RELEASED FOR INTERIM REVIEW ONLY, AND NOT INTENDED FOR REGULATORY APPROVAL, BIDDING, PERMIT, OR CONSTRUCTION PURPOSES.

Drawn By :

SHEET TITLE & NUMBER:
Site Development Details

SD-2.0

DESIGN DEVELOPMENT SUBMITTAL DOCUMENTS

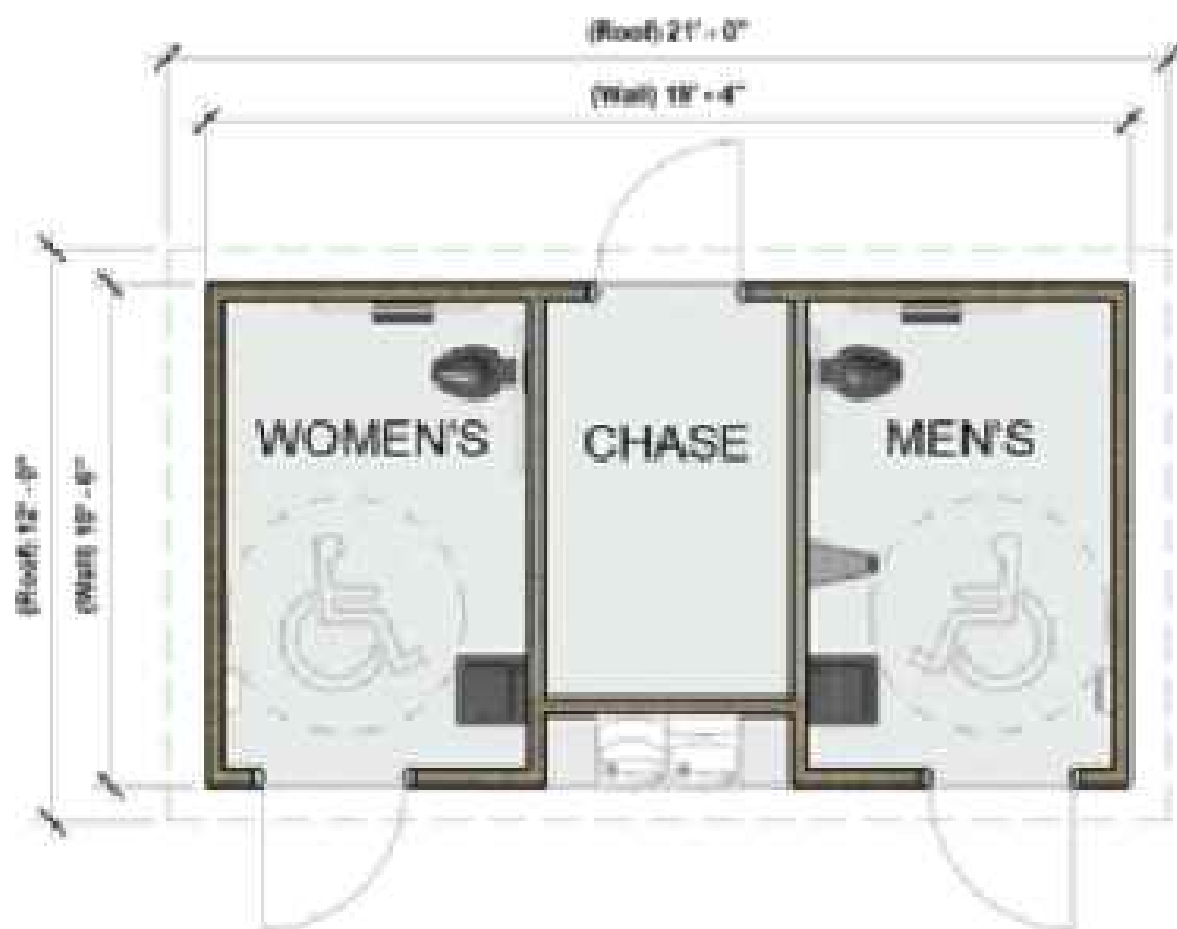

1 FLOOR PLAN



2 FRONT



3 PERSPECTIVE



Building Model : B212DF

1707 COLT CIRCLE
MARBLE FALLS, TEXAS 78654
(512) 222-5454

1 RESTROOM STRUCTURE
Scale 1/4" = 1'-0"

GENERAL NOTE- RESTROOM STRUCTURE:
RESTROOM MANUFACTURER SHALL SUBMIT SHOP DRAWINGS WITH ALL FOOTINGS, REINFORCEMENT, STRUCTURAL ELEMENTS AND ATTACHMENTS DETAILED.
DRAWINGS SHALL BE SIGNED AND SEALED BY A LICENSED PROFESSIONAL ENGINEER WITH CURRENT STATE OF TEXAS LICENSURE AND REGISTRATION.
UPON RECEIPT OF DRAWINGS, PLANS WILL BE SUBMITTED TO THE CITY OF SAN ANTONIO FOR PERMITTING.

ISSUED SETS	
Date	Description

REVISIONS		
No.	Date	Description

LANDSCAPE ARCHITECT
 BENDER WELLS CLARK DESIGN
 830 N. ALAMO ST.
 SAN ANTONIO, TEXAS 78215

Landscape Architecture
Urban Design
Planning

830 North Alamo Street
 San Antonio, Texas 78215
 210-692-9221
 www.bwcdesign.com

© 2024 Bender Wells Clark Design
 All rights reserved. No part of this document may be reproduced or utilized in any form without prior written authorization of Bender Wells Clark Design.

**O. P. Schnabel Bike Park
 Bike Park
 2022 Bond Improvements**

**9700 Rochelle Road
 San Antonio Tx 78240**

This drawing and the design it represents are specifically for this site and shall not apply to any other projects. The reproduction and use of this drawing for other projects is prohibited. Use of this set of drawings requires appropriate authorization from Bender Wells Clark Design.

LANDSCAPE ARCHITECT'S LICENSURE

THESE DOCUMENTS ARE INCOMPLETE AND ARE RELEASED FOR INTERIM REVIEW ONLY, AND NOT INTENDED FOR REGULATORY APPROVAL, BIDDING, PERMIT, OR CONSTRUCTION PURPOSES.

Drawn By :

SHEET TITLE & NUMBER:
**Site Development
 Details**

SD-2.1

DESIGN
 DEVELOPMENT
 SUBMITTAL
 DOCUMENTS

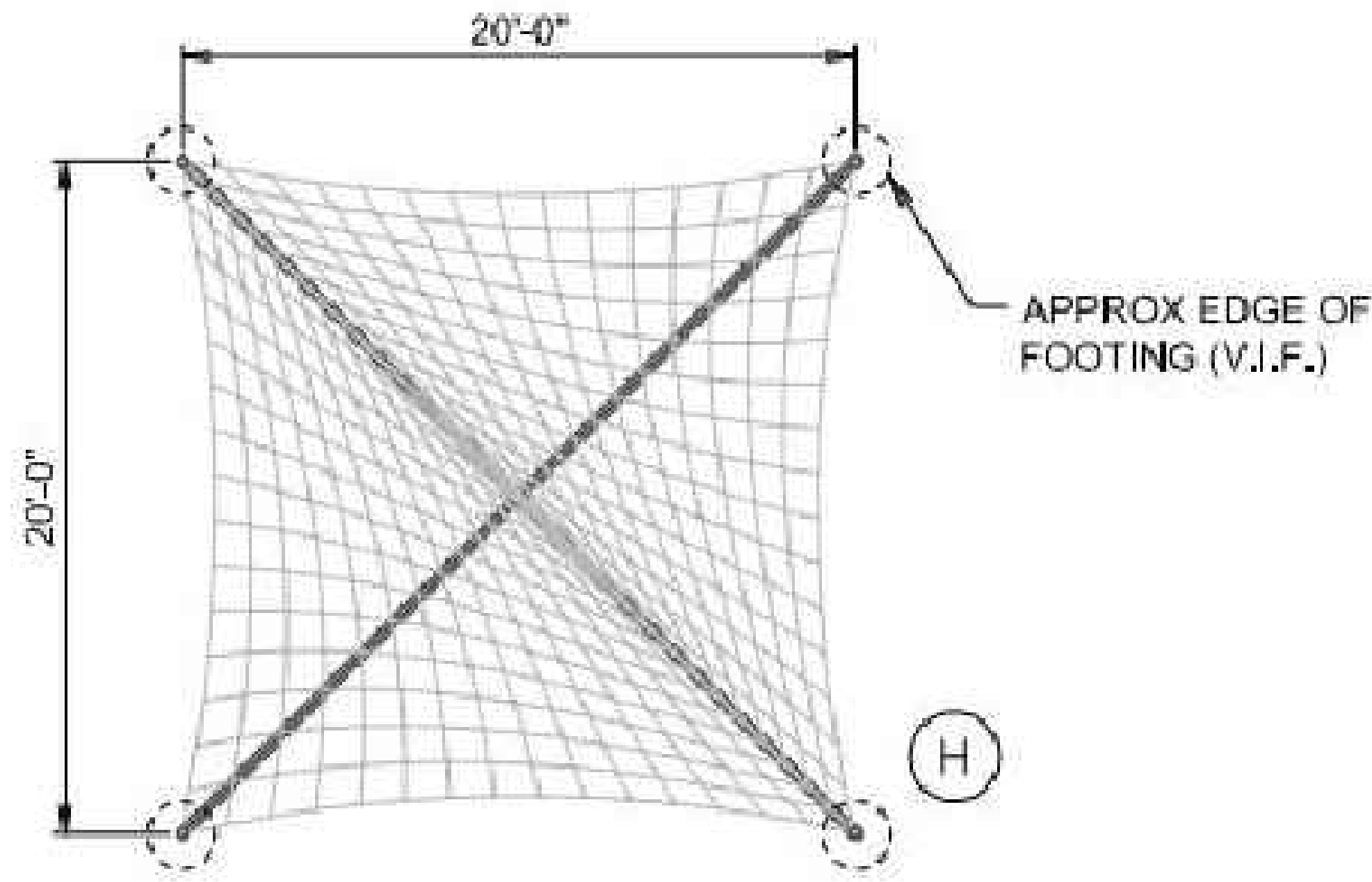

TOP VIEW

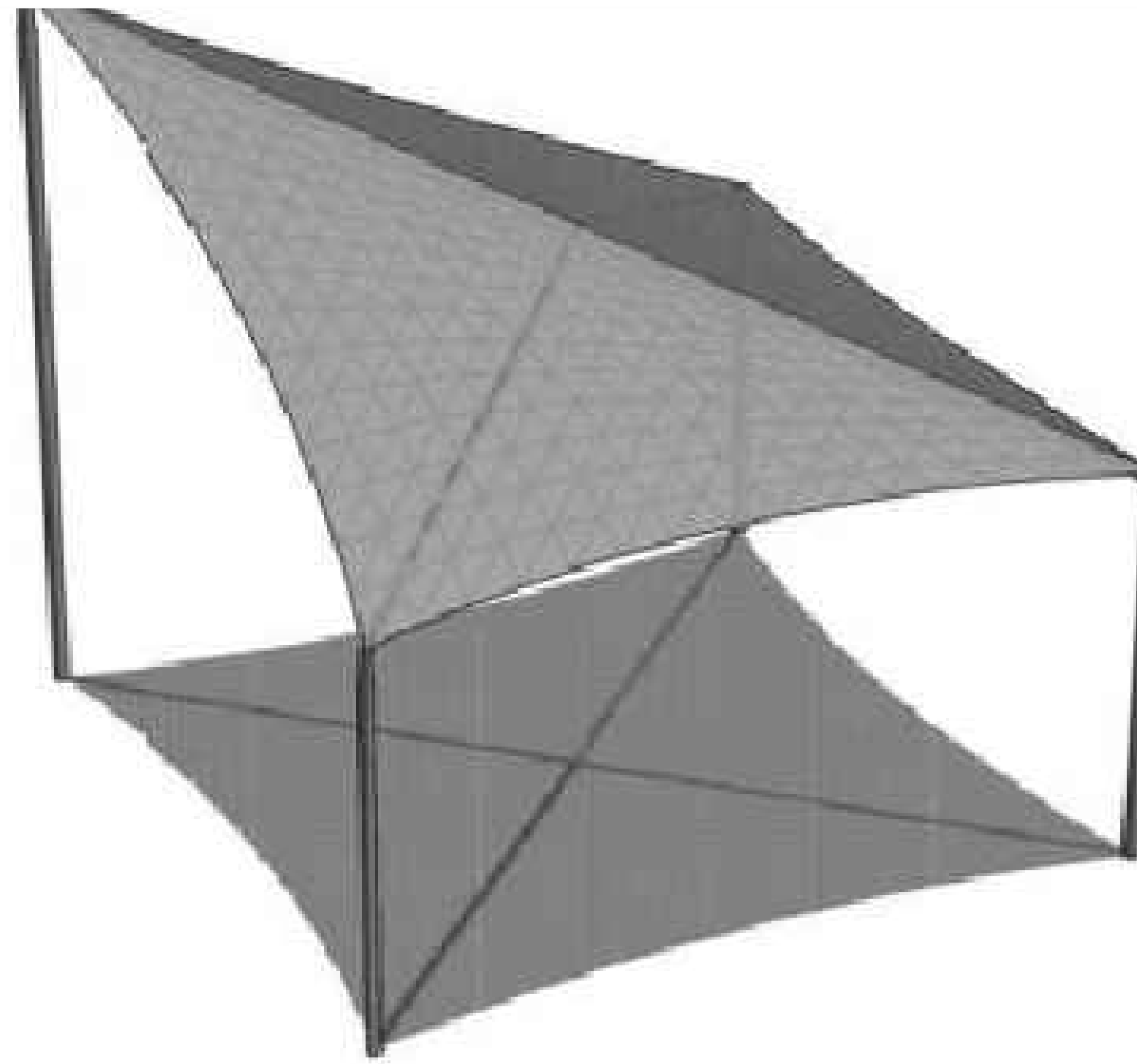

PERSPECTIVE VIEW

**GENERAL NOTE- PAVILION:
PAVILION MANUFACTURER SHALL
SUBMIT SHOP DRAWINGS WITH ALL
FOOTINGS, REINFORCEMENT,
STRUCTURAL ELEMENTS AND
ATTACHMENTS DETAILED. DRAWINGS
SHALL BE SIGNED AND SEALED BY A
LICENSED PROFESSIONAL ENGINEER
WITH CURRENT STATE OF TEXAS
LICENSURE AND REGISTRATION.
UPON RECEIPT OF DRAWINGS, PLANS
WILL BE SUBMITTED TO THE CITY OF
SAN ANTONIO FOR PERMITTING BY
THE MANUFACTURER'S
REPRESENTATIVE AS A "CHILD"
PERMIT (DEFERRED PERMIT).**

1 SHADE STRUCTURE
Scale 1/4" = 1'-0"

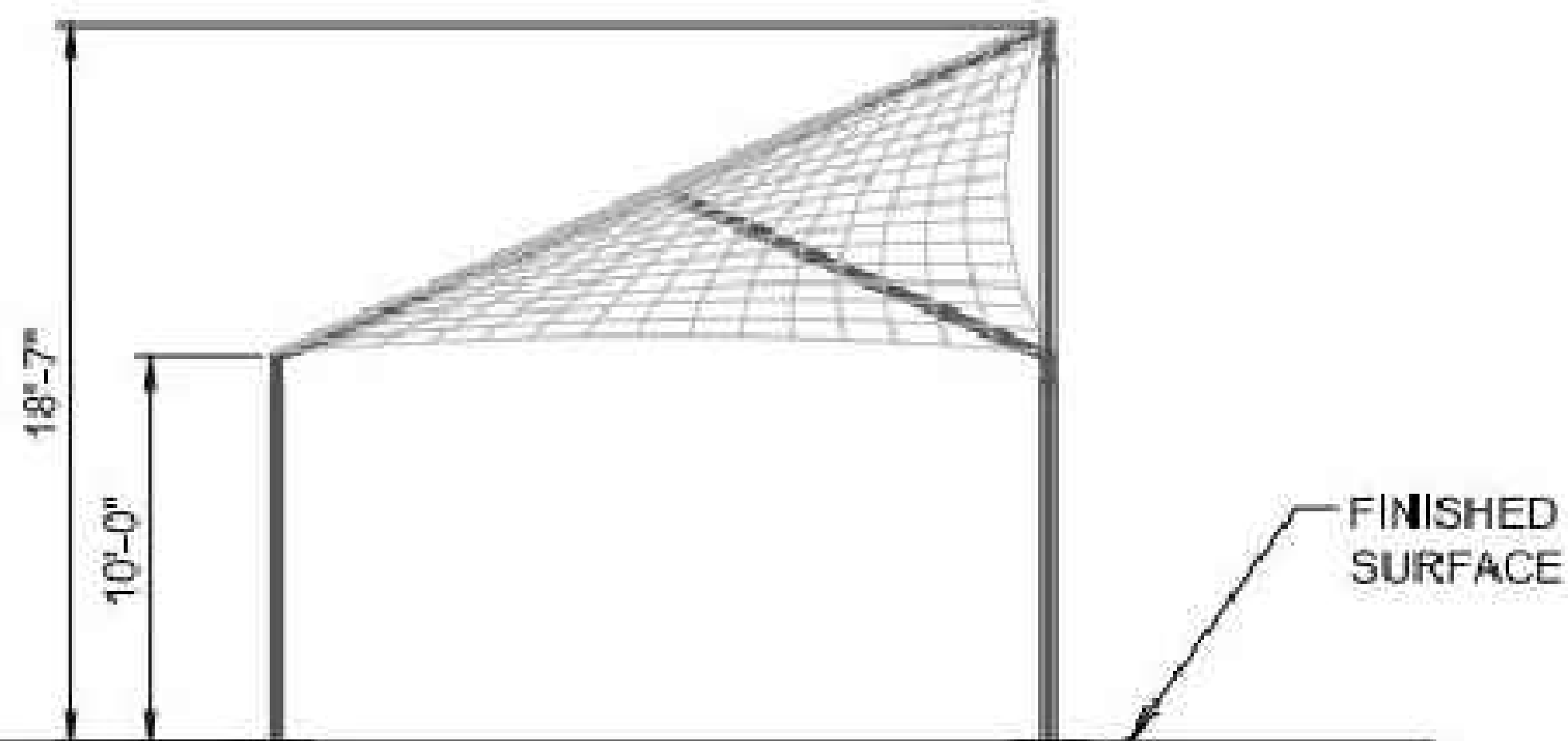

FRONT VIEW

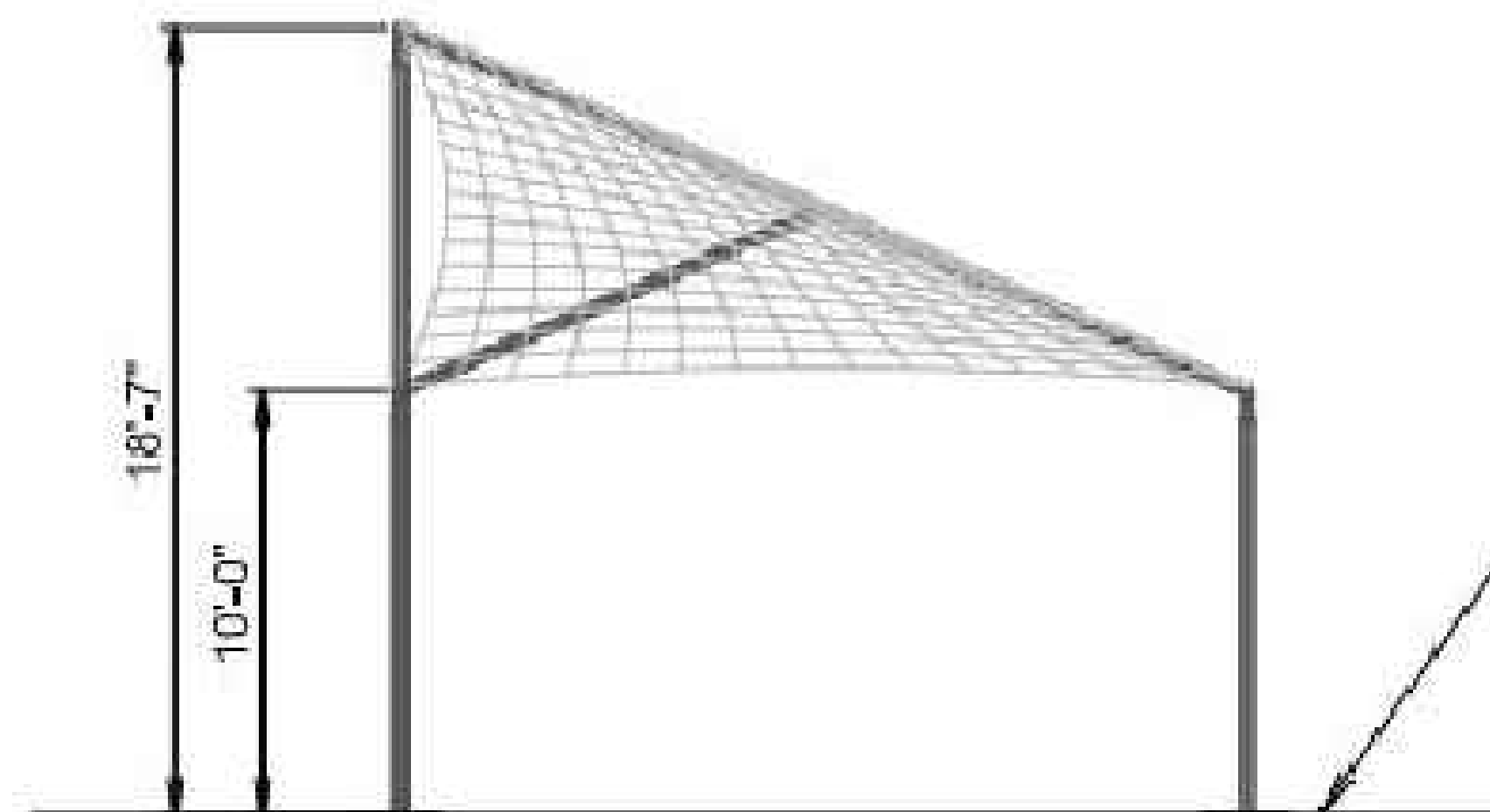

SIDE VIEW

DESIGN
DEVELOPMENT
SUBMITTAL
DOCUMENTS

ISSUED SETS	
Date	Description

REVISIONS		
No.	Date	Description

LANDSCAPE ARCHITECT
BENDER WELLS CLARK DESIGN
830 N. ALAMO ST.
SAN ANTONIO, TEXAS 78215

**LANDSCAPE
Architecture**
Urban Design
Planning

830 North Alamo Street
San Antonio, Texas 78215
210-692-9221
www.bwcdesign.com

© 2024 Bender Wells Clark Design
All rights reserved. No part of this document may be reproduced or utilized in any form without prior written authorization of Bender Wells Clark Design.

**O. P. Schnabel Bike Park
Bike Park
2022 Bond Improvements**

**9700 Rochelle Road
San Antonio Tx 78240**

The drawings and designs are prepared specifically for this site and shall not apply to any other projects. The reproduction and use of these drawings for other projects is prohibited. Use of these drawings requires appropriate authorization from Bender Wells Clark Design.

LANDSCAPE ARCHITECT'S LICENSURE

THESE DOCUMENTS ARE INCOMPLETE AND ARE RELEASED FOR INTERIM REVIEW ONLY, AND NOT INTENDED FOR REGULATORY APPROVAL, BIDDING, PERMIT, OR CONSTRUCTION PURPOSES.

Drawn By :

SHEET TITLE & NUMBER:
**Site Development
Details**

SD-2.2

FLOW TRAILS-DESIGN CRITERIA

THESE GENERAL STRUCTURAL NOTES APPLY TO GENERAL CONTRACTOR UNLESS OTHERWISE NOTED.

CODE:
COMPLY WITH 2015 INTERNATIONAL BUILDING CODE.

SEISMIC:
SEISMIC USE GROUP
SPECTRAL RESPONSE: Sds = 25.2
Sd1 = 10.9
SITE CLASS "D"

WIND:
3-SECOND GUST WIND SPEED 90 M.P.H.
IMPORTANCE FACTOR I = 1.0
WIND EXPOSURE "C"

FLOW TRAILS-STRUCTURAL NOTES

1. SPECIAL STRUCTURAL INSPECTION

1.1 PROVIDE SPECIAL STRUCTURAL INSPECTION AS REQUIRED BY BUILDING CODES FOR THE FOLLOWING ITEMS:

1.1.1 CONCRETE: DURING THE TAKING OF TEST SPECIMENS & PLACING OF REINFORCED CONCRETE WHERE F'c > 2,500 PSI, EXCEPT SLABS ON GRADE.

1.1.2 BOLTS INSTALLED IN CONCRETE: DURING INSTALLATION OF EMBEDDED BOLTS IN CONCRETE AND DURING INSTALLATION OF EXPANSION BOLTS & EPOXY BOLTS / REBAR INTO EXISTING CONCRETE.

1.1.3 REINFORCING STEEL: DURING PLACING OF REINFORCING STEEL, FOR ALL CONCRETE REQUIRED TO HAVE SPECIAL INSPECTION BY THE CONCRETE SECTION ABOVE AND PLACING REINFORCING STEEL IN EPOXIED HOLES PER ABOVE.

1.2 SCHEDULING OF SPECIAL STRUCTURAL INSPECTIONS:

1.2.1 THE CONTRACTOR SHALL ALLOW A MINIMUM OF 72 HOURS NOTIFICATION FOR THE SCHEDULING OF SPECIAL STRUCTURAL INSPECTIONS.

2. FOUNDATIONS

2.1 CONTRACTOR SHALL BE RESPONSIBLE FOR ALL SOILS AND COMPACTION TESTING DURING THE COURSE OF CONSTRUCTION TILL FINAL ACCEPTANCE. A QUALIFIED STRUCTURAL ENGINEER RETAINED Y CONTRACTOR SHALL PROVIDE COMPACTION TESTING PRIOR TO CONCRETE CONSTRUCTION. A RECORD OF SOIL COMPACTION REPORTS SHALL BE SUBMITTED TO THE ADAPTIVE TRACK DESIGNER.

3. REINFORCING

3.1 SECURELY TIE ALL REBAR, INCLUDING DOWELS, IN LOCATION BEFORE PLACING CONCRETE OR GROUT.

3.2 WHERE REINFORCING IS SHOWN CONTINUOUS THRU CONSTRUCTION JOINTS, LENTON FORM SAVERS DOWEL BAR SPLICE DEVICES AS MANUFACTURED BY ERICO PRODUCTS, INC. (ICBO #3967) OR EQUIVALENT SHALL BE USED. SIZES AND TYPES SHALL BE SELECTED TO DEVELOP THE FULL TENSION STRENGTH OF THE BAR PER ICBO RESEARCH REPORT.

4. STRUCTURAL STEEL

4.1 ASTM A-36 FOR C, MC, ANGLES, AND PLATES.

4.2 ASTM A-53 GRADE B OR A-501 FOR STEEL PIPES

4.3 ASTM A-500 GRADE B, Fy=46 KSI FOR TS/HSS TUBE STEEL FOR SIZES UP TO 5/8" THICK.

4.4 ASTM A-307 OR A-36 PLAIN ANCHOR BOLTS.

5. STRUCTURAL STEEL & REINFORCEMENT WELDING

5.1 ALL CONSTRUCTION AND TESTING PER AMERICAN WELDING SOCIETY CODES AND RECOMMENDATIONS. ALL WELDING SHALL BE BY WELDERS HOLDING CURRENT CERTIFICATES VALIDATED BY AN INDEPENDENT LAB & HAVING CURRENT EXPERIENCE IN TYPE OF WELD CALLED FOR. THE CONTRACTOR SHALL SUBMIT WELDING CERTIFICATES FOR EACH WELDER PRIOR TO COMMENCING THE WORK.

5.2 WELDING RODS TO BE LOW HYDROGEN TYPE, E70 SERIES, PER AWS D1.1 TYPICALLY EXCEPT E-6010 SERIES FOR STEEL SHEET METAL PER AWS D1.3 AND REINFORCING WELDMENTS PER AWS D1.4. USE E80 SERIES WELDING RODS FOR A706 REBAR.

5.3 FIELD INDICATED WELDS MAY BE DONE IN SHOP & SHOP INDICATED WELDS MAY BE DONE IN FIELD ONLY IF SUBMITTED AND APPROVED PRIOR TO CONSTRUCTION.

6. SUPPLEMENTARY NOTES

6.1 THESE CONTRACT DOCUMENTS AND SPECIFICATIONS REPRESENT THE FINISHED STRUCTURE. THEY DO NOT INDICATE THE METHOD OF CONSTRUCTION NOR DO THEY INDICATE THE STRUCTURAL CALCULATIONS OR PLANS. THE CONTRACTOR SHALL PROVIDE ALL MEASURES NECESSARY TO PROTECT THE STRUCTURE, WORKERS, AND OTHER PERSONS DURING CONSTRUCTION. SUCH MEASURES SHALL INCLUDE, BUT NOT BE LIMITED TO, MEANS AND METHODS, BRACING, SHORING, FORMS, SCAFFOLDING, GUYING OR OTHER MEANS TO AVOID EXCESSIVE STRESSES AND TO HOLD STRUCTURAL ELEMENTS IN PLACE DURING CONSTRUCTION. OBSERVATION VISITS TO THE SITE BY THE CITY ENGINEER OBSERVERS SHALL NOT INCLUDE INSPECTION OF THE ABOVE ITEMS.

6.2 REINFORCING OR THREADED RODS DRILLED AND EPOXIED INTO EXISTING CONCRETE AS DETAILED ON THE DRAWINGS SHALL BE ONE OF THE FOLLOWING OR APPROVED EQUIVALENT:

6.2.1 HILTI RE-500 SD - ICC ESR-2322

6.2.2 SIMPSON SET-XP - ICC ESR-2508

6.2.3 POWERS PE1000+ - ICC ESR-2583

6.3 INSTALLATION OF EPOXIED DOWELS SHALL FOLLOW THE STRICT RECOMMENDATIONS OF THE MANUFACTURER AND THE APPLICABLE ICBO REPORT AND HAVE A MINIMUM 9 DIAMETERS EMBEDMENT.

6.4 ANY ENGINEERING AND/ OR STRUCTURAL DESIGN PROVIDED BY CONTRACTOR AND SUBMITTED FOR REVIEW SHALL BE BY AN INSURED LICENSED STRUCTURAL ENGINEER WITH CONTINUOUS FIVE YEARS OF EXPERIENCE IN THE TYPE OF DESIGN SUBMITTED.

FLOW TRAILS GENERAL NOTES

1. GENERAL

1.1 CONSIDER GENERAL NOTES AS APPLYING TO ALL DRAWINGS.

1.2 NOTIFY THE LANDSCAPE ARCHITECT/ ENGINEER OF ANY DISCREPANCIES TO THESE PLANS.

1.3 PERFORM ALL WORK IN ACCORDANCE WITH ALL APPLICABLE NATIONAL, STATE AND/OR LOCAL BUILDING CODES.

1.4 THE LANDSCAPE ARCHITECT/ ENGINEER SHALL HAVE NO CONTROL OR CHARGE OF, NOR BE RESPONSIBLE FOR THE CONSTRUCTION MEANS, METHODS, TECHNIQUES, SEQUENCES, OR PROCEDURES, SAFETY PRECAUTIONS, AND PROGRAMS IN CONNECTION WITH THE WORK. THE ACTS OR OMISSIONS OF THE CONTRACTOR, SUBCONTRACTOR, OR ANY PERSONS PERFORMING ANY OF THE WORK OR FOR THE FAILURE OF ANY OF THEM TO CARRY OUT THE WORK IN CONFORMANCE WITH THE CONTRACT DOCUMENTS.

1.5 PROVIDE SPECIAL INSPECTION AS REQUIRED BY BUILDING CODES FOR THE FOLLOWING ITEMS:

1.5.1 PLACEMENT OF REINFORCING STEEL.

1.5.2 TAKING OF TEST SPECIMENS AND PLACING OF ALL CONCRETE.

1.5.3 BOLTS IN CONCRETE.

1.5.4 TAKING OF TEST SPECIMENS AND PLACING OF ALL CONCRETE.

1.5.5 TAKING OF TEST SPECIMENS AS SPECIFIED BY THE STRUCTURAL PLANS (BY CONTRACTOR).

1.6 THE CONTRACTOR SHALL WARRANTY ALL OF THEIR WORK DURING CONSTRUCTION AND A MINIMUM OF THREE YEARS AFTER THE PROJECT IS ACCEPTED AS COMPLETE.

1.7 THE METRIC EQUIVALENT [] DIMENSIONS ARE SHOWN FOR REFERENCE ONLY. THE CONTRACTOR SHALL BE RESPONSIBLE TO VERIFY THEIR ACCURACY.

2. CONCRETE WORK

2.1 CONCRETE MIXES SHALL BE DESIGNED BY A TESTING LABORATORY AND APPROVED BY THE LANDSCAPE ARCHITECT/ ENGINEER. MIXES SHALL CONFORM TO APPLICABLE BUILDING CODE REQUIREMENTS, REGARDLESS OF OTHER MINIMUM REQUIREMENTS SPECIFIED HEREIN OR ON THE DRAWINGS. MIX DESIGNS SHALL BE SUBMITTED TO THE LANDSCAPE ARCHITECT/ ENGINEER FOR APPROVAL BEFORE USE. DESIGNS SHALL SHOW PROPORTIONS OF CEMENT, FINE AND COARSE AGGREGATES AND WATER, AND GRADATION OF COMBINED AGGREGATES.

2.2 CEMENT: ASTM C150. CEMENT SHALL BE OF SAME BRAND, TYPE AND SOURCE THROUGHOUT PROJECT. WHERE AGGREGATES ARE POTENTIALLY REACTIVE, USE LOW ALKALI CEMENT.

2.3 AGGREGATES/ SELECT FILL SHALL CONFORM TO STRUCTURAL DRAWINGS/ CALCULATIONS (BY CONTRACTOR).

2.4 NO ADMIXTURES WITHOUT APPROVAL. ADMIXTURES CONTAINING CHLORIDES SHALL NOT BE USED. CONCRETE SHALL NOT BE IN CONTACT WITH ALUMINUM.

2.5 CONCRETE MIX DESIGN - CAST-IN-PLACE

2.5.1 PROVIDE MIX DESIGNS THAT WILL MEET THE MINIMUM REQUIREMENTS LISTED BELOW. INCREASE CEMENT CONTENT OVER THAT SHOWN, IF REQUIRED TO OBTAIN THE COMPRESSIVE STRENGTH:

MIN. 28-DAY COMPRESSIVE STRENGTH (PSI)	MIN. CEMENT CONTENT (POUNDS)	MAX. SLUMP (INCHES)	MAX. AGGREGATE SIZE (INCHES)	MAX. AIR ENTRAINING (PERCENT)
4000	480	4"	1"	3-5%

2.6 CONCRETE SHALL BE PLACED WITHIN 90 MINUTES OF BATCHING AND SHALL NOT EXCEED A TEMPERATURE OF 90°F UNLESS PRE-APPROVED BY THE LANDSCAPE ARCHITECT/ ENGINEER.

2.7 CONCRETE CYLINDERS SHALL BE TAKEN AND TESTED PER THE CODE BY AN INDEPENDENT TESTING LABORATORY FOR STRUCTURAL POURS OVER 50 CUBIC YARDS OF CONCRETE. HISTORICAL DATA SHALL BE SUBMITTED AND APPROVED PRIOR TO THE POUR IF NO TEST SAMPLES ARE TAKEN FOR POURS LESS THAN 50 CUBIC YARDS.

2.8 CONCRETE SHALL BE MAINTAINED AT A TEMPERATURE ABOVE 40°F AND IN MOIST CONDITION. FOR INITIAL CURING, CONCRETE SHALL BE KEPT CONTINUOUSLY MOIST FOR 24 HOURS AFTER PLACEMENT IS COMPLETE. FINAL CURING SHALL CONTINUE FOR SEVEN DAYS AFTER PLACEMENT AND SHALL CONSIST OF APPLICATION OF CURING COMPOUND PER ASTM C309. APPLY AT A RATE SUFFICIENT TO RETAIN MOISTURE, BUT NOT LESS THAN 1 GALLON (4.55) PER 200 SQUARE FEET. COVER CONCRETE WITH POLYETHYLENE PLASTIC TO MAINTAIN TEMPERATURE IF NECESSARY. LAP SEAMS IN THE PLASTIC 6" AND TAPE. WEIGHT DOWN THE PLASTIC AS NEEDED.

2.9 THE CONTRACTOR SHALL FIX ALL CRACKS AND DISPLACEMENTS LARGER THAN 1/16".

2.11 ALL CONCRETE WHICH DURING THE LIFE OF THE STRUCTURE WILL BE SUBJECTED TO FREEZING TEMPERATURES WHILE WET, SHALL HAVE A WATER CEMENT RATIO NOT EXCEEDING 0.53 BY WEIGHT AND SHALL CONTAIN ENTRAINED AIR AS PER ACI 301. SUCH CONCRETE SHALL INCLUDE EXTERIOR SLABS, PERIMETER FOUNDATIONS, EXTERIOR CURBS AND GUTTERS, ETC.

2.12 CONDUITS, PIPES, AND SLEEVES EMBEDDED IN CONCRETE SHALL CONFORM TO THE REQUIREMENTS OF IBC SECTION 1906.

2.13 USE INTERMEDIATE GRADE ASTM A615, GRADE 60 FOR ALL REINFORCING. USE ASTM A706, GRADE 60 FOR ALL REINFORCING THAT IS TO BE WELDED. USE A108, GRADE 60, FOR ALL WELDED ANCHORS REFER TO AWS SPEC FOR WELDING WITHOUT PREHEAT. WELDING OF REINFORCING BARS TO BE IN ACCORDANCE WITH ALL BUILDING CODES.

2.14 OBSERVE FOLLOWING REINFORCEMENT CLEARANCES:
3" AT SURFACES POURED AGAINST EARTH
2" AT FORMED SURFACES EXPOSED TO EARTH OR WEATHER
1-1/2" AT OTHER SURFACES, EXCEPT WHERE SHOWN OTHERWISE.

2.15 SECURE REINFORCING, ANCHOR BOLTS, INSERTS, ETC. RIGIDLY IN PLACE PRIOR TO POURING CONCRETE.

2.16 SUPPORT HORIZONTAL REINFORCING ON GALVANIZED CHAIRS OR OTHER APPROVED METHOD OF SUPPORT FOR FOOTINGS AND SLABS ON GRADE (MORTAR BLOCKS ARE UNACCEPTABLE).

2.17 REMOVE FORMS AT FOLLOWING MINIMUM TIMES AFTER POURING: AT SLAB EDGES - 24 HOURS. REFER TO GENERAL ACI REQUIREMENTS.

2.18 MAKE HOOKS ACI 318-99 STANDARD HOOKS UNLESS OTHERWISE NOTED. PROVIDE 135 DEGREE MINIMUM TURN, PLUS 4" EXTENSION AT FREE ENDS OF COLUMN PILASTER TIES.

2.19 MAKE LAPS CONTACT SPLICES, DEVELOPMENT LENGTHS, HOOK EMBEDMENT PER ACI 318-99, UNLESS OTHERWISE NOTED. STAGGER LAP SPLICES WHERE POSSIBLE.

2.20 ALL REBAR SHALL BE COLD BENT.

2.21 WHERE REINFORCING IS SHOWN CONTINUOUS THRU CONSTRUCTION JOINTS, LENTON FORM SAVERS DOWEL BAR SPLICE DEVICES AS MANUFACTURED BY ERICO PRODUCTS, INC. (ICBO #3967) OR EQUIVALENT SHALL BE USED. SIZES AND TYPES SHALL BE SELECTED TO DEVELOP THE FULL TENSION STRENGTH OF THE BAR PER ICBO RESEARCH REPORT.

2.22 MINIMUM CLEARANCE BETWEEN PARALLEL REINFORCEMENT BARS SHALL BE 2-1/2". LAP SPLICES IN REINFORCING BARS SHALL BE BY THE NON-CONTRACT LAP SPLICE METHOD WITH AT LEAST 2" CLEARANCE BETWEEN BARS.

2.23 SELECT FILL/ ENGINEERED FILL TO BE SPECIFIED BY STRUCTURAL ENGINEER, RETAINED BY CONTRACTOR, AND SHALL HAVE 95% COMPACTED NATIVE SOIL AND/ OR SELECT FILL/ ENGINEERED FILL. IF THESE GUIDELINES CONFLICT WITH THE GEO-TECHNICAL REPORT AND/ OR STRUCTURAL ENGINEERS PLANS/ SPECIFICATIONS, THE CONTRACTOR TO FOLLOW THE MORE STRINGENT OF THE TWO GUIDELINES.

FLOW TRAILS- SITE AND GENERAL NOTES

1. THE CONTRACTOR SHALL BE RESPONSIBLE FOR SETTING ALL GRADES, LINES, AND MEASUREMENTS NECESSARY TO THE PROPER PERFORMANCE AND CONTROL OF THE WORK.
2. THE CONTRACTOR SHALL BE RESPONSIBLE FOR FILLING OR CUTTING AS NECESSARY TO ENSURE THAT ALL PORTIONS OF THE SITE DRAIN.
3. THE CONTRACTOR SHALL VERIFY ALL EXISTING GRADES AND SITE CONDITIONS BY FIELD INSPECTION BEFORE SUBMITTING A BID.
4. ALL OBJECTIONABLE MATERIALS DISCOVERED IN THE SOIL DURING THE GRADING PROCESS SHALL BE REMOVED FROM THE SITE BY CONTRACTOR.
5. ANY DAMAGE TO THE EXISTING STREET PAVING, CURBS OR OTHER EXISTING ELEMENTS SHALL BE REPAIRED AT THE CONTRACTOR'S EXPENSE.
6. THE CONTRACTOR SHALL BE RESPONSIBLE FOR SHOOTING ALL SPOT ELEVATIONS NECESSARY TO CONSTRUCT THE PROJECT.
7. CONTRACTOR SHALL DETERMINE THE AMOUNT OF CUT AND FILL NECESSARY TO COMPLETE THE EARTHWORK AS SHOWN ON THESE PLANS AND INCLUDE A FEE FOR COMPLETION OF THE EARTHWORK IN THE BASE BID.
8. SOIL SHALL NOT CONTAIN ROCKS 6" OR LARGER IN ANY DIMENSION. THE FINISH GRADE (TOP 6" OF DEPTH) SHALL NOT CONTAIN ANY ROCKS LARGER THAN ONE-HALF (1/2") IN DIAMETER.
9. HORIZONTAL CONTROL POINTS ARE FOR POSITIONING POINTS AND DIMENSION CLARIFICATION ONLY.
10. TREES SHALL NOT BE REMOVED WITHOUT THE SPECIFIC CONSENT OF THE OWNER'S PROJECT REPRESENTATIVE. THE CONTRACTOR WILL BE RESPONSIBLE FOR REPLACING TREES REMOVED WITHOUT RECEIVING PROPER APPROVAL.
11. THE CONTRACTOR IS RESPONSIBLE FOR THE PROTECTION OF TREE'S, SHRUBS AND OTHER PLAN MATERIAL WITHIN THE LIMITS OF THE WORK TO REMAIN. ANY PLANTING MATERIAL DAMAGED TO AND FROM PROJECT SITE PATH WILL BE AT THE EXPENSE OF CONTRACTOR WITH "AS-EQUAL" MATERIAL.
12. CONTRACTOR IS RESPONSIBLE FOR ACQUIRING AND PAYING ALL PERMITS AND INSPECTIONS FROM ALL JURISDICTIONAL AGENCIES AND CORPORATIONS. THE CONTRACTOR WILL BE REQUIRED TO PAY ALL PERMIT FEE'S UNLESS OTHERWISE NOTED.
13. THE CONTRACTOR SHALL RESTORE ALL AREAS DISTURBED BY CONSTRUCTION TO ORIGINAL CONDITION OR BETTER. RESTORED AREAS INCLUDE, BUT ARE NOT LIMITED TO TRENCH BACKFILL, SIDE SLOPES, FENCES, DRAIN PIPES, DRAINAGE DITCHES, DRIVEWAYS, LANDSCAPING, EXISTING GRADE ELEVATIONS.
14. THE GENERAL CONTRACTOR IS RESPONSIBLE FOR PLACEMENT OF ALL SLEEVES UNDER CONCRETE PAVING AS INDICATED ON THE PLANS.
15. ADEQUATE MEASURES SHALL BE TAKEN TO PREVENT EROSION. IN THE EVENT THAT SIGNIFICANT EROSION OCCURS AS A RESULT OF CONSTRUCTION, THE CONTRACTOR SHALL RESTORE THE ERODED AREA TO ORIGINAL CONDITION.
16. DISCREPANCIES IF ANY, SHOULD BE BROUGHT TO THE ATTENTION OF THE ADAPTIVE TRACK DESIGNER BEFORE WORK COMMENCES.
17. ALL CONSTRUCTION SHALL CONFORM TO ALL APPLICABLE CODES AND ORDINANCES (FEDERAL, STATE, LOCAL, AND HEALTH DEPARTMENTS), EXCEPT WHERE REQUIREMENTS OF CONTRACT DOCUMENTS ARE MORE STRINGENT.
18. NO DESIGN MODIFICATIONS SHALL BE MADE WITHOUT THE OWNER'S AND/ OR ADAPTIVE TRACK DESIGNER APPROVAL.

FLOW TRAILS- SITE- GRADING & DRAINAGE

1. FINAL HEIGHT AND SHAPE OF EXCAVATION TO BE VERIFIED BY BMX TRACK DESIGNER IN THE FIELD.
2. ALL SPOT ELEVATIONS ARE FOR TOP OF FINISH WORK UNLESS OTHERWISE NOTED.
3. MINIMUM SLOPE FOR ALL CONCRETE FINISH WORK SHALL BE 1%. WATER MUST DRAIN TOWARDS DIRECTION OF FLOW ARROWS AND FOLLOW OVERALL DESIGN INTENT.
4. ALL AREAS DISTURBED BY GRADING OPERATIONS TO BE FINE GRADED.
5. VERIFY LOCATION AND DEPTH OF ALL UTILITIES PRIOR TO COMMENCING WORK.
6. REFER TO SECTIONS, DETAILS AND PROFILES FOR HEIGHT, RADII AND PROFILES.
7. ALL FINE GRADING OF EARTHWORK SHALL BE INSPECTED WITH TEMPLATES CUT TO THE SPECIFIED RADII/ ANGLE. CONTRACTOR TO PROVIDE SHOP DRAWINGS FOR ALL TEMPLATES/ SCREEDS TO BE USED FOR EARTHWORK TOLERANCES FOR APPROVAL BY ADAPTIVE TRACK DESIGNER.
8. CONTRACTOR TO PROTECT ALL EXCAVATIONS FROM SOIL EROSION AND WATER SATURATION AT ALL TIMES USING APPROPRIATE CONSTRUCTION METHODS. LOSS OF SOIL PROFILE DURING CONSTRUCTION SHALL BE REPLACED WITH APPROPRIATE SOIL COMPOSITION AND COMPACTION METHODS TO MATCH LOSS SOIL.

FLOW TRAILS- SITE- SURVEY NOTES

1. LOCATE ALL SURVEY MARKS INCLUDING BENCH MARKS AND PROPERTY LINES IN ORDER THAT THE EXACT LINES OF CONSTRUCTION LIMITS AND GRADES MAY BE DETERMINED. BRING ANY DISCREPANCIES TO THE OWNER'S REPRESENTATIVE IMMEDIATELY BEFORE PROCEEDING WITH WORK.
2. VERIFY ENTIRE LAYOUT PRIOR TO START OF CONSTRUCTION WITH PROJECT OWNER'S REPRESENTATIVES AND ADAPTIVE TRACK DESIGNER.
3. LOCATE AND PROTECT CONTROL POINTS PRIOR TO STARTING SITE WORK AND PROTECT ALL PERMANENT REFERENCE POINTS DURING ENTIRE CONSTRUCTION. REPLACE PROJECT CONTROL POINTS WHICH MAY BE LOST OR DESTROYED DURING CONSTRUCTION.

EXISTING CONDITIONS & DEMOLITION

1. ALL MATERIAL "TO REMAIN" SHALL BE PROTECTED DURING CONSTRUCTION.
2. ALL MATERIALS "TO BE REMOVED" SHALL BE TAKEN FROM THE SITE AND DISPOSED OF PROPERLY.
3. IT IS THE CONTRACTOR'S RESPONSIBILITY TO INSPECT THE JOB SITE TO BECOME FAMILIAR WITH ALL EXISTING CONDITIONS THAT COULD AFFECT THE INSTALLATION OF ANY WORK SET FORTH IN THESE PLANS PRIOR TO SUBMITTING A BID.
4. THE CONTRACTOR SHALL BE RESPONSIBLE FOR VERIFYING THE EXISTENCE AND LOCATION OF ANY UTILITIES THAT MAY BE NEEDED OR AVOIDED IN THE DEMOLITION PHASE IN ADVANCE OF ANY CONSTRUCTION. ASD DOES NOT GUARANTEE ANY LOCATIONS REFERENCED.
5. THE CONTRACTOR SHALL CONTACT ALL UTILITY ENTITIES AND OWNER FOR EXISTING LOCATIONS PRIOR TO ANY CONSTRUCTION ACTIVITY.
6. THE CONTRACTOR SHALL PROVIDE TRAFFIC CONTROL AS NECESSARY DURING CONSTRUCTION.
7. THE CONTRACTOR SHALL OBTAIN ALL NECESSARY PERMITS PRIOR TO CONSTRUCTION.

ISSUED SETS		
Date	Description	
01/05/2024	DD SUBMITTAL For Review Only	
REVISIONS		
No.	Date	Description

LANDSCAPE ARCHITECT
BENDER WELLS CLARK DESIGN
830 N. ALAMO ST.
SAN ANTONIO, TEXAS 78215

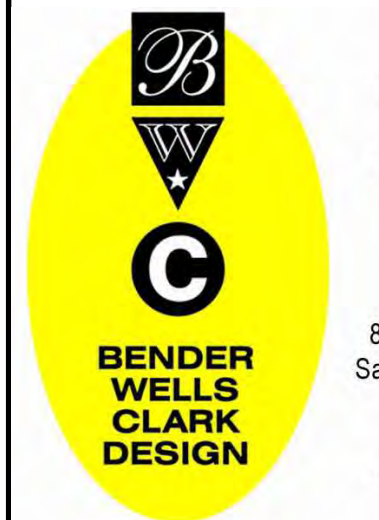

Landscape Architecture

Urban Design

Planning

830 North Alamo Street
San Antonio, Texas 78215

210-692-9221
www.bwcdesign.com

© 2023 Bender Wells Clark Design
All rights reserved. No part of this document may be reproduced or utilized in any form without prior written authorization of Bender Wells Clark Design.

O. P. Schnabel Bike Park
Bike Park
2022 Bond Improvements

9700 Rochelle Road
San Antonio Tx 78240

This drawing and the design was prepared specifically for this site and client and does not apply to any other projects. The reuse of this design for any other project is prohibited. Use of this site for drawings requires appropriate authorization from Bender Wells Clark Design.

LANDSCAPE ARCHITECT'S LICENSE

THESE DOCUMENTS ARE INCOMPLETE AND ARE RELEASED FOR INTERIM REVIEW ONLY, AND NOT INTENDED FOR REGULATORY APPROVAL, BIDDING, PERMIT, OR CONSTRUCTION PURPOSES.

Drawn By : MM/ MJ Checked By : MM

SHEET TITLE & NUMBER:

BIKE PARK
FLOW TRAIL NOTES

BP-01.02

Date: Jan 05, 2024, 2:39pm User ID: Mitch
 File: C:\Users\Mitch\actionsportsdesign.com\PROJECTS - Documents\TX-San Antonio-OP Schnabel Bike Park-23-050-BP-04-Construction Documents\Sheet Files\BP-NOTES.dwg

FLOW TRAILS-GENERAL CONSTRUCTION NOTES - CONT'D

FLOW TRAILS- SITE AND GENERAL NOTES

1. THE CONTRACTOR SHALL BE RESPONSIBLE FOR SETTING ALL GRADES, LINES, AND MEASUREMENTS NECESSARY TO THE PROPER PERFORMANCE AND CONTROL OF THE WORK.
2. THE CONTRACTOR SHALL BE RESPONSIBLE FOR FILLING OR CUTTING AS NECESSARY TO ENSURE THAT ALL PORTIONS OF THE SITE DRAIN.
3. THE CONTRACTOR SHALL VERIFY ALL EXISTING GRADES AND SITE CONDITIONS BY FIELD INSPECTION BEFORE SUBMITTING A BID.
4. ALL OBJECTIONABLE MATERIALS DISCOVERED IN THE SOIL DURING THE GRADING PROCESS SHALL BE REMOVED FROM THE SITE BY CONTRACTOR.
5. ANY DAMAGE TO THE EXISTING STREET PAVING, CURBS OR OTHER EXISTING ELEMENTS SHALL BE REPAIRED AT THE CONTRACTOR'S EXPENSE.
6. THE CONTRACTOR SHALL BE RESPONSIBLE FOR SHOOTING ALL SPOT ELEVATIONS NECESSARY TO CONSTRUCT THE PROJECT.
7. CONTRACTOR SHALL DETERMINE THE AMOUNT OF CUT AND FILL NECESSARY TO COMPLETE THE EARTHWORK AS SHOWN ON THESE PLANS AND INCLUDE A FEE FOR COMPLETION OF THE EARTHWORK IN THE BASE BID.
8. SOIL SHALL NOT CONTAIN ROCKS 6" OR LARGER IN ANY DIMENSION. THE FINISH GRADE (TOP 6" OF DEPTH) SHALL NOT CONTAIN ANY ROCKS LARGER THAN ONE-HALF (1/2") IN DIAMETER.
9. HORIZONTAL CONTROL POINTS ARE FOR POSITIONING POINTS AND DIMENSION CLARIFICATION ONLY.
10. TREES SHALL NOT BE REMOVED WITHOUT THE SPECIFIC CONSENT OF THE OWNER'S PROJECT REPRESENTATIVE. THE CONTRACTOR WILL BE RESPONSIBLE FOR REPLACING TREES REMOVED WITHOUT RECEIVING PROPER APPROVAL.
11. THE CONTRACTOR IS RESPONSIBLE FOR THE PROTECTION OF TREE'S, SHRUBS AND OTHER PLAN MATERIAL WITHIN THE LIMITS OF THE WORK TO REMAIN. ANY PLANTING MATERIAL DAMAGED TO AND FROM PROJECT SITE PATH WILL BE AT THE EXPENSE OF CONTRACTOR WITH 'AS-EQUAL' MATERIAL.
12. CONTRACTOR IS RESPONSIBLE FOR ACQUIRING AND PAYING ALL PERMITS AND INSPECTIONS FROM ALL JURISDICTIONAL AGENCIES AND CORPORATIONS. THE CONTRACTOR WILL BE REQUIRED TO PAY ALL PERMIT FEE'S UNLESS OTHERWISE NOTED.
13. THE CONTRACTOR SHALL RESTORE ALL AREAS DISTURBED BY CONSTRUCTION TO ORIGINAL CONDITION OR BETTER. RESTORED AREAS INCLUDE, BUT ARE NOT LIMITED TO TRENCH BACKFILL, SIDE SLOPES, FENCES, DRAIN PIPES, DRAINAGE DITCHES, DRIVEWAYS, LANDSCAPING, EXISTING GRADE ELEVATIONS.
14. THE GENERAL CONTRACTOR IS RESPONSIBLE FOR PLACEMENT OF ALL SLEEVES UNDER CONCRETE PAVING AS INDICATED ON THE PLANS.
15. ADEQUATE MEASURES SHALL BE TAKEN TO PREVENT EROSION. IN THE EVENT THAT SIGNIFICANT EROSION OCCURS AS A RESULT OF CONSTRUCTION, THE CONTRACTOR SHALL RESTORE THE ERODED AREA TO ORIGINAL CONDITION.
16. DISCREPANCIES IF ANY, SHOULD BE BROUGHT TO THE ATTENTION OF THE LANDSCAPE ARCHITECT/ ENGINEER BEFORE WORK COMMENCES.
17. ALL CONSTRUCTION SHALL CONFORM TO ALL APPLICABLE CODES AND ORDINANCES (FEDERAL, STATE, LOCAL, AND HEALTH DEPARTMENTS), EXCEPT WHERE REQUIREMENTS OF CONTRACT DOCUMENTS ARE MORE STRINGENT.
18. NO DESIGN MODIFICATIONS SHALL BE MADE WITHOUT THE OWNER'S AND/ OR LANDSCAPE ARCHITECT/ ENGINEERS APPROVAL.

FLOW TRAILS- SITE- GRADING & DRAINAGE NOTES

1. FINAL HEIGHT AND SHAPE OF EXCAVATION TO BE VERIFIED BY LANDSCAPE ARCHITECT/ ENGINEER IN THE FIELD.
2. ALL SPOT ELEVATIONS ARE FOR TOP OF FINISH WORK UNLESS OTHERWISE NOTED.
3. MINIMUM SLOPE FOR ALL CONCRETE FINISH WORK SHALL BE 1%. WATER MUST DRAIN TOWARDS DIRECTION OF FLOW ARROWS AND FOLLOW OVERALL DESIGN INTENT.
4. ALL AREAS DISTURBED BY GRADING OPERATIONS TO BE FINE GRADED.
5. VERIFY LOCATION AND DEPTH OF ALL UTILITIES PRIOR TO COMMENCING WORK.
6. REFER TO SECTIONS, DETAILS AND PROFILES FOR HEIGHT, RADII AND PROFILES.
7. ALL FINE GRADING OF EARTHWORK SHALL BE INSPECTED WITH TEMPLATES CUT TO THE SPECIFIED RADII/ ANGLE. CONTRACTOR TO PROVIDE SHOP DRAWINGS FOR ALL TEMPLATES/ SCREEDS TO BE USED FOR EARTHWORK TOLERANCES FOR APPROVAL BY LANDSCAPE ARCHITECT/ ENGINEER.
8. CONTRACTOR TO PROTECT ALL EXCAVATIONS FROM SOIL EROSION AND WATER SATURATION AT ALL TIMES USING APPROPRIATE CONSTRUCTION METHODS. LOSS OF SOIL PROFILE DURING CONSTRUCTION SHALL BE REPLACED WITH APPROPRIATE SOIL COMPOSITION AND COMPACTION METHODS TO MATCH LOSS SOIL.

FLOW TRAILS- SITE- SURVEY NOTES

1. LOCATE ALL SURVEY MARKS INCLUDING BENCH MARKS AND PROPERTY LINES IN ORDER THAT THE EXACT LINES OF CONSTRUCTION LIMITS AND GRADES MAY BE DETERMINED. BRING ANY DISCREPANCIES TO THE OWNER'S REPRESENTATIVE IMMEDIATELY BEFORE PROCEEDING WITH WORK.
2. VERIFY ENTIRE LAYOUT PRIOR TO START OF CONSTRUCTION WITH PROJECT OWNER'S REPRESENTATIVES AND LANDSCAPE ARCHITECT/ ENGINEER.
3. LOCATE AND PROTECT CONTROL POINTS PRIOR TO STARTING SITE WORK AND PROTECT ALL PERMANENT REFERENCE POINTS DURING ENTIRE CONSTRUCTION. REPLACE PROJECT CONTROL POINTS WHICH MAY BE LOST OR DESTROYED DURING CONSTRUCTION.

FLOW TRAILS- SITE- EXISTING CONDITIONS & DEMOLITION NOTES

1. ALL MATERIAL "TO REMAIN" SHALL BE PROTECTED DURING CONSTRUCTION.
2. ALL MATERIALS "TO BE REMOVED" SHALL BE TAKEN FROM THE SITE AND DISPOSED OF PROPERLY.
3. IT IS THE CONTRACTOR'S RESPONSIBILITY TO INSPECT THE JOB SITE TO BECOME FAMILIAR WITH ALL EXISTING CONDITIONS THAT COULD AFFECT THE INSTALLATION OF ANY WORK SET FORTH IN THESE PLANS PRIOR TO SUBMITTING A BID.
4. THE CONTRACTOR SHALL BE RESPONSIBLE FOR VERIFYING THE EXISTENCE AND LOCATION OF ANY UTILITIES THAT MAY BE NEEDED OR AVOIDED IN THE DEMOLITION PHASE IN ADVANCE OF ANY CONSTRUCTION. ASD DOES NOT GUARANTEE ANY LOCATIONS REFERENCED.
5. THE CONTRACTOR SHALL CONTACT ALL UTILITY ENTITIES AND OWNER FOR EXISTING LOCATIONS PRIOR TO ANY CONSTRUCTION ACTIVITY.
6. THE CONTRACTOR SHALL PROVIDE TRAFFIC CONTROL AS NECESSARY DURING CONSTRUCTION.
7. THE CONTRACTOR SHALL OBTAIN ALL NECESSARY PERMITS PRIOR TO CONSTRUCTION.

ISSUED SETS		
Date	Description	
01/05/2024	DD SUBMITTAL For Review Only	
REVISIONS		
No.	Date	Description

LANDSCAPE ARCHITECT
BENDER WELLS CLARK DESIGN
 830 N. ALAMO ST.
 SAN ANTONIO, TEXAS 78215



BENDER WELLS CLARK DESIGN

Landscape Architecture

Urban Design

Planning

830 North Alamo Street
 San Antonio, Texas 78215

210-692-9221
 www.bwcdesign.com

© 2023 Bender Wells Clark Design
 All rights reserved. No part of this document may be reproduced or utilized in any form without prior written authorization of Bender Wells Clark Design.

O. P. Schnabel Bike Park
 Bike Park
 2022 Bond Improvements

9700 Rochelle Road
 San Antonio Tx 78240

This drawing and the design were prepared specifically for this site and client and does not apply to any other projects. The reuse of this drawing for other projects is prohibited. Use of this set of drawings requires appropriate authorization from Bender Wells Clark Design.

LANDSCAPE ARCHITECT'S LICENSURE

THESE DOCUMENTS ARE INCOMPLETE AND ARE RELEASED FOR INTERIM REVIEW ONLY, AND NOT INTENDED FOR REGULATORY APPROVAL, BIDDING, PERMIT, OR CONSTRUCTION PURPOSES.

Drawn By : MM/ MJ Checked By : MM

SHEET TITLE & NUMBER:

BIKE PARK
 FLOW TRAIL NOTES

BP-01.03

SKILLS COURSE CONSTRUCTION NOTES

Trail Work Specifications
All trail work shall be done according to the specifications and typicals included in this document. When field conditions do not pertain to specifications provided the work shall be done in accordance with the 2007 edition of the USDA Trail Construction and Maintenance Notebook, the 2007 edition of Managing Mountain Biking, 2004 edition of the IMBA Trail Solutions Guide, and the 2017 edition of Guidelines for a Quality Trail Experience. Refer to these publications for details and descriptions of trail maintenance and construction. Deviation from these specifications will be allowed with the permission or at the direction of the Client.

1.1 Trail Alignment
Trail alignments have been designed in Autocad, these alignments represent the approved corridor. The approved corridor extends 20' on each side of original alignment, but slight field refinements and revisions are anticipated as trails are flagged in the field by the selected Trail Contractor. The Client may approve adjustments to the alignment within this corridor to improve sustainability, improve the trail experience, reduce impact, and improve build efficiency. Material, such as stone, may be harvested within this corridor as long as that harvesting does not negatively impact the trail experience or stability. Trail Contractor shall create an exact final alignment and location for each trail and trail feature. The alignments and locations shall meet appropriate specifications as provided in the construction documents. The alignment, location, design, and construction of each individual trail shall conform to the specifications, intent, character, and description for that specific trail as described in the construction documents. If conflicts arise in trail alignments, features, armoring, vegetation, landscaping, irrigation, and/or other items, Trail Contractor is required to immediately contact Owner's Representative for resolution before proceeding. The Trail Contractor shall work with the Owner's Representative to identify the need to further refine or adjust construction notes, location or types of trails or features, and make minor adjustments as soon as identified by the contractor. The trail flagging delineates the center of the approved trail corridor and desired trail alignment.

1.2 Technical Trail Features (TTFs)
The feature location plans provide quantities and feature types, but are diagrammatic and do not reflect an exact final alignment, location, or dimension for each feature. The Trail Contractor shall determine exact final location and dimension of all TTFs based upon final trail alignment, trail flow, character, difficulty, and surrounding terrain. It is the Trail Contractor's responsibility to ensure that final dimensions of TTFs (height, length, radius, width, etc.) flow appropriately with the speed of travel, other features and surrounding trails. TTF placements are required to include an optional line or bypass trail that provides users with an open and obvious route to avoid the TTF. Refer to details for typical detail. All manufactured TTF lengths are linear, not chord lengths. All manufactured TTF heights are from top of concrete footing or earth anchor to top of decking. All TTFs to be pre-engineered and designed. TTFs to be American Ramp Company or equal. Substitutes shall require approval by Owner's Rep. All manufactured TTFs will be sourced from insured bike park feature manufacturer and supplied by other. Feature manufacturer shall hold product liability insurance. TTFs are quantified separately in the bid form.

1.3 Turns
Turns on the trail system shall be cambered/banked/bermed as necessary according to the specifications, drawings, intended riding experience, trail flow, trail speed, and difficulty. Turns shall be built according to the trail type and difficulty level as specified in the construction documents. Turns shall be constructed according to design and sustainability guidelines as set forth in Building Sweet Singletrack. Turns shall be built with proper drainage and grade reversals before and after the turn. Construction of Turns are included in the base trail cost and will not be quoted as separate units.

1.4 Vertical Undulations / Features
The trails should have vertical undulations such as rollers, jumps, grade reversals, and dips as necessary according to the specifications, drawings, intended riding experience, trail flow, trail speed, and difficulty. Construction of typical trail features that are approximately 24" or less in height are included in the base trail cost and will not be quoted as separate feature units unless specifically identified in the bid form (ex. rollers, grade reversals, jumps <24").

1.5 Trail Drainage
All finished tread must provide positive drainage off of the trail. The finished tread shall show no signs of erosion prior to final payment. Drainage shall promote sheet flow off of the tread, riling from shallow concentrated flow shall not occur on trail tread. Where necessary, Trail Contractor may construct shallow porous stormwater infiltration areas and swales adjacent to the trail to manage surface water drainage, provided they are constructed in an appropriate manner and do not create a hazard.

1.6 Grade Reversals (Rolling Grade Dip) / Drains
A designed grade reversal or constructed rolling grade dip shall occur at least every 100-150 feet along the trail alignment, preferably more frequently. All grade reversals must be strongly anchored to discourage short cutting. Grade reversals shall have cross slopes that promote positive drainage off trail and down slope of the tread. Cross slopes shall be twice that of the average tread cross slope (minimum 10%, maximum 20%). The grade reversal transition shall be gradual and the feature shall cover a distance of at least 10 feet of trail. Ref. Details.

1.7 Trail Corraling
Trail Contractor shall provide speed-reducing features and curves in the trail alignment to slow riders before reaching trail intersections. Speed-reducing features may include boulders, cut trees or in extreme cases fencing as obstacles. Contractor shall furnish and install landscape boulders on the trail system where necessary to help anchor the apex of turns, help define and improve intersections, prevent short-cutting, and to otherwise enhance the edge of the trail corridor where necessary. Landscape boulders shall be native rock partially buried into soil a minimum of 50% of the boulders height below grade and per plan.

1.8 Rock Armor / Tech Trails
Rock armoring shall be installed where necessary to prevent trail erosion, harden wet tread, or provide tread texture. Rock armoring should utilize local rocks. When possible rocks shall be harvested from the work site. Stone pitching, a form of rock armoring, shall be at least ten (10) inches deep with a minimum of seven (7) inches of the rock buried below the surface of the surrounding grade. Stones should be stable and aligned perpendicular to the direction of travel. Each end of a pitched section shall be supported by larger "bookend" stones embedded in the ground to prevent movement of the rock armor. Surface depth variation and unavoidable obstacles shall adhere to IMBA trail difficulty rating system. Rocks shall not move. Flagstone paving, a form of rock armoring, shall be two (2) inches to 24 inches thick and 12 inches to 48 inches wide. Voids larger than 2" shall be filled with compacted crushed stone and topped with compacted native soil. Rocks shall not move. Rock armor shall be constructed such that the desirable path of travel is the tread and not the surrounding forest floor. Additional guide stones may be required if the final surface of the trail appears more rugged than the adjacent landscape. All rock embedded in the trail surface should be stable. When used in structures, care will be taken to match rock to the immediate surroundings; grain patterns, lichen growth, etc. Excess tool marks on rocks is not acceptable. Contractor shall determine the appropriate ratio of "stone pitching" vs. "flagstone paving" for the particular trail segment.

1.9 Rock Placement at Drainage Crossings
Trail Contractor shall construct a sub-base of crushed rock under the Rock Armor layer at drainage crossings. Possible locations include very low-lying terrain where water ponding is probable, significant water drainage crossings, or other areas expected to have very poor drainage. Rock placement must not obstruct flow above or below the drainage crossing. It should be placed in such a way that water runs through the intended channel. Refer to Details.

1.10 Rock Procurement
All rock armoring, rock gardens, and landscape boulders to be used in trail construction shall first be obtained from on site stockpiles or designated areas to the extent possible. Given the lack of suitable native stone present on the site, the contractor should anticipate the need to source suitable stone elsewhere.

1.11 Boulders
Boulders used in rock armor, for TTFs or landscaping shall have a character and shape consistent with native landscape rock settings. If no native landscape rock is present, the contractor shall source boulders that are angular an irregular with properties that are positive for riding on and construction. Boulders shall be a range of sizes and shapes, minimum size is 2'Wx1.5'Hx2.5'L. To the greatest extent possible, rocks shall be placed in their final locations with the lichen or weathered side exposed.

1.12 Trail Surfacing Material
The intent of the Trail Surfacing Material is to cover the existing soils as called for in the plan set (typically on jump lines and gravity trails) with a well-balanced surface that facilitates drainage, compacts well, and that performs reasonably in both wet and dry weather conditions. Trail surfacing material shall be incidental to the unit rate for trail construction. All imported soil will require lab testing to meet the following requirements: 1. Surface material shall be composed of between 65-75% clay and 35-25% sand. 2. Material shall be natural, uncontaminated, and free of organic material, vegetation, waste, recycled concrete, asphalt, noxious weeds/seeds and other deleterious matter. 3. Material comprised wholly of rock aggregate, gravel, road base, crusher fines or similar is not acceptable due to unfavorable looseness, surface marbles, lack of binding, and other negative characteristics for bike riding. 4. The trail surface material must be tested in both wet and dry conditions on the sample trail sections described in the performance specifications. Modifications to the material may be necessary based on the sample test. Owner's Representative must approve the material before additional construction may proceed. Trail Surfacing Material is not incidental to the unit price for Natural Surface Trails and is quantified and identified as a separate bid item on the bid form.

1.13 Compaction
All trail sub grades, trail treads, trail surfacing materials, backslopes, rollers, berms, fill, and terrain enhancements shall be compacted to a minimum 92% Proctor and in a manner that will support the intended use.

1.14 Quantities
For all specifications that contain more or less quantities, it shall be understood and agreed that quantities listed in the specifications are estimated only and may be increased or decreased in accordance with the requirements of the owner.

1.15 Fill Material
Fill needed for trail construction, berms, rollers, or other features may be generated during trail excavation, borrowed from surrounding landscape where appropriate, borrowed from onsite stockpiles, or imported if necessary. Fill material shall be uncontaminated and free of organic material, trash, noxious weeds/seeds, and other objects. Fill material shall be placed, graded, and compacted by Trail Contractor in a manner that will support the intended use. The non-riding surfaces of berms, rollers, landscape mounds, or other terrain enhancements created by the Trail Contractor shall not exceed a 1:1 slope.

1.16 Backslope
The backslope of trail should be graded to a slope that limits the amount of site disturbance and does not exceed a 1:1.5 slope or until it matches the existing ground. The edge between existing ground surface and backslope shall be smooth and not impede the flow of water or provide vertical drop between the existing ground surface and backslope. Any backslope that is created by fill shall be compacted to 90% Proctor.

1.17 Trail Finished Condition
Finish and grading of backslope, down slope spoils, and drainage features shall leave surface that matches the texture of the surrounding forest floor. Finished tread should be compacted to 92% Proctor and provide positive drainage off trail. Finished tread shall incorporate fixed natural and native roots and rocks according to specifications and dependent on trail type. Runoff shall be diverted during sheet flow prior to shallow concentrated flow. Cross slopes may vary (5% minimum, 10% maximum), including cambering of turns, but water must exit the trail in sheet flow without causing erosion or puddling on, the trail. Locations intended to drain water from the trail shall have a minimum slope of 10%, unless authorized by the Client or Client's Representative.

1.18 Spoils Stabilization
All excavated materials not used in the trail tread or other trail structures must be stabilized. Spoils shall not be placed in drainages, swales, ephemeral streams, wetlands, or any area known to convey water during wet weather events. When possible, spoils should be mulched with native materials to discourage erosion while native seed stocks reestablish. In areas without adequate native mulch, seed-free straw and suitable native seed may substitute. In certain circumstances, installation of formal erosion control measures may be required. It is the Contractor's responsibility to conform with all local, state, and federal stormwater regulations.

1.19 Corridor Clearing
The finished trail corridor shall extend horizontally a minimum of 3.0 feet from the edge of the trail tread to both sides and shall be a minimum vertically eight (8) feet high and higher in the case of jump and flow trail types as determined to be necessary by the Owner's Representative. Corridor clearing shall be confined to within five (6) feet of trail alignment centerline.

1.20 Spoils
The trail tread shall consist of mechanically compacted earth or rock. No organic material may be within trail tread. Tread shall be mineral soil or rock. All stumps shall be excavated and removed from the trail tread. Any stumps resulting from corridor clearing should be excavated and removed. Stumps not removed in the corridor may not pose an unreasonable risk. Spoils shall be stabilized as outlined in "Stabilization". Any downslope spoils must be distributed to encourage drainage off the trail. Spoils may be distributed upstope on hillsides with a slope angle less than 30%. Spoils and disturbed areas outside of the trail tread must be stabilized with a covering of forest mulch or leaves. In areas with insufficient duff, weed-free straw may be substituted for forest materials. Excess soil shall not be distributed into drainages or adjacent to streams. Any woody debris not used in trail closure should be removed from sight of the trail or arranged to blend into the landscape.

1.21 Debris and Woody Material
Any woody debris not used in trail closure should be removed from sight of the trail or arranged to blend into the landscape. Cut and scatter all branches and brush to maximum height of 18 inches above the existing ground surface. No debris shall be left within 10 feet of trail, unless placed as anchors or stabilization. Butt-ends of any sawed limbs shall be placed facing away from trail. All branches trimmed shall be cut to a main branch or trunk to prevent stabs or "coat hangers". Woody material such as stumps, logs, and brush shall be removed from the trail tread. Stumps less than 12" diameter at breast height (DBH) within three (3) feet of the trail tread will be removed or flush cut to existing ground surface.

1.22 Test Riding
Trail Contractor shall thoroughly test ride all trails and trail features, by bike with appropriately skilled rider, to ensure the specified riding experience, design, flow, rhythm, character, difficulty, and specifications are met. Testing shall be performed during the trail alignment and trail feature location process, as well as during construction and following construction, to the extent possible and in consultation with Owner's Representative. Trails and features shall be modified and corrected as necessary until performance specifications are met.

1.23 Sample Trail Section
Contractor shall construct sample segments of a minimum of 50 linear feet of each trail type and 20 square feet of each armoring type as indicated in the construction plans. These sections shall contain a complete sample of the construction methods, materials, and workmanship intended for the project. The Owner's Representative must accept work before additional construction may proceed. Corrections shall be executed as necessary for acceptance. The accepted samples shall be retained during construction as a standard of work. Accepted samples shall be part of the actual trail system. Upon completion of sample, 2,500' lengths of individual trail may be constructed at a time. Owner's representative to approve 2,500' section prior to commencement of next section.

1.24 Bridges
Any required bridges shall adhere to local codes and regulations. Design and determining exact location(s) shall be the responsibility of the selected contractor. Shop drawing shall be provided and must be approved by Owner's Representative. Bridges are not incidental to the unit price for Natural Surface Trails and are quantified and identified as a separate bid item on the bid form.

1.25 Contractor Coordination
Trail contractor shall be responsible for any coordination with General Contractor and Subcontractors as required to complete all operations.

1.26 Missing Specification
Any specifications not addressed in these notes are to be covered by City Master Spec Supplements.

CHIP SEAL MOUNTAIN BIKE OPTIMIZED TRAIL
Chip Seal Trail will use rolling contour and lift and tilt (where required for drainage) construction methods and will have a medium frequency of rollers, berms and table top and rollable gap jumps (3-5 PER 100LF), or as quantified in construction documents.

All trail construction shall comply with the specifications, drawings, requirements, and design intent prescribed in the construction and contract documents. Additional resources include "Trail Solutions, IMBA's Guide to Building Sweet Singletrack" (2004) and "Managing Mountain Biking" (2007). Modifications shall be approved by Owner's Representative. Trail shall include Technical Trail Features (TTF) in the types and locations called for on the plans and referenced in detail drawings.

Completed products shall reflect professional workmanship in appearance, quality, and attention to detail. Trails and features shall be well integrated into site, aesthetically pleasing in appearance, and well-shaped, crafted, and finished according to commonly accepted best practices for high quality and sustainable mountain biking trails. Work must be completed to the satisfaction of the Owner's Representative.

Trail Contractor shall thoroughly test ride all trails and trail features, by bike with appropriately skilled rider, to ensure the specified riding experience, design, flow, rhythm, character, difficulty, and specifications are met. Testing shall be performed during the trail alignment and trail feature location process, as well as during construction and following construction, to the extent possible and in consultation with Owner's Representative. Trails and features shall be modified and corrected as necessary until performance specifications are met.

Following test ride and approval of final alignment and shapes, contractor shall import and compact road base (3/4 minus) or similar at 3-4 inches depth. Site visit and test ride required for sign off prior to applying chip seal.

Contractor shall apply two layers of tar (CRS2-P if available and if not CRS2 is suitable) and two compacted layers of chip seal (3/8 clean chipped material for the initial layer and a more decorative 3/8 minus for the second (top) layer.

Contractor must submit a surfacing mixture sample(s) (1 gallon) to the engineer or owner's representative prior to delivery to the site. Color and texture of final chip layer to be approved by engineer or owner's representative prior to delivery and/or installation.

ISSUED SETS	
Date	Description
01/05/2024	DD SUBMITTAL For Review Only

REVISIONS		
No.	Date	Description

LANDSCAPE ARCHITECT
BENDER WELLS CLARK DESIGN
830 N. ALAMO ST.
SAN ANTONIO, TEXAS 78215

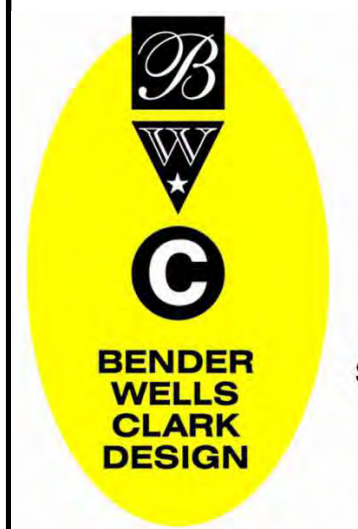

Landscape Architecture
Urban Design
Planning
830 North Alamo Street
San Antonio, Texas 78215
210-692-9221
www.bwcdesign.com

© 2023 Bender Wells Clark Design
All rights reserved. No part of this document may be reproduced or utilized in any form without prior written authorization of Bender Wells Clark Design.

O. P. Schnabel Bike Park
Bike Park
2022 Bond Improvements
9700 Rochelle Road
San Antonio Tx 78240
This drawing and this design was prepared specifically for this site and client and does not apply to any other projects. The user of this drawing for any other project is prohibited. Use of this set of drawings requires appropriate authorization from Bender Wells Clark Design.

LANDSCAPE ARCHITECT'S LICENSURE

THESE DOCUMENTS ARE INCOMPLETE AND ARE RELEASED FOR INTERIM REVIEW ONLY, AND NOT INTENDED FOR REGULATORY APPROVAL, BIDDING, PERMIT, OR CONSTRUCTION PURPOSES.

Drawn By : MM/ MJ Checked By : MM

SHEET TITLE & NUMBER:
BIKE PARK
SKILLS COURSE NOTES





BP-01.04

Date: Jan 05, 2024, 2:40pm User ID: Mitch
 File: C:\Users\Mitch\actionsportsdesign.com\PROJECTS - Documents\TX-San Antonio-OP Schnabel Bike Park-23-050-BP-04-Construction Documents\Sheet Files\BP-REFERENCE PLAN.dwg

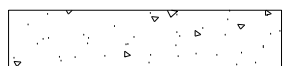

BIKE PARK-REFERENCE PLAN

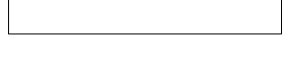
MATERIALS PLAN - LEGEND

-  CHIP SEAL TRAIL-TAN GRANITE BP-04.01-05
-  SHOTCRETE TRAIL-ACRYLIC SURFACE-TAN BP-03-01-05
-  CONCRETE WALKWAY
-  LIMESTONE BLOCK RETAINING/ SEAT WALL SEE DTL 7-BP-06.01
-  SIGNAGE-WAYFINDING SEE SHT 07.02

BIKE PARK - NOTES

1. THE LOCATIONS OF UNDERGROUND UTILITIES SHOWN ARE BASED ON THE SURVEY PROVIDED. THE CONTRACTOR SHALL NOTIFY THE STATE 811 DIG ALERT, PROPER LOCAL AUTHORITIES AND RESPECTIVE UTILITY COMPANIES TO CONFIRM THE LOCATION OF ALL EXISTING UTILITIES BEFORE COMMENCING WORK. ANY DAMAGE DUE TO FAILURE OF THE CONTRACTOR TO CONTACT THE PROPER AUTHORITIES SHALL BE BORNE BY THE CONTRACTOR.
2. CONTRACTOR(S) SHALL THOROUGHLY FAMILIARIZE THEMSELVES WITH ALL CONSTRUCTION DOCUMENTS AND SITE CONDITIONS PRIOR TO BIDDING AND PRIOR TO CONSTRUCTION.
3. ANY DISCREPANCIES BETWEEN DRAWINGS AND SITE CONDITIONS SHALL BE REPORTED IMMEDIATELY TO THE BIKE PARK DESIGNER FOR CLARIFICATION AND RESOLUTION PRIOR TO BIDDING OR CONSTRUCTION.

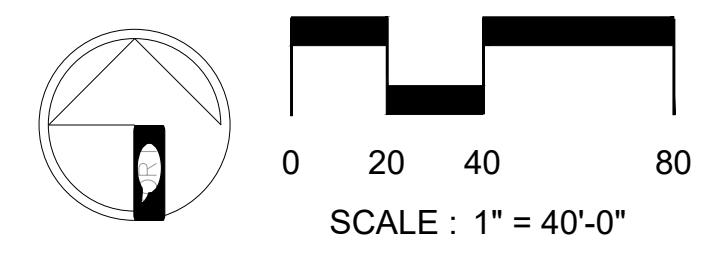

ISSUED SETS	
Date	Description
01/05/2024	DD SUBMITTAL For Review Only

REVISIONS		
No.	Date	Description

LANDSCAPE ARCHITECT
BENDER WELLS CLARK DESIGN
 830 N. ALAMO ST.
 SAN ANTONIO, TEXAS 78215

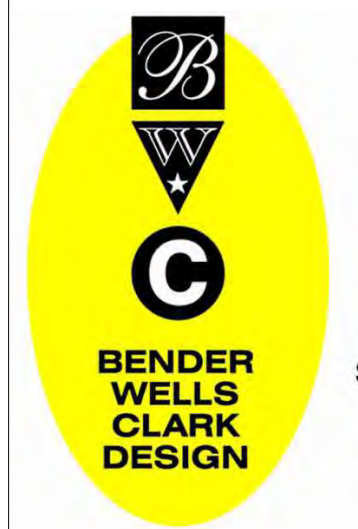

Landscape Architecture
Urban Design
Planning
 830 North Alamo Street
 San Antonio, Texas 78215
 210-692-9221
 www.bwcdesign.com

© 2023 Bender Wells Clark Design
 All rights reserved. No part of this document may be reproduced or utilized in any form without prior written authorization of Bender Wells Clark Design.

**O. P. Schnabel Bike Park
 Bike Park
 2022 Bond Improvements**

**9700 Rochelle Road
 San Antonio Tx 78240**

This drawing and the design work prepared hereon are the property of Bender Wells Clark Design. The reproduction or use of this drawing for any other project is prohibited. Use of this set of drawings requires appropriate authorization from Bender Wells Clark Design.

LANDSCAPE ARCHITECT'S LICENSURE

THESE DOCUMENTS ARE INCOMPLETE AND ARE RELEASED FOR INTERIM REVIEW ONLY, AND NOT INTENDED FOR REGULATORY APPROVAL, BIDDING, PERMIT, OR CONSTRUCTION PURPOSES.

Drawn By : MM/ MJ Checked By : MM

SHEET TITLE & NUMBER:

BIKE PARK
 REFERENCE PLAN

BP-02.01

Date: Jan 05, 2024, 2:41pm User ID: Mitch
 File: C:\Users\Mitch\actionsportsdesign.com\PROJECTS - Documents\TX-San Antonio-OP Schnabel Bike Park-23-050-BP-04-Construction Documents\Sheet Files\BP-FLOW LINES-REFERENCE PLAN.dwg

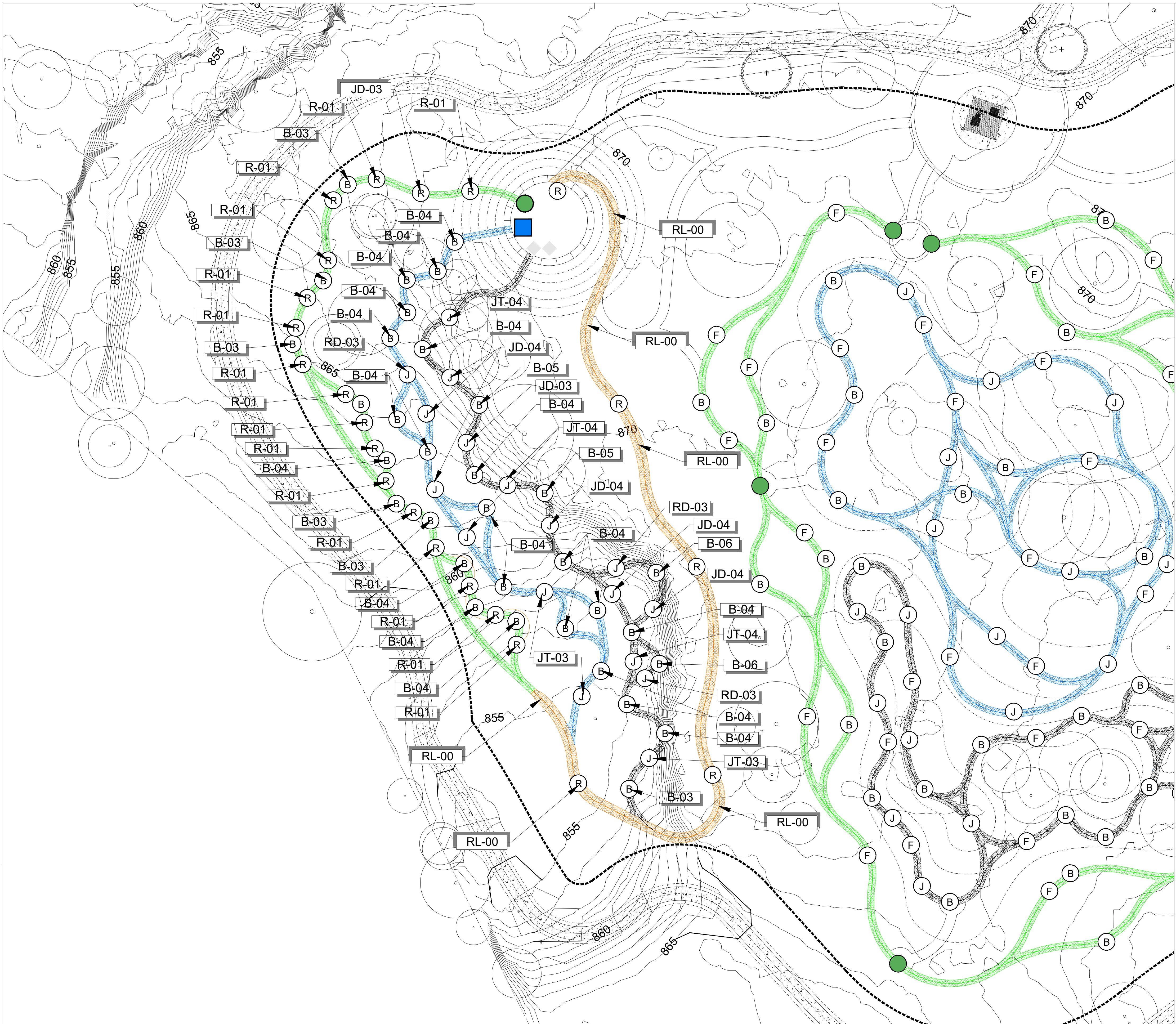

FLOW LINES-REFERENCE PLAN

FLOW LINES FEATURE LEGEND

SYMBOL	DESCRIPTION
R-01	ROLLER-SINGLE-1.5'- SEE (1-BP-05.01)
R-02	ROLLER-SINGLE-2.0'-SEE (2-BP-05.01)
R-03	ROLLER-SINGLE-2.5'-SEE (3-BP-05.01)
R-04	ROLLER-SINGLE-3.0'-SEE (4-BP-05.01)
RD-01	ROLLER-DOUBLE-1.5'-SEE (1-BP-05.02)
RD-02	ROLLER-DOUBLE-2.0'-SEE (2-BP-05.02)
RD-03	ROLLER-DOUBLE-2.5'-SEE (3-BP-05.02)
RD-04	ROLLER-DOUBLE-3.0'-SEE (4-BP-05.02)
JD-03	JUMP-DOUBLE-3.0' to 4.0'-SEE (1-BP-05.03)
JD-04	JUMP-DOUBLE-4.0' to 5.0'-SEE (2-BP-05.03)
JT-03	JUMP-TABLE-3.0' to 4.0'-SEE (3-BP-05.03)
JT-04	JUMP-TABLE-4.0' to 5.0'-SEE (4-BP-05.03)
B-03	BERM-3.0'-SEE (1-BP-05-04)
B-04	BERM-4.0'-SEE (2-BP-05-04)
B-05	BERM-5.0'-SEE (3-BP-05-04)
B-06	BERM-6.0'-SEE (4-BP-05-04)
RL-00	RETURN LINE-CHIP SEAL-(7-BP-06-03)

FLOW LINES - NOTES

1. THE LOCATIONS OF UNDERGROUND UTILITIES SHOWN ARE BASED ON THE SURVEY PROVIDED. THE CONTRACTOR SHALL NOTIFY THE STATE 811 DIG ALERT, PROPER LOCAL AUTHORITIES AND RESPECTIVE UTILITY COMPANIES TO CONFIRM THE LOCATION OF ALL EXISTING UTILITIES BEFORE COMMENCING WORK. ANY DAMAGE DUE TO FAILURE OF THE CONTRACTOR TO CONTACT THE PROPER AUTHORITIES SHALL BE BORNE BY THE CONTRACTOR.
2. CONTRACTOR(S) SHALL THOROUGHLY FAMILIARIZE THEMSELVES WITH ALL CONSTRUCTION DOCUMENTS AND SITE CONDITIONS PRIOR TO BIDDING AND PRIOR TO CONSTRUCTION.
3. ANY DISCREPANCIES BETWEEN DRAWINGS AND SITE CONDITIONS SHALL BE REPORTED IMMEDIATELY TO THE TRACK DESIGNER FOR CLARIFICATION AND RESOLUTION PRIOR TO BIDDING OR CONSTRUCTION.

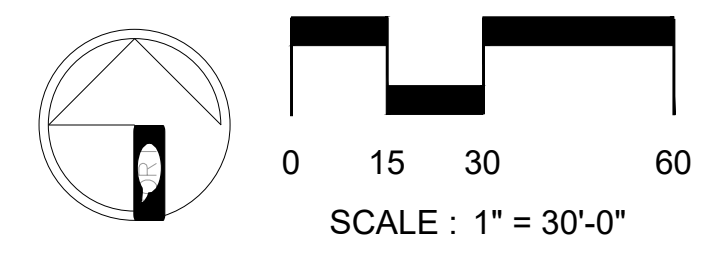

ISSUED SETS

Date	Description
01/05/2024	DD SUBMITTAL For Review Only

REVISIONS

No.	Date	Description
-----	------	-------------

LANDSCAPE ARCHITECT
BENDER WELLS CLARK DESIGN
 830 N. ALAMO ST.
 SAN ANTONIO, TEXAS 78215

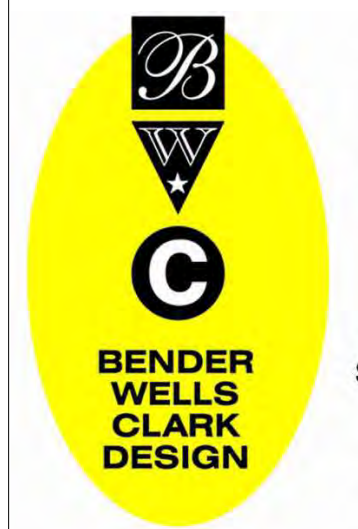

Landscape Architecture
Urban Design
Planning
 830 North Alamo Street
 San Antonio, Texas 78215
 210-692-9221
 www.bwcdesign.com

© 2023 Bender Wells Clark Design
 All rights reserved. No part of this document may be reproduced or utilized in any form without prior written authorization of Bender Wells Clark Design.

O. P. Schnabel Bike Park
Bike Park
2022 Bond Improvements
 9700 Rochelle Road
 San Antonio Tx 78240

This drawing and the design were prepared specifically for this site and client and does not apply to any other projects. The reuse of this design for any other project is prohibited. Use of this set of drawings requires appropriate authorization from Bender Wells Clark Design.

LANDSCAPE ARCHITECT'S LICENSURE

THESE DOCUMENTS ARE INCOMPLETE AND ARE RELEASED FOR INTERIM REVIEW ONLY, AND NOT INTENDED FOR REGULATORY APPROVAL, BIDDING, PERMIT, OR CONSTRUCTION PURPOSES.

Drawn By : MM/ MJ Checked By : MM

SHEET TITLE & NUMBER:

FLOW LINES
 REFERENCE PLAN

BP-03.01

Date: Jan 05, 2024, 2:41pm User ID: Mitch
 File: C:\Users\Mitch\actionsportsdesign.com\PROJECTS - Documents\TX-San Antonio-OP Schnabel Bike Park-23-050-BP-04-Construction Documents\Sheet Files\BP-FLOW LINES-MATERIALS PLAN.dwg

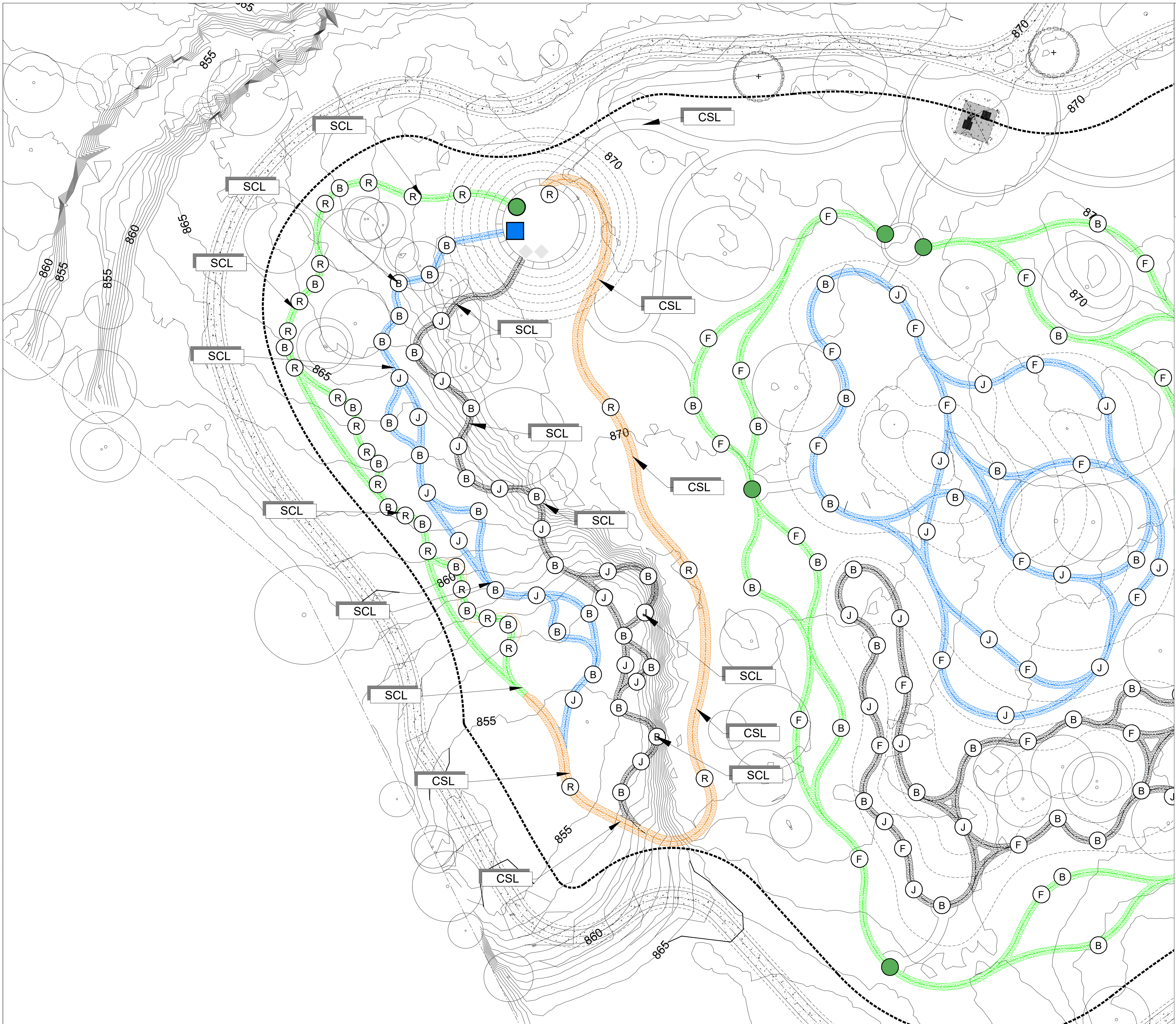

FLOW LINES-REFERENCE PLAN

FLOW LINES MATERIALS LEGEND

SYMBOL	DESCRIPTION
	SHOTCRETE LINE-ACRYLIC SURFACE- SEE (BP-05.05-1-9)
	CHIP SEAL RETURN LINE-SEE (BP-06.03-7)

FLOW LINES MATERIALS - NOTES

1. THE LOCATIONS OF UNDERGROUND UTILITIES SHOWN ARE BASED ON THE SURVEY PROVIDED. THE CONTRACTOR SHALL NOTIFY THE STATE 811 DIG ALERT, PROPER LOCAL AUTHORITIES AND RESPECTIVE UTILITY COMPANIES TO CONFIRM THE LOCATION OF ALL EXISTING UTILITIES BEFORE COMMENCING WORK. ANY DAMAGE DUE TO FAILURE OF THE CONTRACTOR TO CONTACT THE PROPER AUTHORITIES SHALL BE BORNE BY THE CONTRACTOR.
2. CONTRACTOR(S) SHALL THOROUGHLY FAMILIARIZE THEMSELVES WITH ALL CONSTRUCTION DOCUMENTS AND SITE CONDITIONS PRIOR TO BIDDING AND PRIOR TO CONSTRUCTION.
3. ANY DISCREPANCIES BETWEEN DRAWINGS AND SITE CONDITIONS SHALL BE REPORTED IMMEDIATELY TO THE BIKE PARK DESIGNER FOR CLARIFICATION AND RESOLUTION PRIOR TO BIDDING OR CONSTRUCTION.

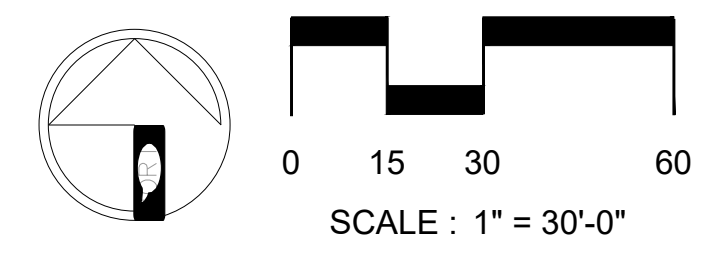

ISSUED SETS	
Date	Description
01/05/2024	DD SUBMITTAL For Review Only

REVISIONS		
No.	Date	Description

LANDSCAPE ARCHITECT
BENDER WELLS CLARK DESIGN
 830 N. ALAMO ST.
 SAN ANTONIO, TEXAS 78215

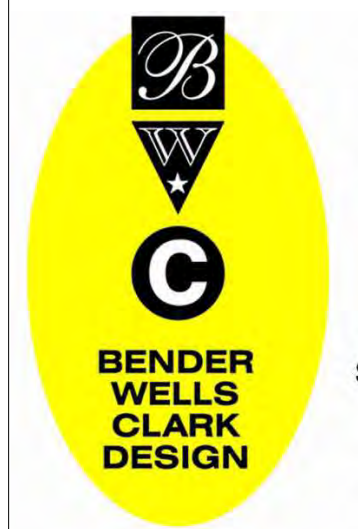

Landscape Architecture
Urban Design
Planning
 830 North Alamo Street
 San Antonio, Texas 78215
 210-692-9221
 www.bwcdesign.com

© 2023 Bender Wells Clark Design
 All rights reserved. No part of this document may be reproduced or utilized in any form without prior written authorization of Bender Wells Clark Design.

O. P. Schnabel Bike Park
Bike Park
2022 Bond Improvements
9700 Rochelle Road
San Antonio Tx 78240
This drawing and the design were prepared specifically for this site and client and does not apply to any other projects. The reuse of this design for any other project is prohibited. Use of this set of drawings requires appropriate authorization from Bender Wells Clark Design.

LANDSCAPE ARCHITECT'S LICENSURE

THESE DOCUMENTS ARE INCOMPLETE AND ARE RELEASED FOR INTERIM REVIEW ONLY, AND NOT INTENDED FOR REGULATORY APPROVAL, BIDDING, PERMIT, OR CONSTRUCTION PURPOSES.

Drawn By : MM/ MJ Checked By : MM

SHEET TITLE & NUMBER:

FLOW LINES MATERIALS PLAN

BP-03.02

Date: Jan 05, 2024, 2:52pm User ID: Mitch
 File: C:\Users\Mitch\actionsportsdesign.com\PROJECTS - Documents\TX-San Antonio-OP Schnabel Bike Park-23-050-BP\04-Construction Documents\Sheet Files\BP-FLOW LINES-GRADING PLAN-DESKTOP-151MM20

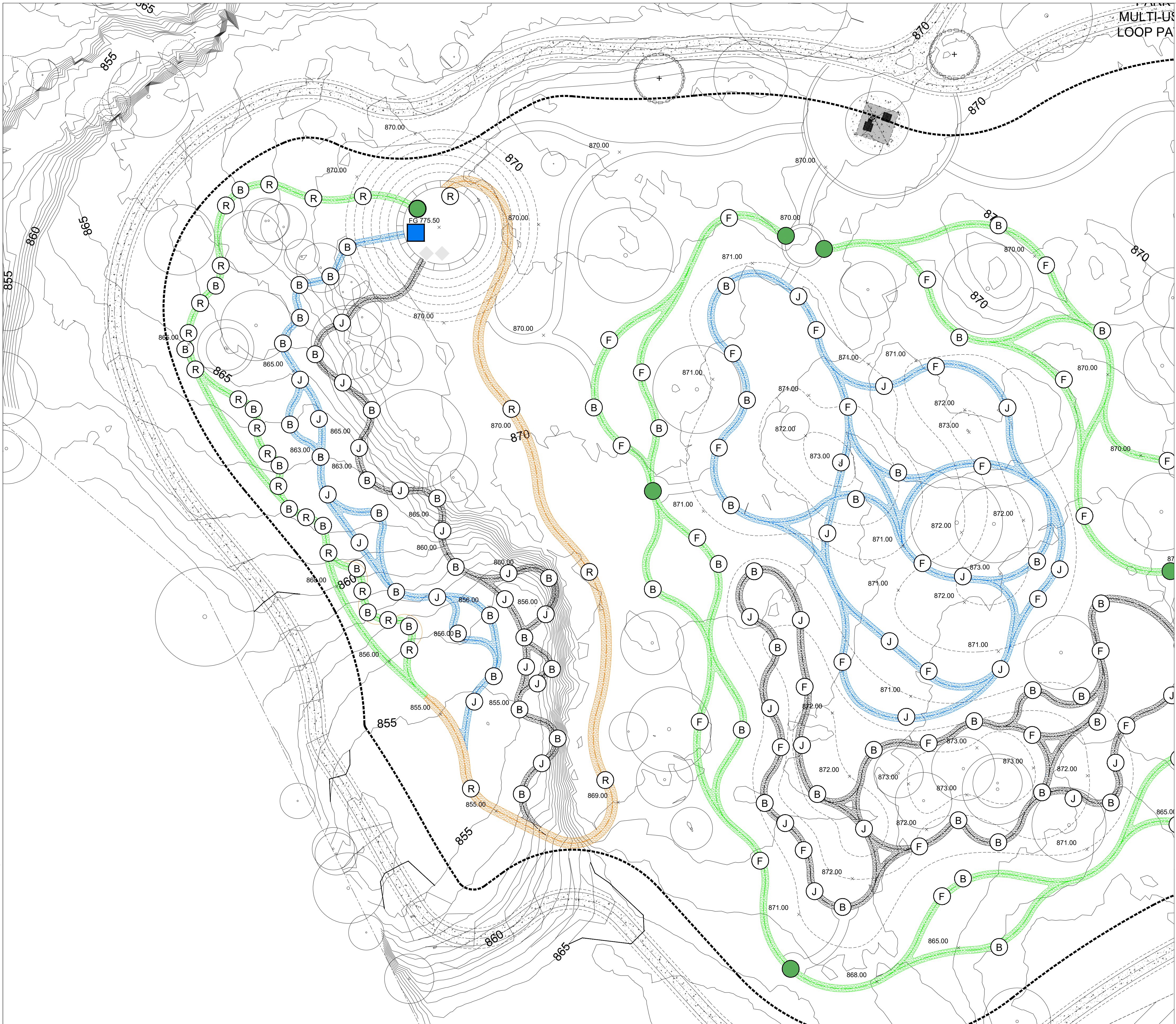

FLOW LINES-GRADING PLAN

GRADING & DRAINAGE LEGEND

SYMBOL	DESCRIPTION
—→	DIRECTION OF SURFACE FLOW
---	G.B. BREAK IN GRADE
---	F.L. FLOWLINE IN SWALE
TJ	TOP OF JUMP ELEVATION
TF	TOP OF FLOW LINE ELEVATION
+	DRAIN INLET

GRADING & DRAINAGE NOTES

1. FINAL HEIGHT AND SHAPE OF EXCAVATION TO BE VERIFIED BY BIKE PARK DESIGNER IN THE FIELD.
2. ALL SPOT ELEVATIONS ARE FOR TOP OF FINISH WORK UNLESS OTHERWISE NOTED.
3. MINIMUM SLOPE FOR ALL CONCRETE FINISH WORK SHALL BE 1%. WATER MUST DRAIN TOWARDS DIRECTION OF FLOW ARROWS AND FOLLOW OVERALL DESIGN INTENT.
4. MAXIMUM SIDEWALK CROSS SLOPE IS 2.0%.
5. MAXIMUM SIDEWALK LONGITUDINAL SLOPE IS 5.0%.
6. ALL AREAS DISTURBED BY GRADING OPERATIONS TO BE FINE GRADED.
7. VERIFY LOCATION AND DEPTH OF ALL UTILITIES PRIOR TO COMMENCING WORK.
8. REFER TO SECTIONS AND PROFILES FOR HEIGHT, RADII AND PROFILES.
9. ALL FINE GRADING OF EARTHWORK SHALL BE INSPECTED WITH TEMPLATES CUT TO THE SPECIFIED RADI/ ANGLE. CONTRACTOR TO PROVIDE SHOP DRAWINGS FOR ALL TEMPLATES/ SCREEDS TO BE USED FOR EARTHWORK TOLERANCES FOR APPROVAL BY BIKE PARK DESIGNER.
10. CONTRACTOR TO PROTECT ALL EXCAVATIONS FROM SOIL EROSION AND WATER SATURATION AT ALL TIMES USING APPROPRIATE CONSTRUCTION METHODS. AND LOSS OF SOIL PROFILE DURING CONSTRUCTION SHALL BE REPLACED WITH APPROPRIATE SOIL COMPOSITION AND COMPACTION METHODS TO MATCH LOSS SOIL.
11. CONTRACTOR TO VERIFY FEATURE ELEVATIONS WITH FLOW LINE DETAIL SECTIONS. IF A DISCREPANCY OCCURS, CONTRACTOR SHALL CONTACT BIKE PARK DESIGNER IMMEDIATELY.
12. CONTRACTOR TO REFER TO CIVIL PLANS FOR FINISH GRADE ELEVATIONS BEYOND FLOW LINES FOOTPRINT.

SURVEY NOTES

1. LOCATE ALL SURVEY MARKS INCLUDING BENCH MARKS AND PROPERTY LINES IN ORDER THAT THE EXACT LINES OF CONSTRUCTION LIMITS AND GRADES MAY BE DETERMINED. BRING ANY DISCREPANCIES TO THE OWNER'S REPRESENTATIVE IMMEDIATELY BEFORE PROCEEDING WITH WORK.
2. VERIFY ENTIRE LAYOUT PRIOR TO START OF CONSTRUCTION WITH PROJECT OWNER'S REPRESENTATIVES AND SKATE PARK DESIGNER.
3. LOCATE AND PROTECT CONTROL POINTS PRIOR TO STARTING SITE WORK AND PROTECT ALL PERMANENT REFERENCE POINTS DURING ENTIRE CONSTRUCTION. REPLACE PROJECT CONTROL POINTS WHICH MAY BE LOST OR DESTROYED DURING CONSTRUCTION.
4. CONTRACTOR SHALL VERIFY FINISH GRADE ELEVATIONS AS SHOWN ON CIVIL ENGINEER'S PLANS AND BRING ANY DISCREPANCIES TO THE OWNER'S REPRESENTATIVE IMMEDIATELY BEFORE PROCEEDING WITH WORK.

SPOT ELEVATION LEGEND

BW	BOTTOM OF WALL
TW	TOP OF WALL
BB	BOTTOM OF BANK
TB	TOP OF BANK
ES	EDGE OF SLAB
TS	TOP OF SLAB
TL	TOP OF LEDGE
BL	BOTTOM OF LEDGE
TC	TOP OF CURB
BC	BOTTOM OF CURB
TT	TOP OF TRANSITION
BT	BOTTOM OF TRANSITION
RIM	RIM OF DRAIN
INV	INVERT

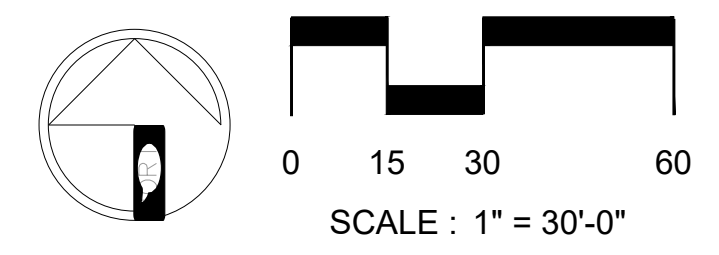

ISSUED SETS

Date	Description
01/05/2024	DD SUBMITTAL For Review Only

LANDSCAPE ARCHITECT
BENDER WELLS CLARK DESIGN
 830 N. ALAMO ST.
 SAN ANTONIO, TEXAS 78215

Landscape Architecture
Urban Design
Planning

830 North Alamo Street
 San Antonio, Texas 78215
 210-692-9221
 www.bwcdesign.com

© 2023 Bender Wells Clark Design
 All rights reserved. No part of this document may be reproduced or utilized in any form without prior written authorization of Bender Wells Clark Design.

O. P. Schnabel Bike Park
Bike Park
2022 Bond Improvements

9700 Rochelle Road
San Antonio Tx 78240

This drawing and the design were prepared specifically for this site and client and does not apply to any other projects. The reuse of this drawing for any other project is prohibited. Use of this set of drawings requires appropriate authorization from Bender Wells Clark Design.

LANDSCAPE ARCHITECT'S LICENSURE

THESE DOCUMENTS ARE INCOMPLETE AND ARE RELEASED FOR INTERIM REVIEW ONLY, AND NOT INTENDED FOR REGULATORY APPROVAL, BIDDING, PERMIT, OR CONSTRUCTION PURPOSES.

Drawn By : MM/ MJ Checked By : MM

SHEET TITLE & NUMBER:
 FLOW LINES
 GRADING PLAN

BP-03.03

Date: Jan 05, 2024, 2:42pm User ID: Mitch
 File: C:\Users\Mitch\actionsportsdesign.com\PROJECTS - Documents\TX-San Antonio-OP Schnabel Bike Park-23-050-BP\04-Construction Documents\Sheet Files\BP-FLOW LINES-LAYOUT PLAN.dwg

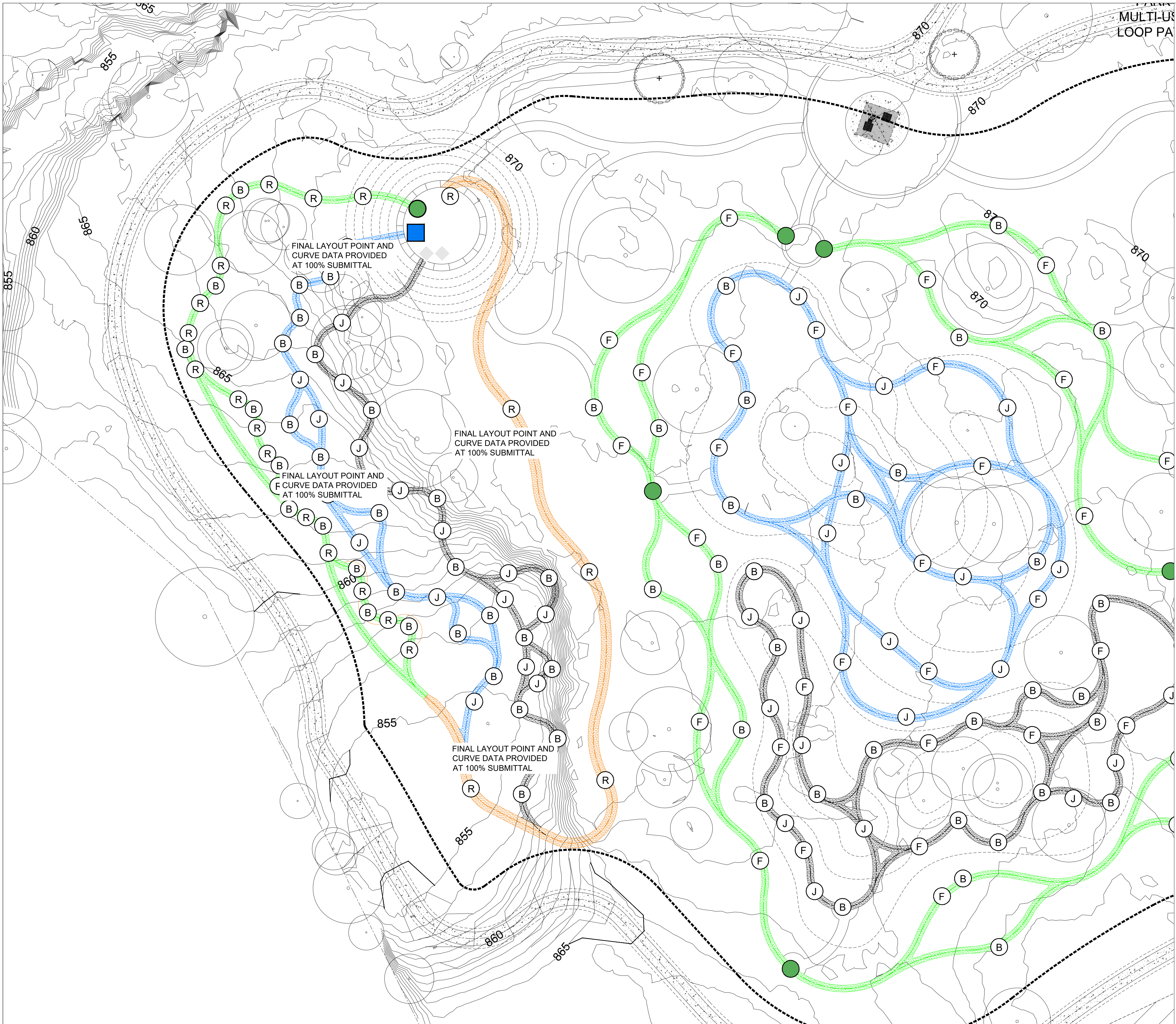

FLOW LINES-LAYOUT PLAN

FLOW LINES LAYOUT - NOTES

1. COORDINATE VALUES SHOWN ARE INTENDED FOR HORIZONTAL POSITIONING AND DIMENSION CLARIFICATION ONLY. ALL POINTS SET IN THE FIELD FROM THESE VALUES SHALL FIRST BE CHECKED BY THE CONTRACTOR TO ENSURE THAT THE LOCATION IS CONSISTENT WITH THE DIMENSIONS AND GRAPHIC LOCATIONS SHOWN ON THE APPROVED CONSTRUCTION PLANS. IN THE CASE OF A DISCREPANCY WITH ANY COORDINATE VALUE SHOWN, THE CONTRACTOR SHALL BE RESPONSIBLE TO NOTIFY THE CITY PRIOR TO COMMENCING ANY CONSTRUCTION ACTIVITY THAT MAY BE AFFECTED.
2. ALL COORDINATES SHOWN AT THE BOTTOM OF ALL BANKS/ TRANSITIONS NEED TO BE CHECKED AGAINST THE CROSS SECTIONS FOR ACCURACY.
3. BECAUSE OF THE SCALE OF THIS DRAWING AND PROXIMITY OF FEATURES TO EACH OTHER, THE LOCATION OF SOME OR THE POINTS MAY BE OBSCURED. REFER TO THE LAYOUT DATA FOR THE ACTUAL LOCATIONS FOR ALL POINTS.
4. CONTRACTOR TO BE RESPONSIBLE FOR SURVEY WORK.

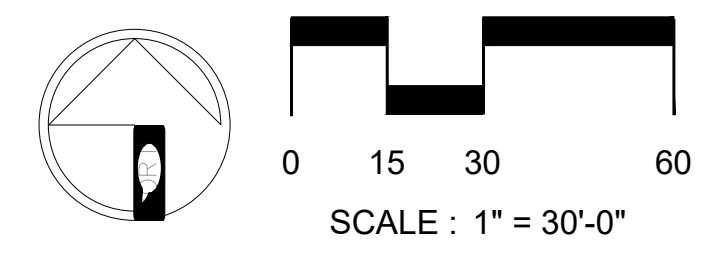

ISSUED SETS	
Date	Description
01/05/2024	DD SUBMITTAL For Review Only

REVISIONS		
No.	Date	Description

LANDSCAPE ARCHITECT
BENDER WELLS CLARK DESIGN
 830 N. ALAMO ST.
 SAN ANTONIO, TEXAS 78215

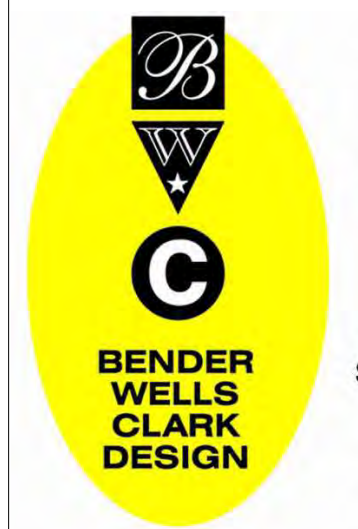

Landscape Architecture
Urban Design
Planning
 830 North Alamo Street
 San Antonio, Texas 78215
 210-692-9221
 www.bwcdesign.com

© 2023 Bender Wells Clark Design
 All rights reserved. No part of this document may be reproduced or utilized in any form without prior written authorization of Bender Wells Clark Design.

**O. P. Schnabel Bike Park
 Bike Park
 2022 Bond Improvements**

**9700 Rochelle Road
 San Antonio Tx 78240**

This drawing and the design were prepared specifically for this site and client and does not apply to any other projects. The reuse of this design for any other project is prohibited. Use of this set of drawings requires appropriate authorization from Bender Wells Clark Design.

LANDSCAPE ARCHITECT'S LICENSURE

THESE DOCUMENTS ARE INCOMPLETE AND ARE RELEASED FOR INTERIM REVIEW ONLY, AND NOT INTENDED FOR REGULATORY APPROVAL, BIDDING, PERMIT, OR CONSTRUCTION PURPOSES.

Drawn By : MM/ MJ Checked By : MM

SHEET TITLE & NUMBER:

FLOW LINES LAYOUT PLAN

BP-03.04

Date: Jan 05, 2024, 2:42pm User ID: Mitch
 File: C:\Users\Mitch\actionsportsdesign.com\PROJECTS - Documents\TX-San Antonio-OP Schnabel Bike Park-23-050-BP\04-Construction Documents\Sheet Files\FLOW LINES-LAYOUT PLAN.dwg

Point Table			Point Table			Parcel Line Table			Curve Table			
Point #	Northing	Easting	Point #	Northing	Easting	Line #	Length	Direction	Curve #	Length	Radius	Delta
1	589818.3093	3047210.3013	27	589643.5703	3047040.2456	L1	4.17	N37° 43' 09.78"E	C1	47.12	15.00	180.00
2	589811.6983	3047205.1882	28	589638.7365	3047047.9574	L2	4.25	N52° 16' 39.91"W	C2	196.63	47.75	235.96
3	589813.5291	3047225.4879	29	589624.2411	3047032.6259	L3	48.27	N52° 16' 50.19"W	C3	138.29	42.11	188.17
4	589799.3431	3047214.5952	30	589740.5682	3047213.7514	L4	33.00	S37° 43' 08.76"W	C4	20.94	10.00	119.99
5	589804.7699	3047249.8640	31	589739.4506	3047210.8453	L5	6.40	N37° 43' 09.81"E	C5	15.71	6.00	150.00
6	589779.5748	3047229.6465	32	589717.7623	3047221.2274	L6	24.27	N52° 16' 50.19"W	C6	39.38	16.25	138.83
7	589771.0267	3047145.5165	33	589750.0421	3047267.8306	L7	97.65	N52° 16' 52.31"W	C7	103.35	38.59	153.45
8	589748.8113	3047154.5981	34	589796.0605	3047272.7378	L8	54.65	N52° 16' 52.31"W	C8	149.83	40.89	209.97
9	589783.1593	3047155.671							C9	47.12	15.00	180.00
10	589740.2614	3047173.521							C10	122.52	39.00	180.00
11	589814.0366	3047088.091							C11	175.25	43.41	231.31
12	589803.3953	3047109.521							C12	169.65	54.00	180.00
13	589785.1858	3047108.8730	39	589716.6077	3047311.0604	L13	48.67	N37° 43' 07.69"E	C13	24.01	10.00	137.56
14	589748.3188	3047018.9345	40	589695.0278	3047294.3699	L14	55.83	N37° 43' 07.69"E	C14	6.62	10.00	37.91
15	589761.8408	3047006.0988	41	589688.9092	3047302.2811	L15	24.50	N52° 16' 52.31"W	C15	9.29	10.00	53.22
16	589778.7543	3047014.0839	42	589716.4022	3047365.2664	L16	55.83	N37° 43' 13.84"E	C16	22.92	10.00	131.30
17	589783.4095	3047018.6153	43	589677.9051	3047335.4923	L17	33.00	S52° 16' 52.31"E	C17	15.71	10.00	90.00
18	589814.0045	3047079.1378	44	589698.0958	3047309.3866	L18	146.97	N37° 43' 09.81"E				
19	589724.1772	3046991.6774	45	589695.4966	3047312.7469	L19	146.97	N37° 43' 09.81"E				
20	589724.4904	3047012.3016	46	589680.5059	3047332.1294	L20	160.74	N37° 43' 05.39"E				
21	589718.1356	3047016.4869	47	589713.3121	3047308.5115	L21	156.07	N37° 42' 54.69"E				
22	589714.0833	3047006.6011	48	589682.2584	3047261.1046	L22	62.05	S52° 16' 50.19"E				
23	589691.8753	3047015.7008	49	589673.5136	3047254.3415	L23	139.05	S67° 42' 38.60"W				
24	589681.4638	3047030.2716	50	589693.2507	3047239.2556	L24	122.43	N37° 42' 56.09"E				
25	589664.1153	3047027.0754	51	589696.1304	3047220.6060	L25	200.40	N37° 42' 56.09"E				
26	589641.9073	3047036.1751	52	589679.9587	3047210.0147							

FINAL LAYOUT POINT AND CURVE DATA PROVIDED AT 100% SUBMITTAL

FLOW LINES LAYOUT - NOTES

- COORDINATE VALUES SHOWN ARE INTENDED FOR HORIZONTAL POSITIONING AND DIMENSION CLARIFICATION ONLY. ALL POINTS SET IN THE FIELD FROM THESE VALUES SHALL FIRST BE CHECKED BY THE CONTRACTOR TO ENSURE THAT THE LOCATION IS CONSISTENT WITH THE DIMENSIONS AND GRAPHIC LOCATIONS SHOWN ON THE APPROVED CONSTRUCTION PLANS. IN THE CASE OF A DISCREPANCY WITH ANY COORDINATE VALUE SHOWN, THE CONTRACTOR SHALL BE RESPONSIBLE TO NOTIFY THE CITY PRIOR TO COMMENCING ANY CONSTRUCTION ACTIVITY THAT MAY BE AFFECTED.
- ALL COORDINATES SHOWN AT THE BOTTOM OF ALL BANKS/ TRANSITIONS NEED TO BE CHECKED AGAINST THE CROSS SECTIONS FOR ACCURACY.
- BECAUSE OF THE SCALE OF THIS DRAWING AND PROXIMITY OF FEATURES TO EACH OTHER, THE LOCATION OF SOME OR THE POINTS MAY BE OBSCURED. REFER TO THE LAYOUT DATA FOR THE ACTUAL LOCATIONS FOR ALL POINTS.
- CONTRACTOR TO BE RESPONSIBLE FOR SURVEY WORK.

ISSUED SETS	
Date	Description
01/05/2024	DD SUBMITTAL For Review Only

REVISIONS		
No.	Date	Description

LANDSCAPE ARCHITECT
BENDER WELLS CLARK DESIGN
 830 N. ALAMO ST.
 SAN ANTONIO, TEXAS 78215



© 2023 Bender Wells Clark Design
 All rights reserved. No part of this document may be reproduced or utilized in any form without prior written authorization of Bender Wells Clark Design.

**O. P. Schnabel Bike Park
 Bike Park
 2022 Bond Improvements**

**9700 Rochelle Road
 San Antonio Tx 78240**

This drawing and the design were prepared specifically for this site and client and does not apply to any other projects. The reuse of this drawing for any other projects is prohibited. Use of this set of drawings requires appropriate authorization from Bender Wells Clark Design.

LANDSCAPE ARCHITECT'S LICENSURE

THESE DOCUMENTS ARE INCOMPLETE AND ARE RELEASED FOR INTERIM REVIEW ONLY, AND NOT INTENDED FOR REGULATORY APPROVAL, BIDDING, PERMIT, OR CONSTRUCTION PURPOSES.

Drawn By : MM/ MJ Checked By : MM

SHEET TITLE & NUMBER:
 FLOW LINES LAYOUT TABLE

BP-03.05

Date: Jan 05, 2024, 2:43pm User ID: Mitch
 File: C:\Users\Mitch\actionsportsdesign.com\PROJECTS - Documents\TX-San Antonio-OP Schnabel Bike Park-23-050-BP-04-Construction Documents\Sheet Files\BP-SKILLS COURSE-REFERENCE PLAN.dwg



SKILLS COURSE FEATURE LEGEND

SYMBOL	DESCRIPTION
RD-01	ROCK DROP-1.5'- SEE (1-BP-06.01)
RD-02	ROCK DROP-2.0'-SEE (2-BP-06.01)
RZ-01	ROCK ZIG ZAG-SEE (2-BP-06.01)
RR-01	ROCK ROLLER 2.0'-SEE (3-BP-06.01)
BR-01	BOULDER RIDGE-1.5'-SEE (4-BP-06.01)
RG-01	ROCK GARDEN-DRAINAGE-SEE (5-BP-06.01)
RA-01	ROCK ARMORING-TYPE 2-SEE (2-BP-06.04)
BP-01	BOULDER PLACEMENT-2.0'-SEE (6-BP-06.01)
RD-04	ROLLER-DOUBLE-3.0'-SEE (4-BP-05.02)
JD-03	JUMP-DOUBLE-3.0' to 4.0'-SEE (1-BP-05.03)
JD-04	JUMP-DOUBLE-4.0' to 5.0'-SEE (2-BP-05.03)
JT-03	JUMP-TABLE-3.0' to 4.0'-SEE (3-BP-05.03)
JT-04	JUMP-TABLE-4.0' to 5.0'-SEE (4-BP-05.03)
B-03	BERM-3.0'-CHIP SEAL-SEE (3-BP-06.02)
B-04	BERM-4.0'-CHIP SEAL-SEE (3-BP-06.02)
TC-01	CHIP SEAL TRAIL CONSTRUCTION-SEE (7-BP-06.03)

SKILLS COURSE - NOTES

1. THE LOCATIONS OF UNDERGROUND UTILITIES SHOWN ARE BASED ON THE SURVEY PROVIDED. THE CONTRACTOR SHALL NOTIFY THE STATE 811 DIG ALERT, PROPER LOCAL AUTHORITIES AND RESPECTIVE UTILITY COMPANIES TO CONFIRM THE LOCATION OF ALL EXISTING UTILITIES BEFORE COMMENCING WORK. ANY DAMAGE DUE TO FAILURE OF THE CONTRACTOR TO CONTACT THE PROPER AUTHORITIES SHALL BE BORNE BY THE CONTRACTOR.
2. CONTRACTOR(S) SHALL THOROUGHLY FAMILIARIZE THEMSELVES WITH ALL CONSTRUCTION DOCUMENTS AND SITE CONDITIONS PRIOR TO BIDDING AND PRIOR TO CONSTRUCTION.
3. ANY DISCREPANCIES BETWEEN DRAWINGS AND SITE CONDITIONS SHALL BE REPORTED IMMEDIATELY TO THE TRACK DESIGNER FOR CLARIFICATION AND RESOLUTION PRIOR TO BIDDING OR CONSTRUCTION.

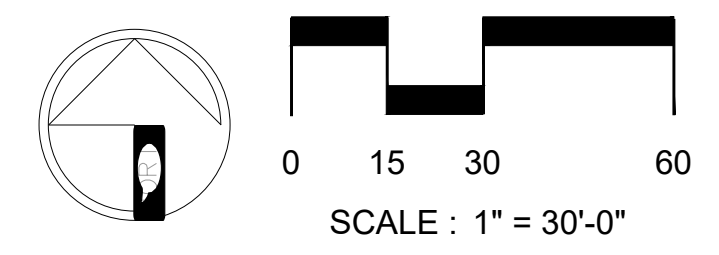

SKILLS COURSE-REFERENCE PLAN

ISSUED SETS

Date	Description
01/05/2024	DD SUBMITTAL For Review Only

REVISIONS

No.	Date	Description
-----	------	-------------

LANDSCAPE ARCHITECT
BENDER WELLS CLARK DESIGN
 830 N. ALAMO ST.
 SAN ANTONIO, TEXAS 78215



© 2023 Bender Wells Clark Design
 All rights reserved. No part of this document may be reproduced or utilized in any form without prior written authorization of Bender Wells Clark Design.

**O. P. Schnabel Bike Park
 Bike Park
 2022 Bond Improvements**

**9700 Rochelle Road
 San Antonio Tx 78240**

This drawing and the design were prepared specifically for this site and client and does not apply to any other projects. The use of this drawing for any other purpose is prohibited. Use of this set of drawings requires appropriate authorization from Bender Wells Clark Design.

LANDSCAPE ARCHITECT'S LICENSURE

THESE DOCUMENTS ARE INCOMPLETE AND ARE RELEASED FOR INTERIM REVIEW ONLY, AND NOT INTENDED FOR REGULATORY APPROVAL, BIDDING, PERMIT, OR CONSTRUCTION PURPOSES.

Drawn By : MM/ MJ Checked By : MM

SHEET TITLE & NUMBER:
 SKILLS COURSE
 REFERENCE PLAN

BP-04.01

Date: Jan 05, 2024, 2:44pm User ID: Mitch
 File: C:\Users\Mitch\actionsportsdesign.com\PROJECTS - Documents\TX-San Antonio-OP Schnabel Bike Park-23-050-BP-04-Construction Documents\Sheet Files\BP-SKILLS COURSE-MATERIALS PLAN.dwg



FLOW LINES-REFERENCE PLAN

SKILLS COURSE MATERIALS - LEGEND

- SHOTCRETE FLOW LINE ACRYLIC SURFACE-TAN
- POURED IN PLACE CONCRETE ACRYLIC SURFACE-TAN
- SEEDED GRASS BACK OF BERMS-SIDE OF JUMPS

SKILLS COURSE MATERIALS - NOTES

1. THE LOCATIONS OF UNDERGROUND UTILITIES SHOWN ARE BASED ON THE SURVEY PROVIDED. THE CONTRACTOR SHALL NOTIFY THE STATE 811 DIG ALERT, PROPER LOCAL AUTHORITIES AND RESPECTIVE UTILITY COMPANIES TO CONFIRM THE LOCATION OF ALL EXISTING UTILITIES BEFORE COMMENCING WORK. ANY DAMAGE DUE TO FAILURE OF THE CONTRACTOR TO CONTACT THE PROPER AUTHORITIES SHALL BE BORNE BY THE CONTRACTOR.
2. CONTRACTOR(S) SHALL THOROUGHLY FAMILIARIZE THEMSELVES WITH ALL CONSTRUCTION DOCUMENTS AND SITE CONDITIONS PRIOR TO BIDDING AND PRIOR TO CONSTRUCTION.
3. ANY DISCREPANCIES BETWEEN DRAWINGS AND SITE CONDITIONS SHALL BE REPORTED IMMEDIATELY TO THE BIKE PARK DESIGNER FOR CLARIFICATION AND RESOLUTION PRIOR TO BIDDING OR CONSTRUCTION.

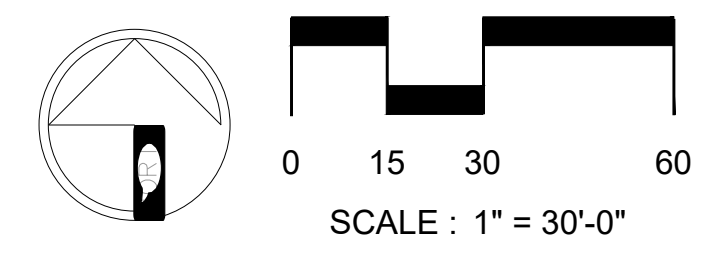

ISSUED SETS	
Date	Description
01/05/2024	DD SUBMITTAL For Review Only

REVISIONS		
No.	Date	Description

LANDSCAPE ARCHITECT
BENDER WELLS CLARK DESIGN
 830 N. ALAMO ST.
 SAN ANTONIO, TEXAS 78215

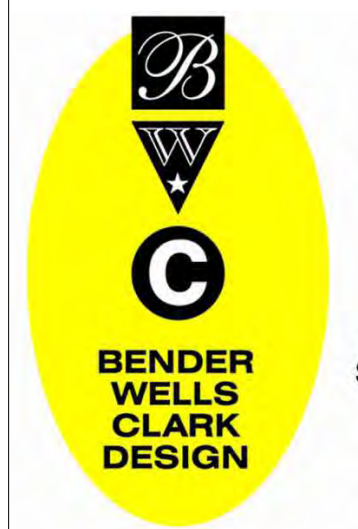

Landscape Architecture
Urban Design
Planning
 830 North Alamo Street
 San Antonio, Texas 78215
 210-692-9221
 www.bwcdesign.com

© 2023 Bender Wells Clark Design
 All rights reserved. No part of this document may be reproduced or utilized in any form without prior written authorization of Bender Wells Clark Design.

**O. P. Schnabel Bike Park
 Bike Park
 2022 Bond Improvements**

**9700 Rochelle Road
 San Antonio Tx 78240**

This drawing and the design were prepared specifically for this site and client and does not apply to any other projects. The reuse of this drawing for any other project is prohibited. Use of this set of drawings requires appropriate authorization from Bender Wells Clark Design.

LANDSCAPE ARCHITECT'S LICENSURE

THESE DOCUMENTS ARE INCOMPLETE AND ARE RELEASED FOR INTERIM REVIEW ONLY, AND NOT INTENDED FOR REGULATORY APPROVAL, BIDDING, PERMIT, OR CONSTRUCTION PURPOSES.

Drawn By : MM/ MJ Checked By : MM

SHEET TITLE & NUMBER:

SKILLS COURSE MATERIALS PLAN

BP-04.02

Date: Jan 05, 2024, 2:51pm User ID: Mitch
 File: C:\Users\Mitch\actionsportsdesign.com\PROJECTS - Documents\TX-San Antonio-OP Schnabel Bike Park-23-050-BP-04-Construction Documents\Sheet Files\BP-SKILLS COURSE-GRADING PLAN.dwg



GRADING & DRAINAGE LEGEND

SYMBOL	DESCRIPTION
—>	DIRECTION OF SURFACE FLOW
----	G.B. BREAK IN GRADE
---	F.L. FLOWLINE IN SWALE
TJ	TOP OF JUMP ELEVATION
TF	TOP OF FLOW LINE ELEVATION
+	DRAIN INLET

GRADING & DRAINAGE NOTES

1. FINAL HEIGHT AND SHAPE OF EXCAVATION TO BE VERIFIED BY BIKE PARK DESIGNER IN THE FIELD.
2. ALL SPOT ELEVATIONS ARE FOR TOP OF FINISH WORK UNLESS OTHERWISE NOTED.
3. MINIMUM SLOPE FOR ALL CONCRETE FINISH WORK SHALL BE 1%. WATER MUST DRAIN TOWARDS DIRECTION OF FLOW ARROWS AND FOLLOW OVERALL DESIGN INTENT.
4. MAXIMUM SIDEWALK CROSS SLOPE IS 2.0%.
5. MAXIMUM SIDEWALK LONGITUDINAL SLOPE IS 5.0%.
6. ALL AREAS DISTURBED BY GRADING OPERATIONS TO BE FINE GRADED.
7. VERIFY LOCATION AND DEPTH OF ALL UTILITIES PRIOR TO COMMENCING WORK.
8. REFER TO SECTIONS AND PROFILES FOR HEIGHT, RADII AND PROFILES.
9. ALL FINE GRADING OF EARTHWORK SHALL BE INSPECTED WITH TEMPLATES CUT TO THE SPECIFIED RADI/ ANGLE. CONTRACTOR TO PROVIDE SHOP DRAWINGS FOR ALL TEMPLATES/ SCREEDS TO BE USED FOR EARTHWORK TOLERANCES FOR APPROVAL BY BIKE PARK DESIGNER.
10. CONTRACTOR TO PROTECT ALL EXCAVATIONS FROM SOIL EROSION AND WATER SATURATION AT ALL TIMES USING APPROPRIATE CONSTRUCTION METHODS. AND LOSS OF SOIL PROFILE DURING CONSTRUCTION SHALL BE REPLACED WITH APPROPRIATE SOIL COMPOSITION AND COMPACTION METHODS TO MATCH LOSS SOIL.
11. CONTRACTOR TO VERIFY FEATURE ELEVATIONS WITH FLOW LINE DETAIL SECTIONS. IF A DISCREPANCY OCCURS, CONTRACTOR SHALL CONTACT BIKE PARK DESIGNER IMMEDIATELY.
12. CONTRACTOR TO REFER TO CIVIL PLANS FOR FINISH GRADE ELEVATIONS BEYOND FLOW LINES FOOTPRINT.

SURVEY NOTES

1. LOCATE ALL SURVEY MARKS INCLUDING BENCH MARKS AND PROPERTY LINES IN ORDER THAT THE EXACT LINES OF CONSTRUCTION LIMITS AND GRADES MAY BE DETERMINED. BRING ANY DISCREPANCIES TO THE OWNER'S REPRESENTATIVE IMMEDIATELY BEFORE PROCEEDING WITH WORK.
2. VERIFY ENTIRE LAYOUT PRIOR TO START OF CONSTRUCTION WITH PROJECT OWNER'S REPRESENTATIVES AND SKATE PARK DESIGNER.
3. LOCATE AND PROTECT CONTROL POINTS PRIOR TO STARTING SITE WORK AND PROTECT ALL PERMANENT REFERENCE POINTS DURING ENTIRE CONSTRUCTION. REPLACE PROJECT CONTROL POINTS WHICH MAY BE LOST OR DESTROYED DURING CONSTRUCTION.
4. CONTRACTOR SHALL VERIFY FINISH GRADE ELEVATIONS AS SHOWN ON CIVIL ENGINEER'S PLANS AND BRING ANY DISCREPANCIES TO THE OWNER'S REPRESENTATIVE IMMEDIATELY BEFORE PROCEEDING WITH WORK.

SPOT ELEVATION LEGEND

BW	BOTTOM OF WALL
TW	TOP OF WALL
BB	BOTTOM OF BANK
TB	TOP OF BANK
ES	EDGE OF SLAB
TS	TOP OF SLAB
TL	TOP OF LEDGE
BL	BOTTOM OF LEDGE
TC	TOP OF CURB
BC	BOTTOM OF CURB
TT	TOP OF TRANSITION
BT	BOTTOM OF TRANSITION
RIM	RIM OF DRAIN
INV	INVERT

ISSUED SETS

Date	Description
01/05/2024	DD SUBMITTAL For Review Only

REVISIONS

No.	Date	Description
-----	------	-------------

LANDSCAPE ARCHITECT
BENDER WELLS CLARK DESIGN
 830 N. ALAMO ST.
 SAN ANTONIO, TEXAS 78215

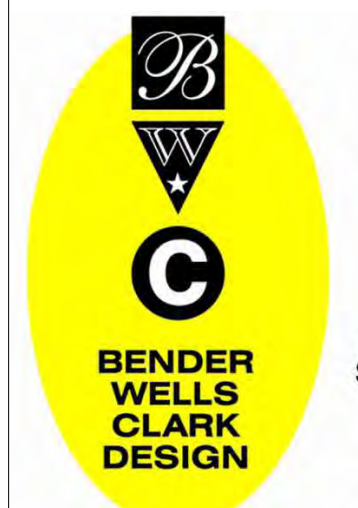

Landscape Architecture
Urban Design
Planning
 830 North Alamo Street
 San Antonio, Texas 78215
 210-692-9221
 www.bwcdesign.com

© 2023 Bender Wells Clark Design
 All rights reserved. No part of this document may be reproduced or utilized in any form without prior written authorization of Bender Wells Clark Design.

O. P. Schnabel Bike Park
Bike Park
2022 Bond Improvements
9700 Rochelle Road
San Antonio Tx 78240

This drawing and the design were prepared specifically for this site and client and does not apply to any other projects. The reuse of this drawing for any other project is prohibited. Use of this set of drawings requires appropriate authorization from Bender Wells Clark Design.

LANDSCAPE ARCHITECT'S LICENSURE

THESE DOCUMENTS ARE INCOMPLETE AND ARE RELEASED FOR INTERIM REVIEW ONLY, AND NOT INTENDED FOR REGULATORY APPROVAL, BIDDING, PERMIT, OR CONSTRUCTION PURPOSES.

Drawn By : MM/ MJ Checked By : MM

SHEET TITLE & NUMBER:

SKILLS COURSE GRADING PLAN

BP-04.03

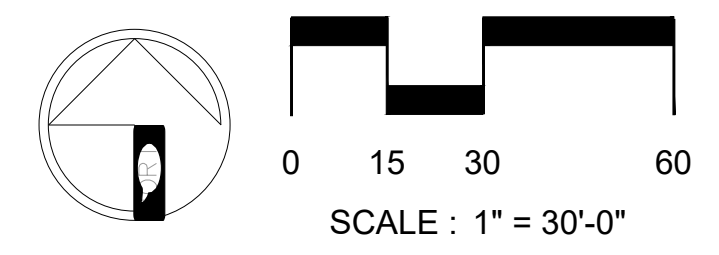

SKILLS COURSE-GRADING PLAN

Date: Jan 05, 2024, 2:45pm User ID: Mitch
 File: C:\Users\Mitch\actionsportsdesign.com\PROJECTS - Documents\TX-San Antonio-OP Schnabel Bike Park-23-050-BP-04-Construction Documents\Sheet Files\BP-04-Skills Course-LAYOUT PLAN.dwg



SKILLS COURSE-LAYOUT PLAN

SKILLS COURSE LAYOUT - NOTES

- COORDINATE VALUES SHOWN ARE INTENDED FOR HORIZONTAL POSITIONING AND DIMENSION CLARIFICATION ONLY. ALL POINTS SET IN THE FIELD FROM THESE VALUES SHALL FIRST BE CHECKED BY THE CONTRACTOR TO ENSURE THAT THE LOCATION IS CONSISTENT WITH THE DIMENSIONS AND GRAPHIC LOCATIONS SHOWN ON THE APPROVED CONSTRUCTION PLANS. IN THE CASE OF A DISCREPANCY WITH ANY COORDINATE VALUE SHOWN, THE CONTRACTOR SHALL BE RESPONSIBLE TO NOTIFY THE CITY PRIOR TO COMMENCING ANY CONSTRUCTION ACTIVITY THAT MAY BE AFFECTED.
- ALL COORDINATES SHOWN AT THE BOTTOM OF ALL BANKS/ TRANSITIONS NEED TO BE CHECKED AGAINST THE CROSS SECTIONS FOR ACCURACY.
- BECAUSE OF THE SCALE OF THIS DRAWING AND PROXIMITY OF FEATURES TO EACH OTHER, THE LOCATION OF SOME OR THE POINTS MAY BE OBSCURED. REFER TO THE LAYOUT DATA FOR THE ACTUAL LOCATIONS FOR ALL POINTS.
- CONTRACTOR TO BE RESPONSIBLE FOR SURVEY WORK.

ISSUED SETS	
Date	Description
01/05/2024	DD SUBMITTAL For Review Only

REVISIONS		
No.	Date	Description

LANDSCAPE ARCHITECT
BENDER WELLS CLARK DESIGN
 830 N. ALAMO ST.
 SAN ANTONIO, TEXAS 78215

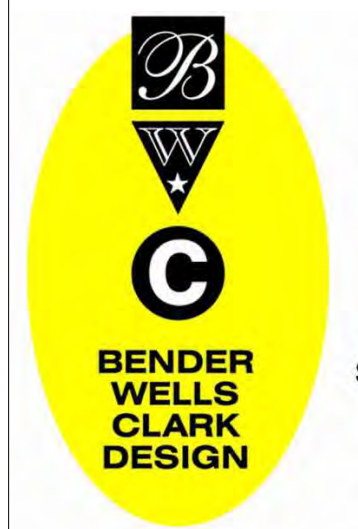

Landscape Architecture
Urban Design
Planning
 830 North Alamo Street
 San Antonio, Texas 78215
 210-692-9221
 www.bwcdesign.com

© 2023 Bender Wells Clark Design
 All rights reserved. No part of this document may be reproduced or utilized in any form without prior written authorization of Bender Wells Clark Design.

**O. P. Schnabel Bike Park
 Bike Park
 2022 Bond Improvements**

**9700 Rochelle Road
 San Antonio Tx 78240**

This drawing and the design were prepared specifically for this site and client and does not apply to any other projects. The reuse of this drawing for any other project is prohibited. Use of this set of drawings requires appropriate authorization from Bender Wells Clark Design.

LANDSCAPE ARCHITECT'S LICENSURE

THESE DOCUMENTS ARE INCOMPLETE AND ARE RELEASED FOR INTERIM REVIEW ONLY, AND NOT INTENDED FOR REGULATORY APPROVAL, BIDDING, PERMIT, OR CONSTRUCTION PURPOSES.

Drawn By : MM/ MJ Checked By : MM

SHEET TITLE & NUMBER:
 SKILLS COURSE LAYOUT PLAN

BP-04.04

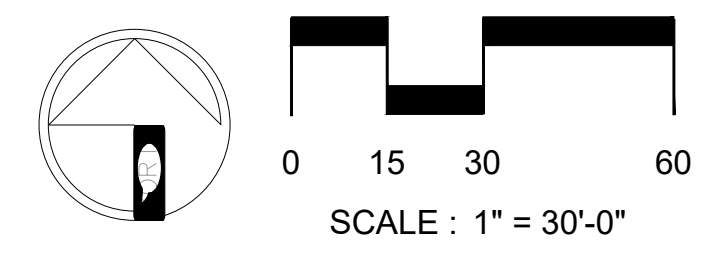

Point Table			Point Table			Parcel Line Table			Curve Table			
Point #	Northing	Easting	Point #	Northing	Easting	Line #	Length	Direction	Curve #	Length	Radius	Delta
1	589818.3093	3047210.3013	27	589643.5703	3047040.2456	L1	4.17	N37° 43' 09.78"E	C1	47.12	15.00	180.00
2	589811.6983	3047205.1882	28	589638.7365	3047047.9574	L2	4.25	N52° 16' 39.91"W	C2	196.63	47.75	235.96
3	589813.5291	3047225.4879	29	589624.2411	3047032.6259	L3	48.27	N52° 16' 50.19"W	C3	138.29	42.11	188.17
4	589799.3431	3047214.5952	30	589740.5682	3047213.7514	L4	33.00	S37° 43' 08.76"W	C4	20.94	10.00	119.99
5	589804.7699	3047249.8640	31	589739.4506	3047210.8453	L5	6.40	N37° 43' 09.81"E	C5	15.71	6.00	150.00
6	589779.5748	3047229.6465	32	589717.7623	3047221.2274	L6	24.27	N52° 16' 50.19"W	C6	39.38	16.25	138.83
7	589771.0267	3047145.5165	33	589750.0421	3047267.8306	L7	97.65	N52° 16' 52.31"W	C7	103.35	38.59	153.45
8	589748.8113	3047154.5981	34	589796.0605	3047272.7378	L8	54.65	N52° 16' 52.31"W	C8	149.83	40.89	209.97
9	589783.1593	3047155.671							C9	47.12	15.00	180.00
10	589740.2614	3047173.521							C10	122.52	39.00	180.00
11	589814.0366	3047088.091							C11	175.25	43.41	231.31
12	589803.3953	3047109.521							C12	169.65	54.00	180.00
13	589785.1858	3047108.8730	39	589716.6077	3047311.0604	L13	48.67	N37° 43' 07.69"E	C13	24.01	10.00	137.56
14	589748.3188	3047018.9345	40	589695.0278	3047294.3699	L14	55.83	N37° 43' 07.69"E	C14	6.62	10.00	37.91
15	589761.8408	3047006.0988	41	589688.9092	3047302.2811	L15	24.50	N52° 16' 52.31"W	C15	9.29	10.00	53.22
16	589778.7543	3047014.0839	42	589716.4022	3047365.2664	L16	55.83	N37° 43' 13.84"E	C16	22.92	10.00	131.30
17	589783.4095	3047018.6153	43	589677.9051	3047335.4923	L17	33.00	S52° 16' 52.31"E	C17	15.71	10.00	90.00
18	589814.0045	3047079.1378	44	589698.0958	3047309.3866	L18	146.97	N37° 43' 09.81"E				
19	589724.1772	3046991.6774	45	589695.4966	3047312.7469	L19	146.97	N37° 43' 09.81"E				
20	589724.4904	3047012.3016	46	589680.5059	3047332.1294	L20	160.74	N37° 43' 05.39"E				
21	589718.1356	3047016.4869	47	589713.3121	3047308.5115	L21	156.07	N37° 42' 54.69"E				
22	589714.0833	3047006.6011	48	589682.2584	3047261.1046	L22	62.05	S52° 16' 50.19"E				
23	589691.8753	3047015.7008	49	589673.5136	3047254.3415	L23	139.05	S67° 42' 38.60"W				
24	589681.4638	3047030.2716	50	589693.2507	3047239.2556	L24	122.43	N37° 42' 56.09"E				
25	589664.1153	3047027.0754	51	589696.1304	3047220.6060	L25	200.40	N37° 42' 56.09"E				
26	589641.9073	3047036.1751	52	589679.9587	3047210.0147							

FINAL LAYOUT POINT AND CURVE DATA PROVIDED AT 100% SUBMITTAL

SKILLS COURSE LAYOUT - NOTES

- COORDINATE VALUES SHOWN ARE INTENDED FOR HORIZONTAL POSITIONING AND DIMENSION CLARIFICATION ONLY. ALL POINTS SET IN THE FIELD FROM THESE VALUES SHALL FIRST BE CHECKED BY THE CONTRACTOR TO ENSURE THAT THE LOCATION IS CONSISTENT WITH THE DIMENSIONS AND GRAPHIC LOCATIONS SHOWN ON THE APPROVED CONSTRUCTION PLANS. IN THE CASE OF A DISCREPANCY WITH ANY COORDINATE VALUE SHOWN, THE CONTRACTOR SHALL BE RESPONSIBLE TO NOTIFY THE CITY PRIOR TO COMMENCING ANY CONSTRUCTION ACTIVITY THAT MAY BE AFFECTED.
- ALL COORDINATES SHOWN AT THE BOTTOM OF ALL BANKS/ TRANSITIONS NEED TO BE CHECKED AGAINST THE CROSS SECTIONS FOR ACCURACY.
- BECAUSE OF THE SCALE OF THIS DRAWING AND PROXIMITY OF FEATURES TO EACH OTHER, THE LOCATION OF SOME OR THE POINTS MAY BE OBSCURED. REFER TO THE LAYOUT DATA FOR THE ACTUAL LOCATIONS FOR ALL POINTS.
- CONTRACTOR TO BE RESPONSIBLE FOR SURVEY WORK.

ISSUED SETS	
Date	Description
01/05/2024	DD SUBMITTAL For Review Only

REVISIONS		
No.	Date	Description

LANDSCAPE ARCHITECT
BENDER WELLS CLARK DESIGN
 830 N. ALAMO ST.
 SAN ANTONIO, TEXAS 78215

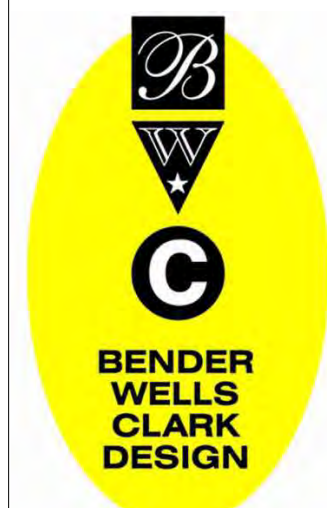

Landscape Architecture
Urban Design
Planning
 830 North Alamo Street
 San Antonio, Texas 78215
 210-692-9221
 www.bwcdesign.com

© 2023 Bender Wells Clark Design
 All rights reserved. No part of this document may be reproduced or utilized in any form without prior written authorization of Bender Wells Clark Design.

**O. P. Schnabel Bike Park
 Bike Park
 2022 Bond Improvements**

**9700 Rochelle Road
 San Antonio Tx 78240**

This drawing and the design were prepared specifically for this site and client and does not apply to any other projects. The reuse of this drawing for any other project is prohibited. Use of this set of drawings requires appropriate authorization from Bender Wells Clark Design.

LANDSCAPE ARCHITECT'S LICENSURE

THESE DOCUMENTS ARE INCOMPLETE AND ARE RELEASED FOR INTERIM REVIEW ONLY, AND NOT INTENDED FOR REGULATORY APPROVAL, BIDDING, PERMIT, OR CONSTRUCTION PURPOSES.

Drawn By : MM/ MJ Checked By : MM

SHEET TITLE & NUMBER:
 SKILLS COURSE LAYOUT TABLE

BP-04.05

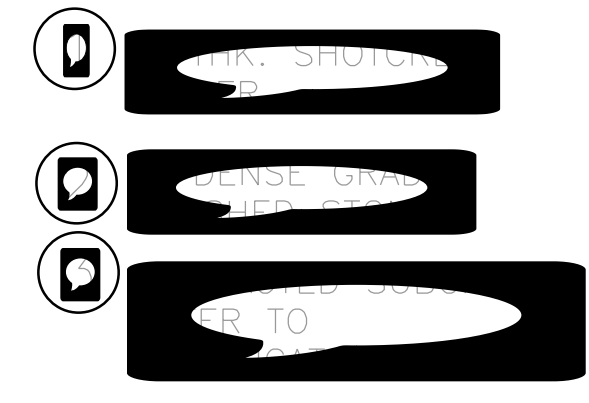
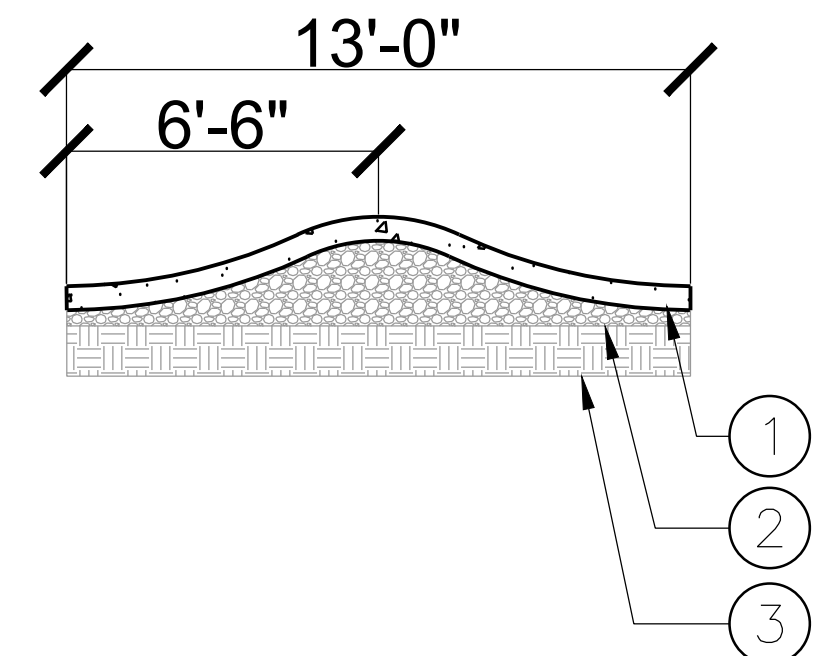
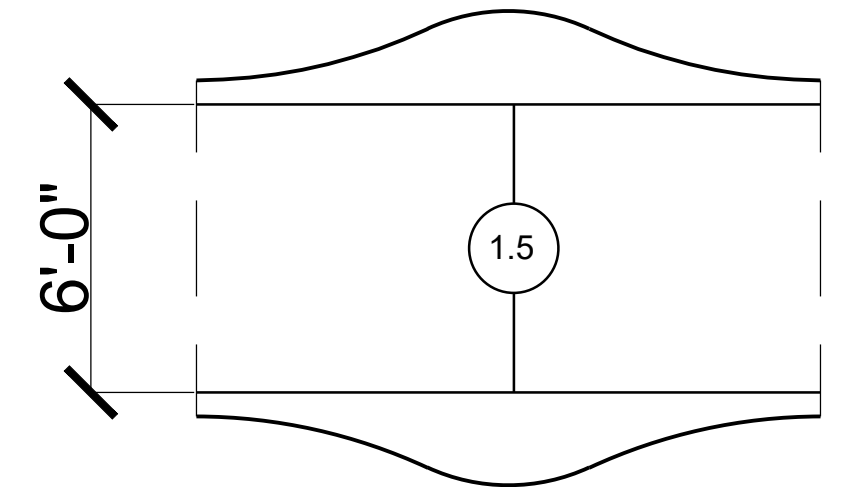

1 ROLLER-SINGLE-1.5'

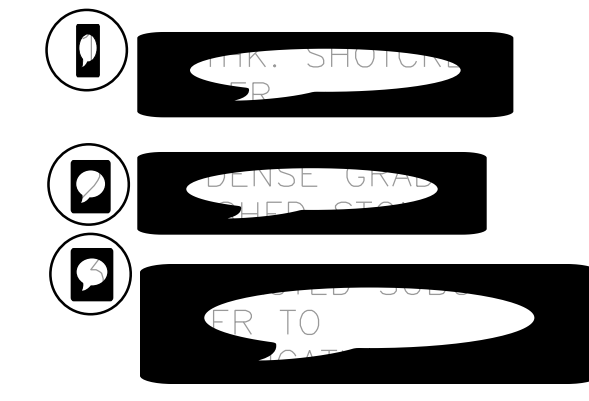
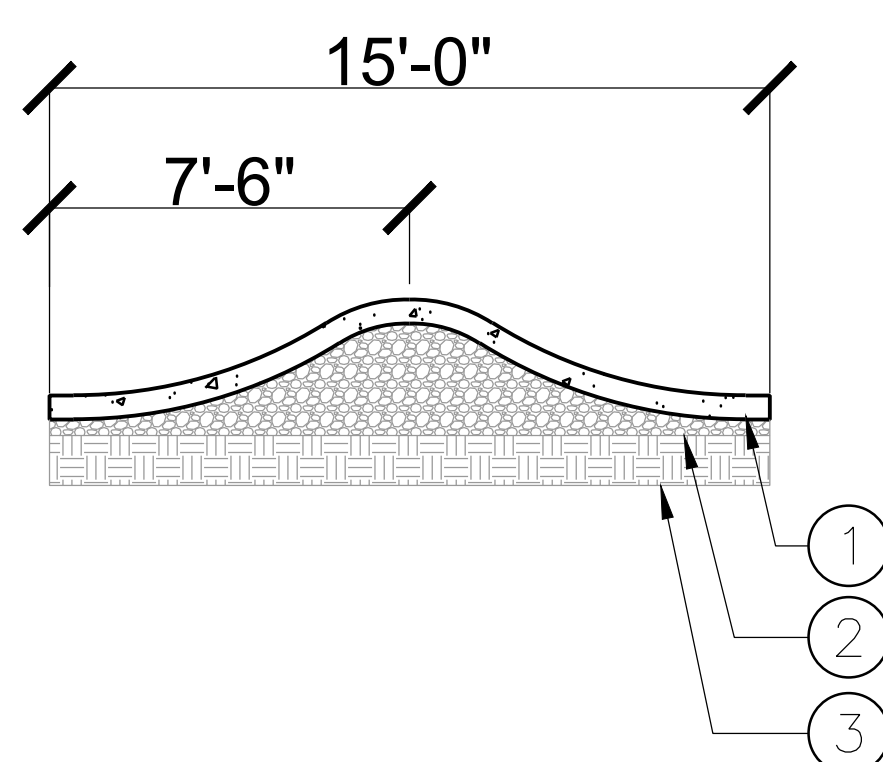
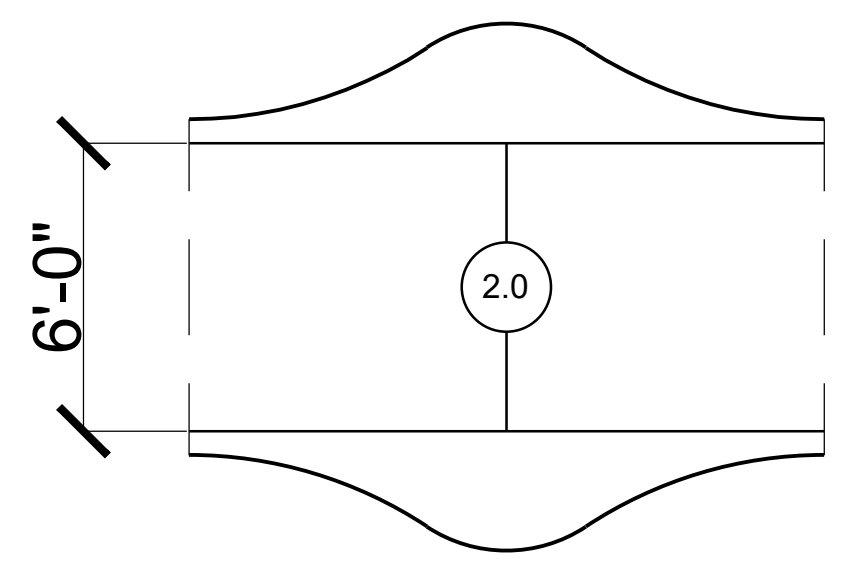

2 ROLLER-SINGLE-2.0'

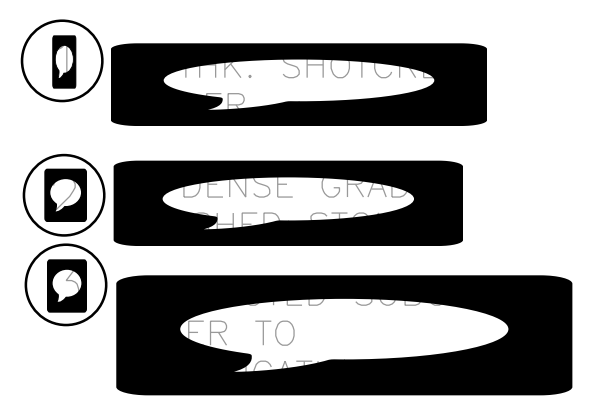
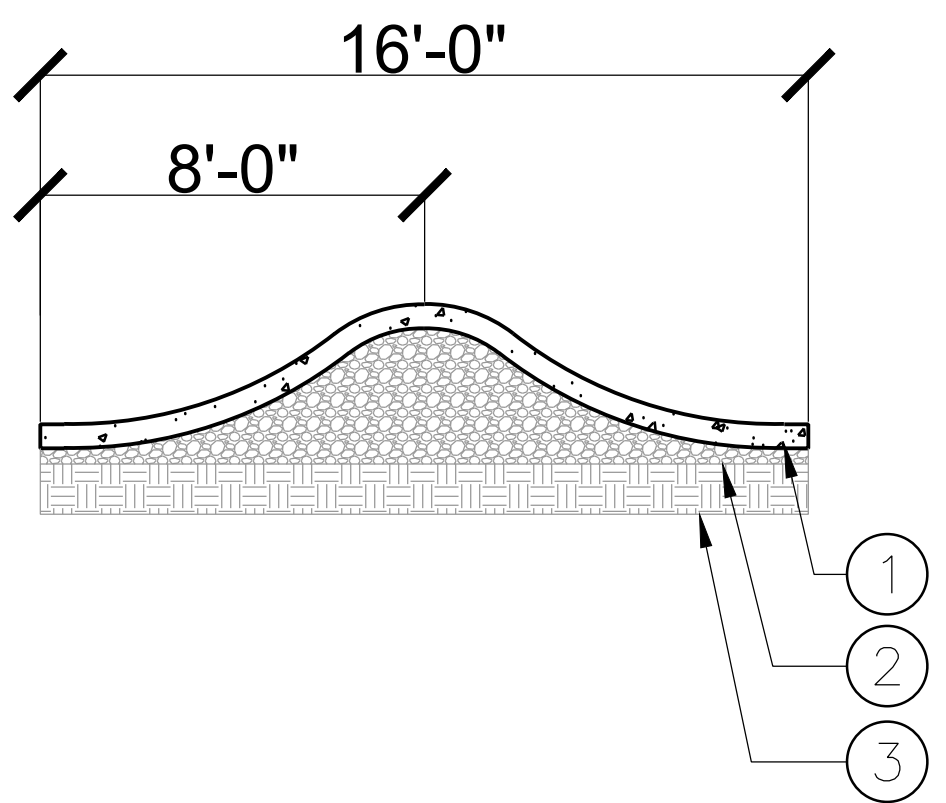
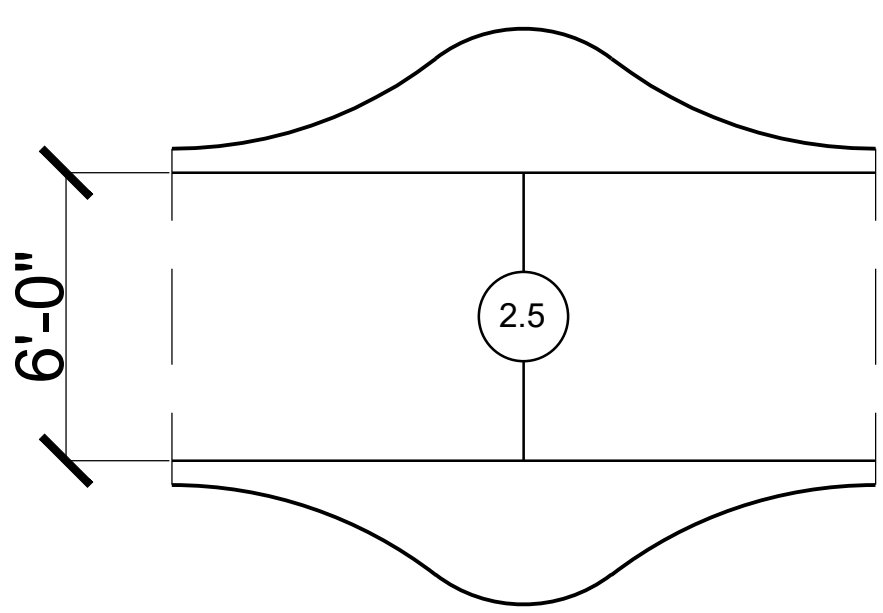

3 ROLLER-SINGLE-2.5'

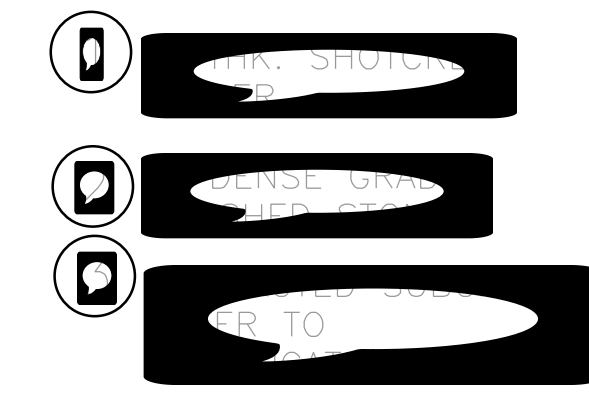
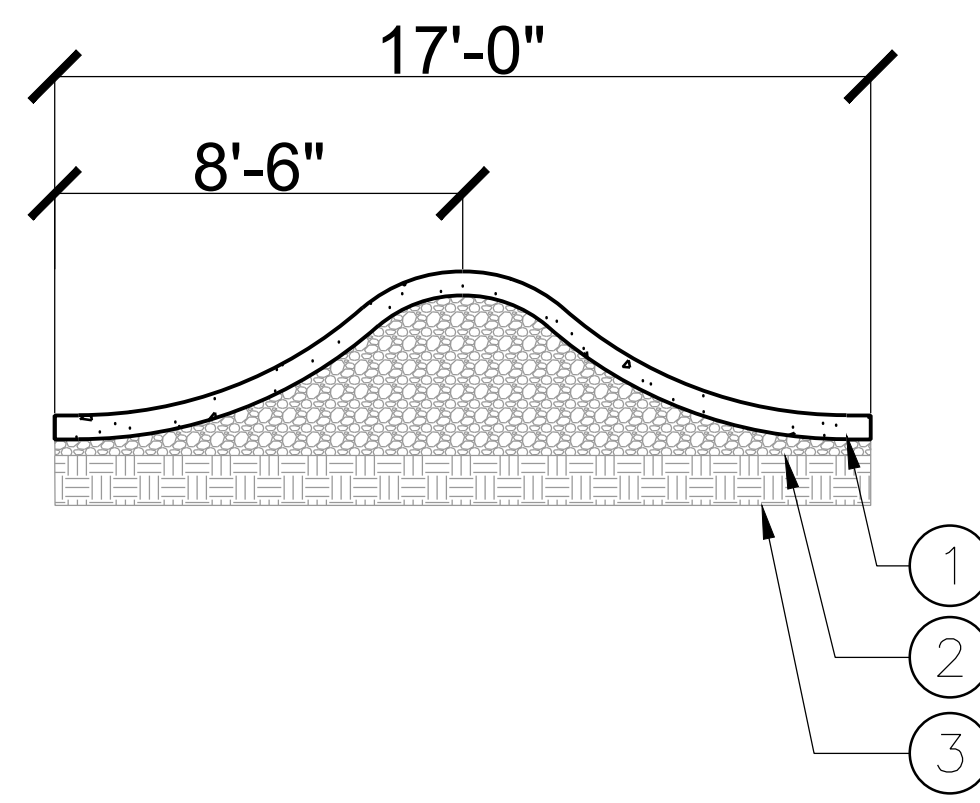
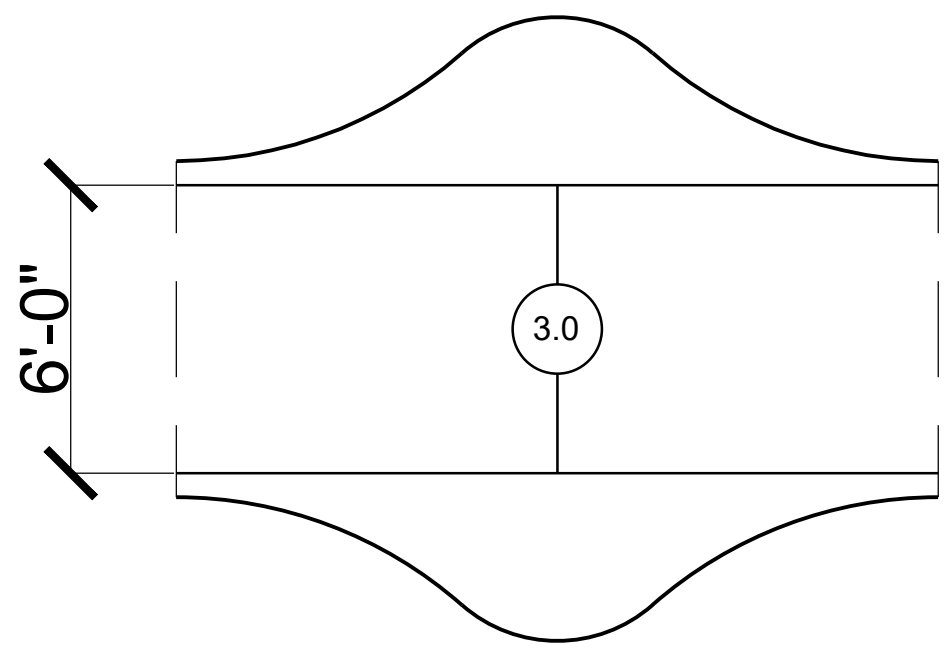

4 ROLLER-SINGLE-3.0'

ISSUED SETS	
Date	Description
01/05/2024	DD SUBMITTAL For Review Only

REVISIONS		
No.	Date	Description

LANDSCAPE ARCHITECT
BENDER WELLS CLARK DESIGN
 830 N. ALAMO ST.
 SAN ANTONIO, TEXAS 78215

Landscape Architecture
Urban Design
Planning

830 North Alamo Street
 San Antonio, Texas 78215
 210-692-9221
 www.bwcdesign.com

© 2023 Bender Wells Clark Design
 All rights reserved. No part of this document may be reproduced or utilized in any form without prior written authorization of Bender Wells Clark Design.

**O. P. Schnabel Bike Park
 Bike Park
 2022 Bond Improvements**

**9700 Rochelle Road
 San Antonio Tx 78240**

This drawing and the design work represented herein are for the site and client and does not apply to any other projects. The reuse of this drawing for any other project is prohibited. Use of this set of drawings requires appropriate authorization from Bender Wells Clark Design.

LANDSCAPE ARCHITECT'S LICENSURE

THESE DOCUMENTS ARE INCOMPLETE AND ARE RELEASED FOR INTERIM REVIEW ONLY, AND NOT INTENDED FOR REGULATORY APPROVAL, BIDDING, PERMIT, OR CONSTRUCTION PURPOSES.

Drawn By : MM/ MJ Checked By : MM

SHEET TITLE & NUMBER:
 FLOW LINE DETAILS

BP-05.01

Date: Jan 05, 2024, 2:24pm User ID: Mitch
 File: C:\Users\Mitch\actionsportsdesign.com\PROJECTS - Documents\TX-San Antonio-OP Schnabel Bike Park-23-050-BP-04-Construction Documents\Sheet Files\BP-FLOW LINES-DETAILS.dwg

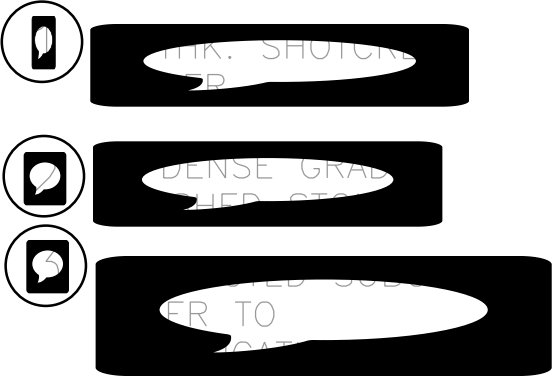
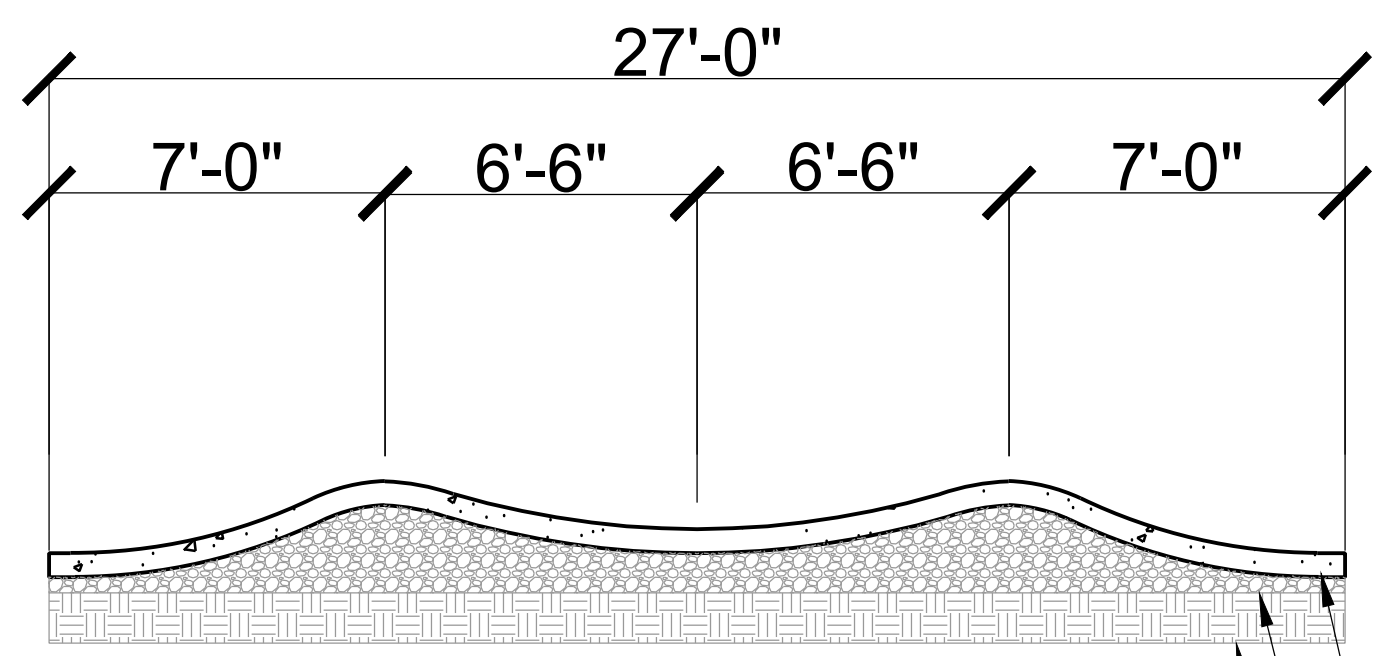
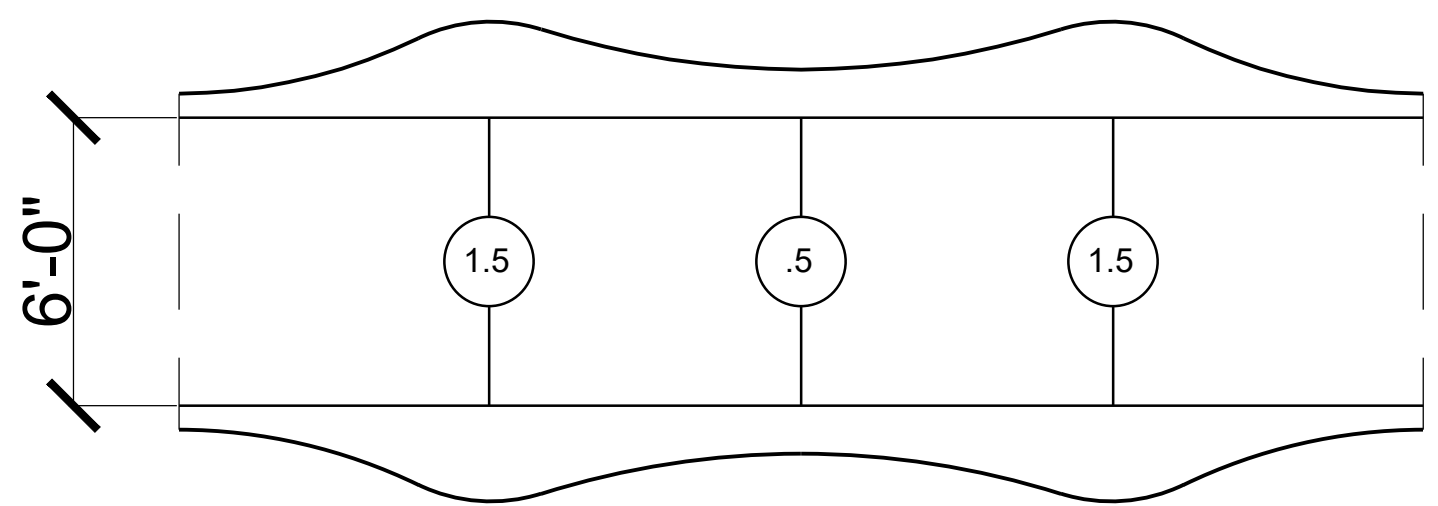

- 1
- 2
- 3

1 ROLLER-DOUBLE-1.5'

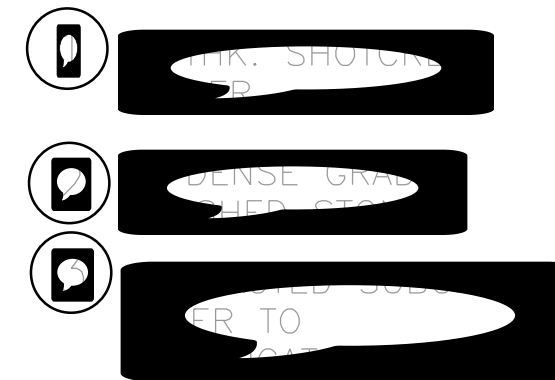
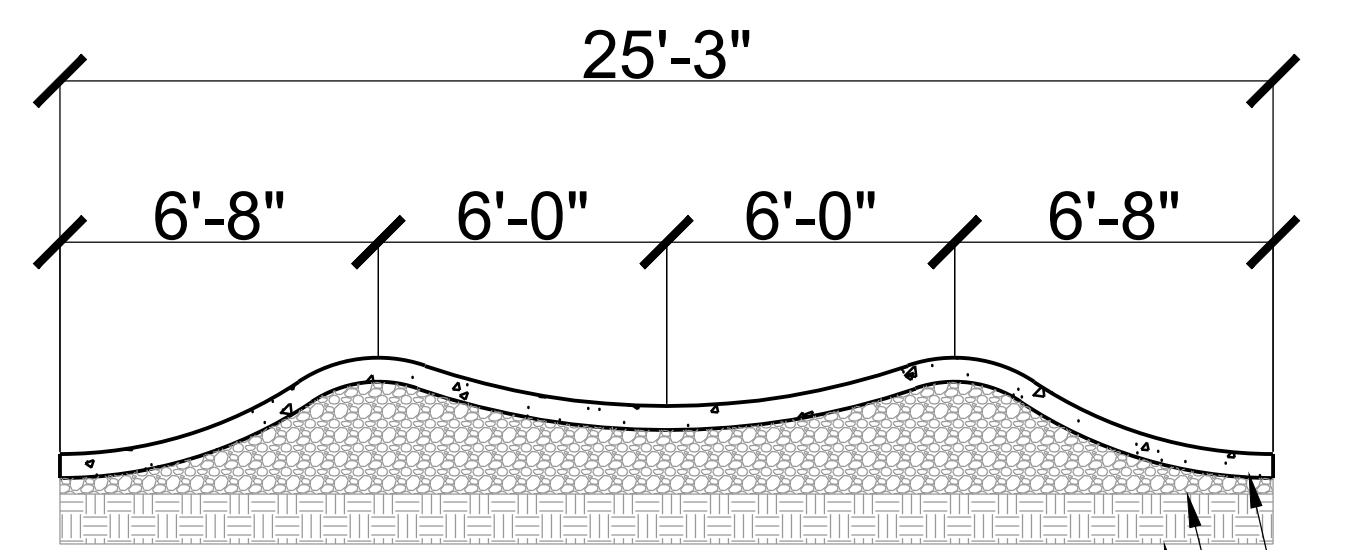
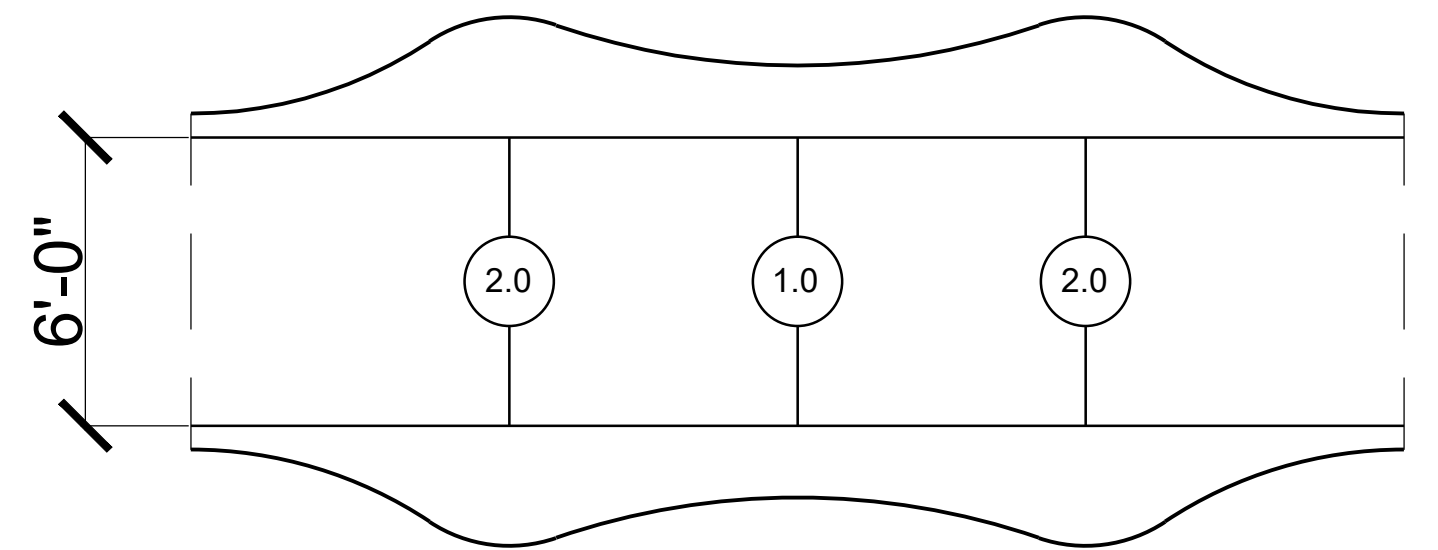

- 1
- 2
- 3

2 ROLLER-DOUBLE-2.0'

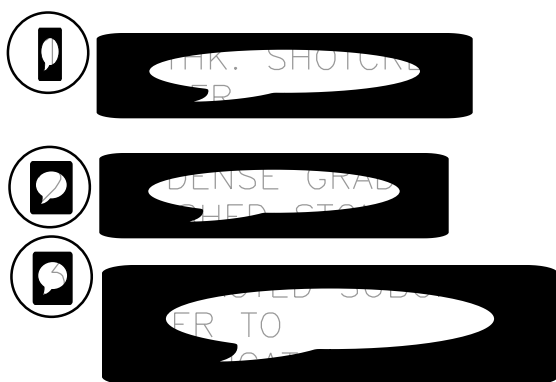
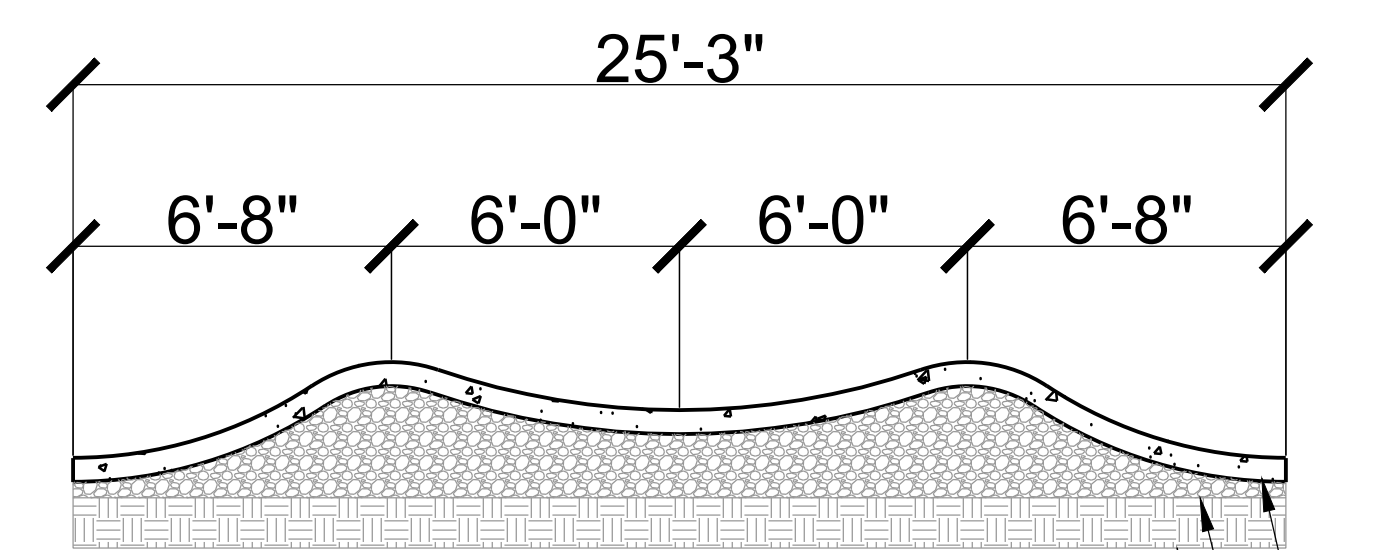
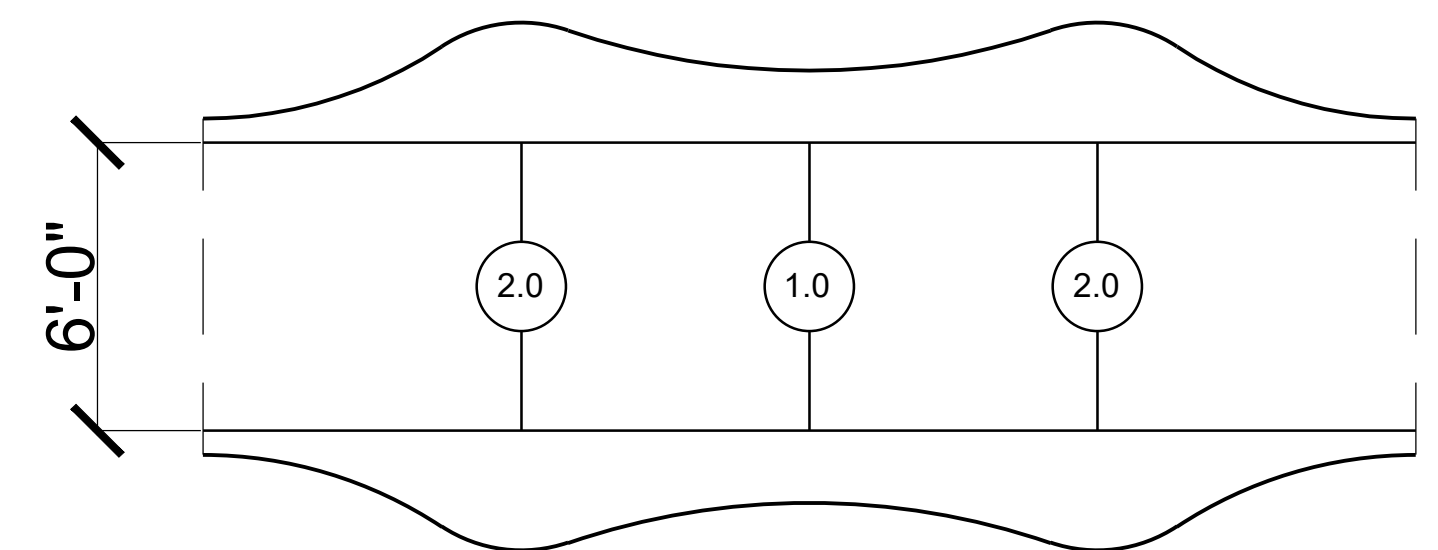

- 1
- 2
- 3

3 ROLLER-DOUBLE-2.5'

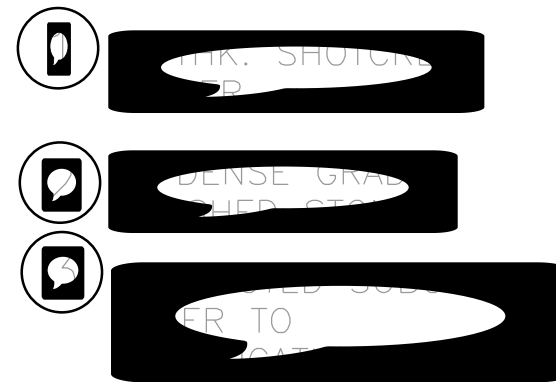
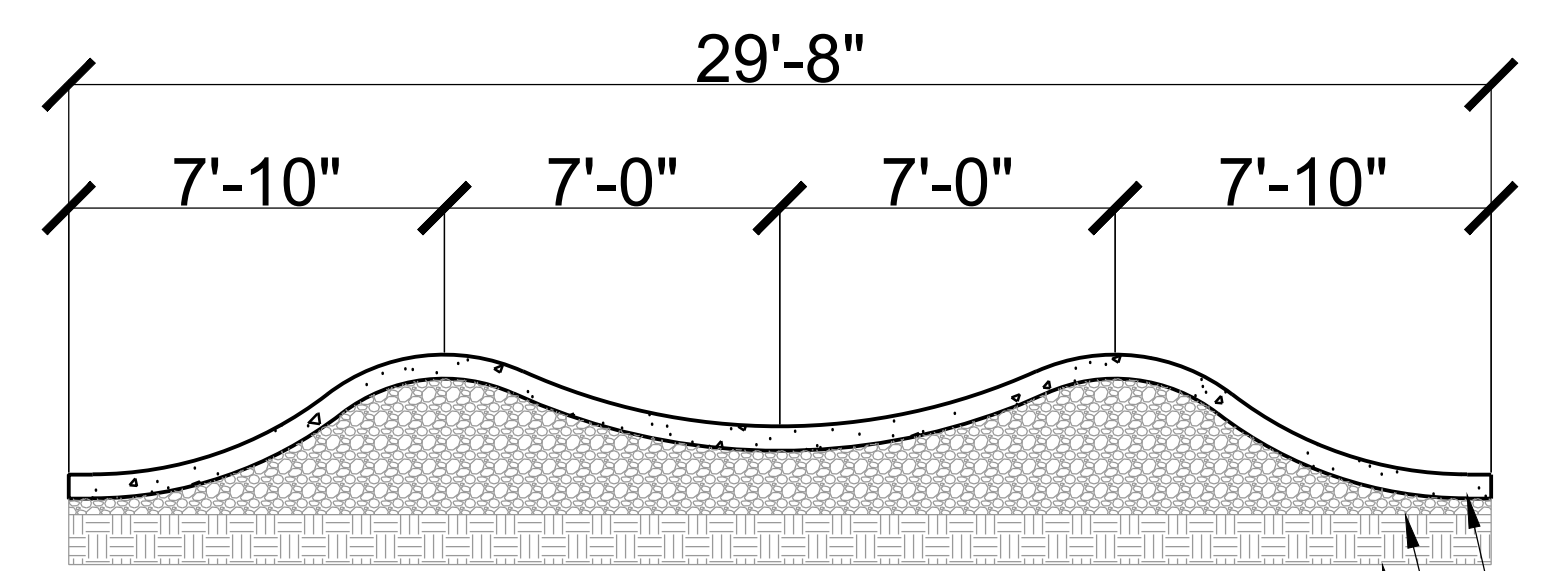
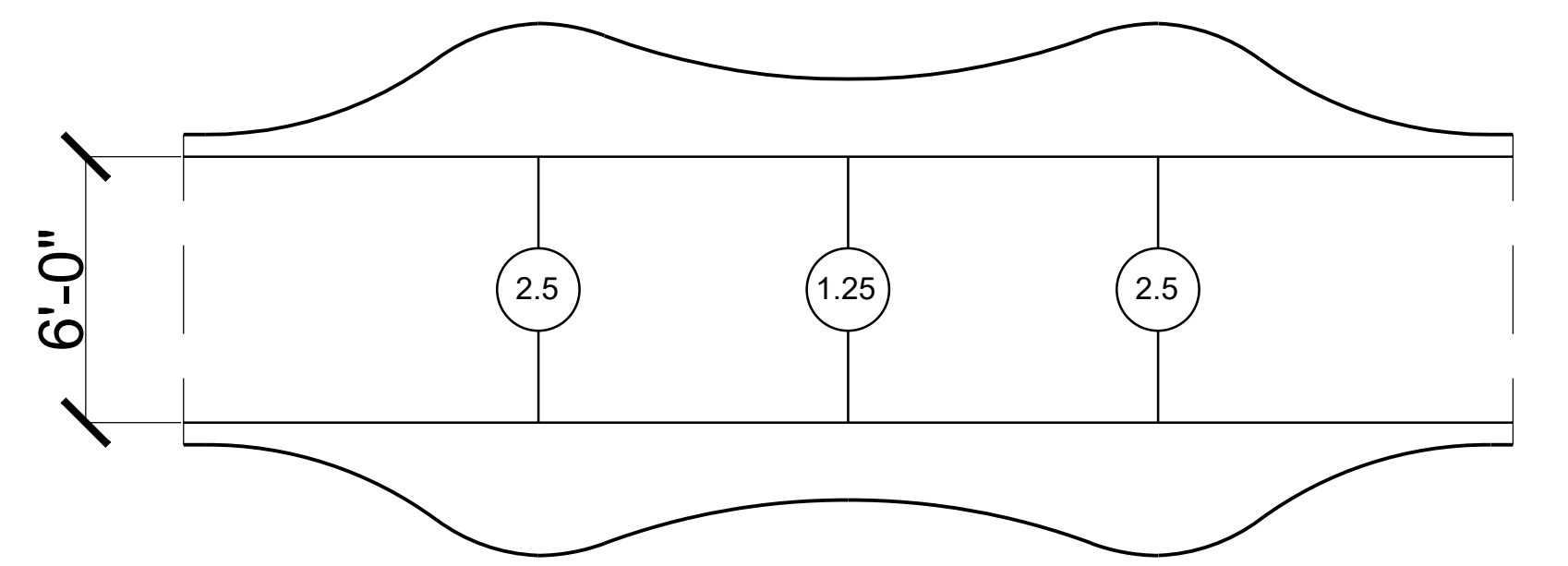

- 1
- 2
- 3

4 ROLLER-DOUBLE-3.0'

ISSUED SETS	
Date	Description
01/05/2024	DD SUBMITTAL For Review Only

REVISIONS		
No.	Date	Description

LANDSCAPE ARCHITECT
BENDER WELLS CLARK DESIGN
 830 N. ALAMO ST.
 SAN ANTONIO, TEXAS 78215

Landscape Architecture
Urban Design
Planning

830 North Alamo Street
 San Antonio, Texas 78215
 210-692-9221
 www.bwcdesign.com

© 2023 Bender Wells Clark Design
 All rights reserved. No part of this document may be reproduced or utilized in any form without prior written authorization of Bender Wells Clark Design.

**O. P. Schnabel Bike Park
 Bike Park
 2022 Bond Improvements**

**9700 Rochelle Road
 San Antonio Tx 78240**

This drawing and the design was prepared specifically for this site and client and does not apply to any other projects. The reuse of this design for any other project is prohibited. Use of this set of drawings requires appropriate authorization from Bender Wells Clark Design.

LANDSCAPE ARCHITECT'S LICENSURE

THESE DOCUMENTS ARE INCOMPLETE AND ARE RELEASED FOR INTERIM REVIEW ONLY, AND NOT INTENDED FOR REGULATORY APPROVAL, BIDDING, PERMIT, OR CONSTRUCTION PURPOSES.

Drawn By : MM/ MJ Checked By : MM

SHEET TITLE & NUMBER:
 FLOW LINE DETAILS
BP-05.02

Date: Jan 05, 2024, 2:28pm User ID: Mitch
 File: C:\Users\Mitch\actionsportsdesign.com\PROJECTS - Documents\TX-San Antonio-OP Schnabel Bike Park-23-050-BP\04-Construction Documents\Sheet Files\BP-FLOW LINES-DETAILS.dwg

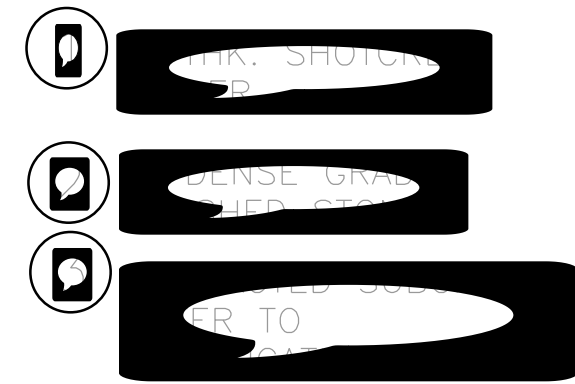
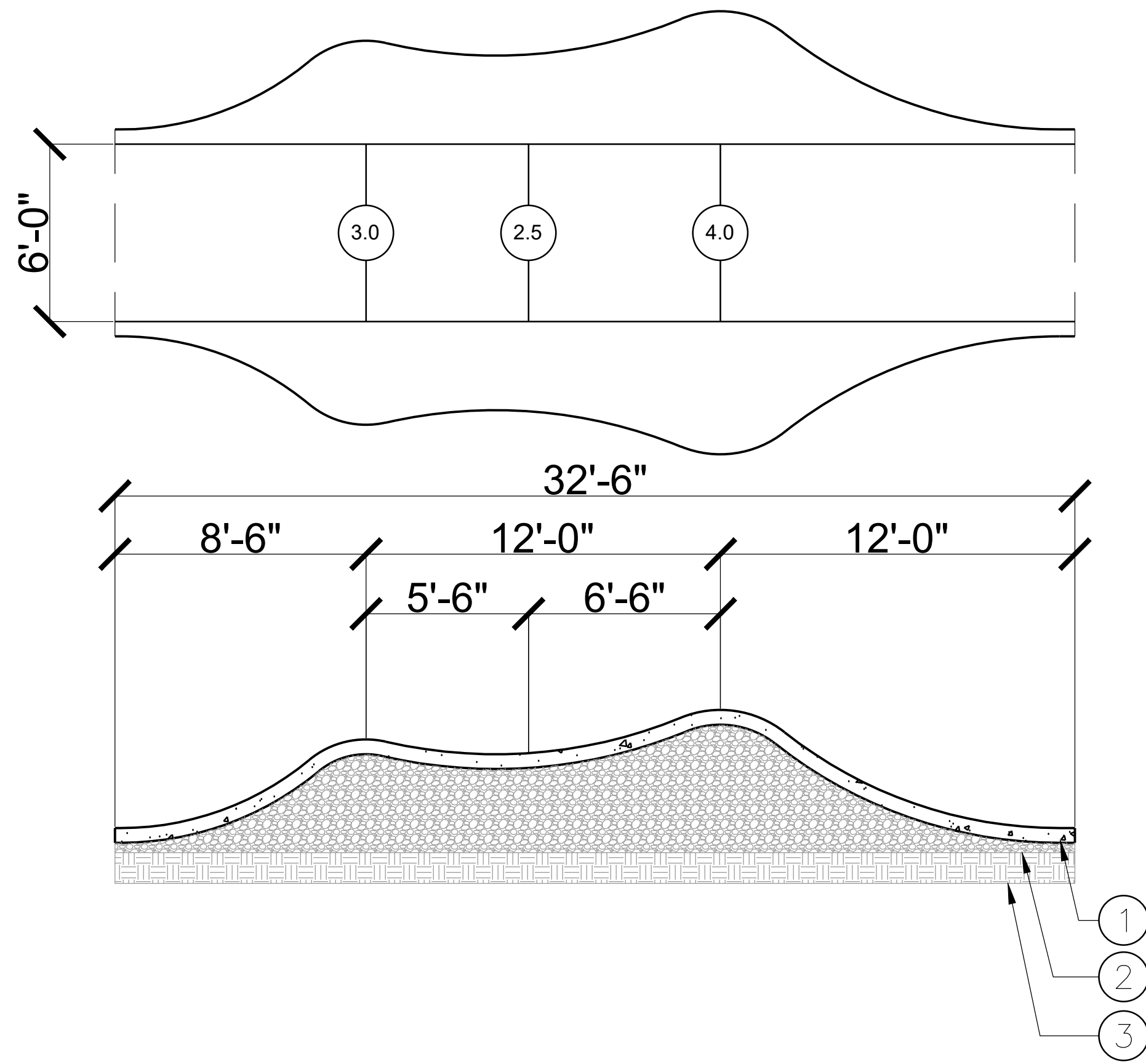

1 JUMP-DOUBLE-3.0'-4.0'

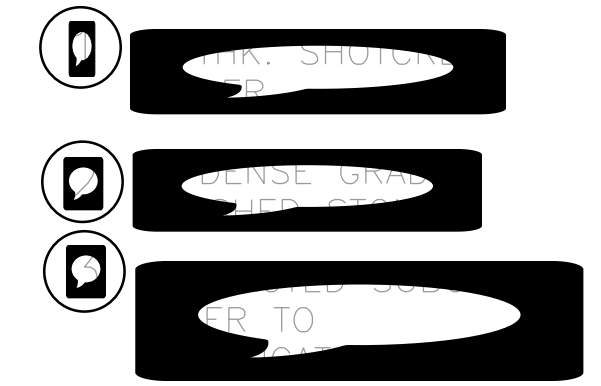
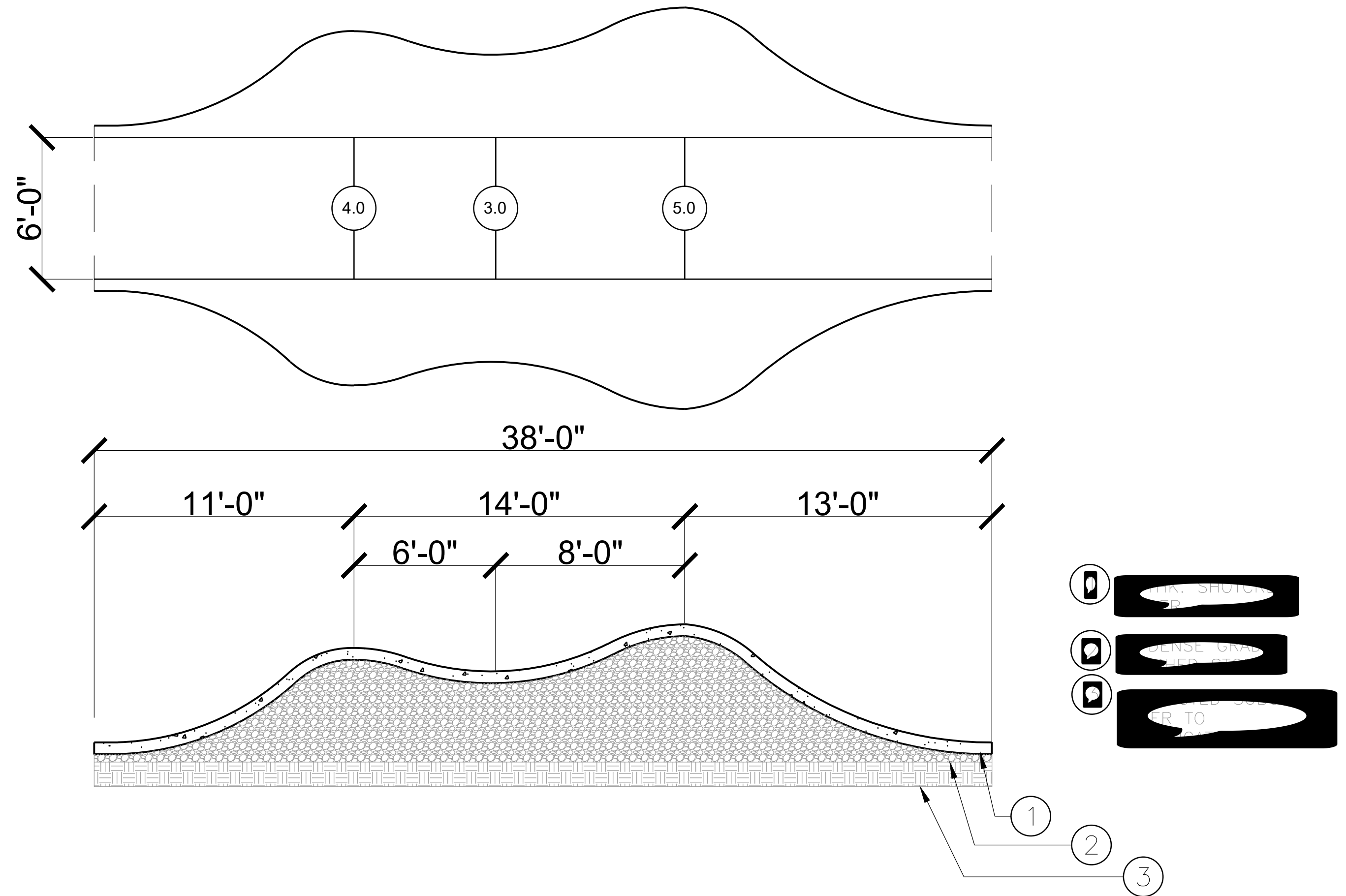

2 JUMP-DOUBLE-4.0'-5.0'

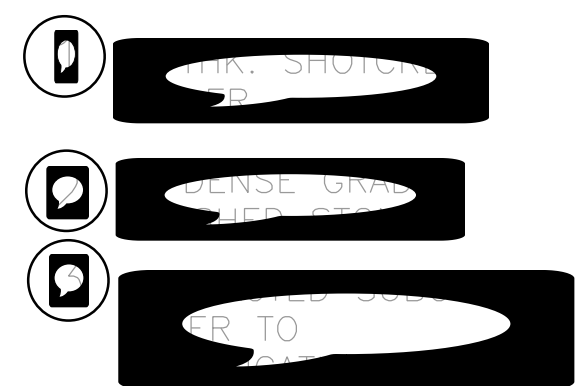
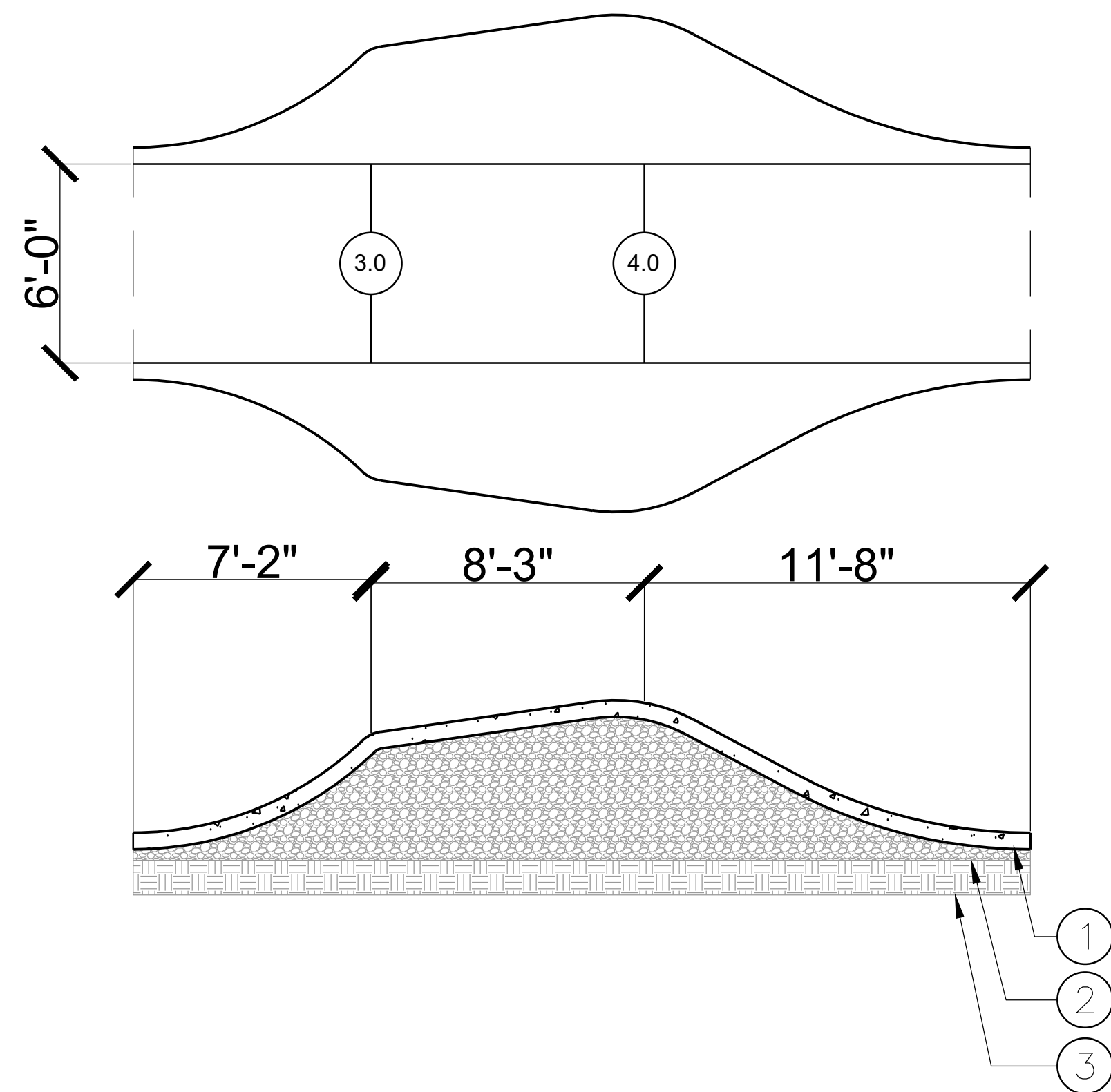

3 JUMP-TABLE-3.0'-4.0'

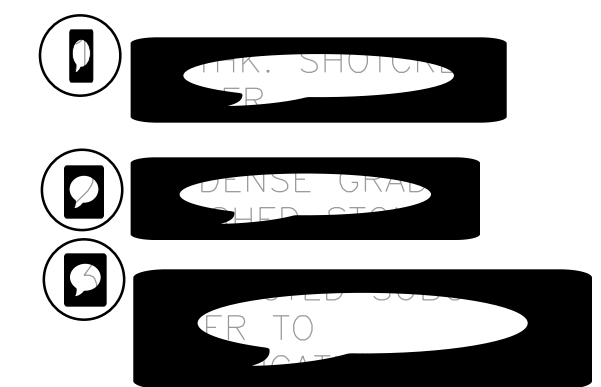
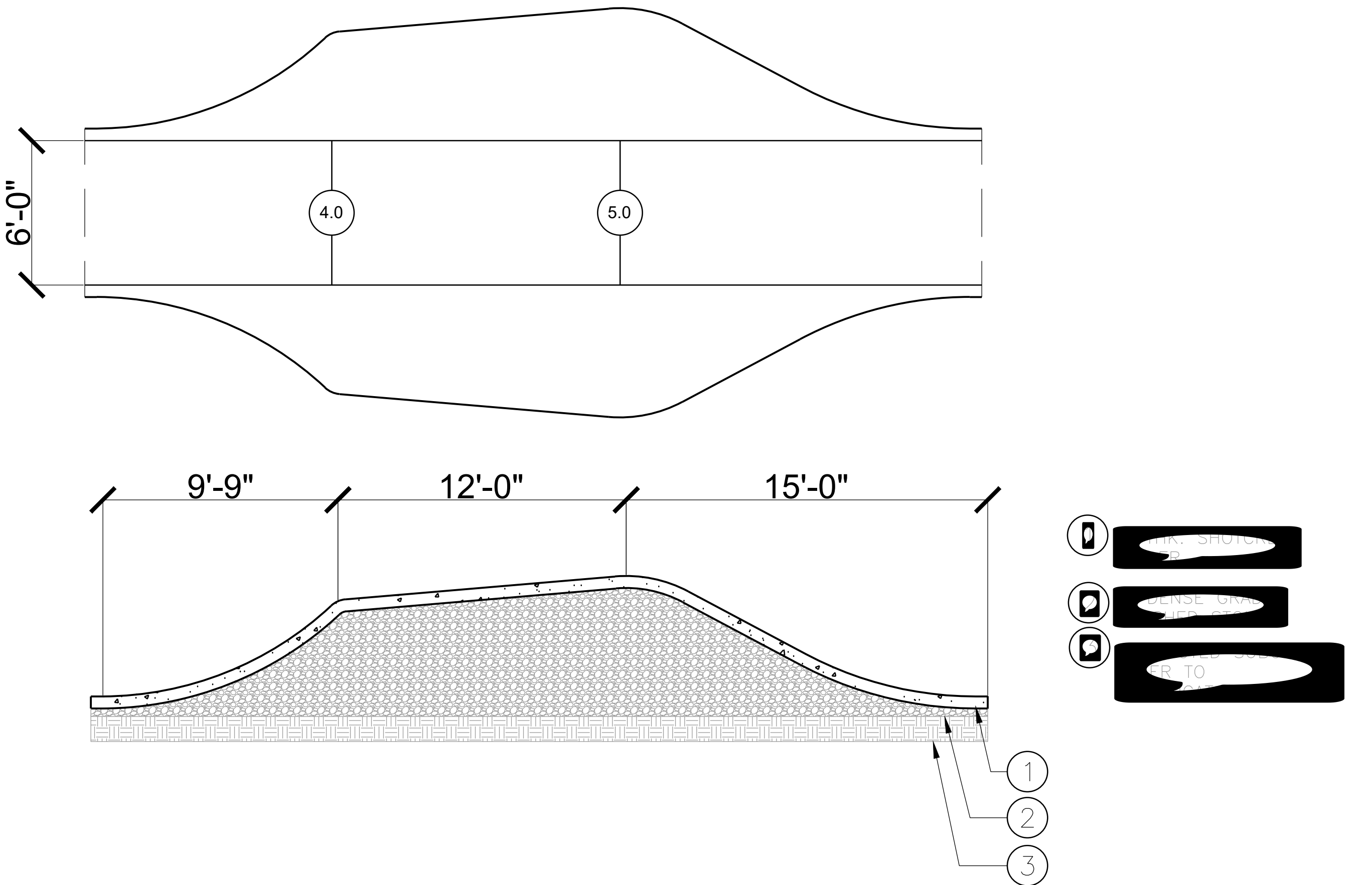

4 JUMP-TABLE-4.0'-5.0'

ISSUED SETS	
Date	Description
01/05/2024	DD SUBMITTAL For Review Only

REVISIONS		
No.	Date	Description

LANDSCAPE ARCHITECT
BENDER WELLS CLARK DESIGN
 830 N. ALAMO ST.
 SAN ANTONIO, TEXAS 78215



© 2023 Bender Wells Clark Design
 All rights reserved. No part of this document may be reproduced or utilized in any form without prior written authorization of Bender Wells Clark Design.

**O. P. Schnabel Bike Park
 Bike Park
 2022 Bond Improvements**

**9700 Rochelle Road
 San Antonio Tx 78240**

This drawing and the design was prepared specifically for this site and client and does not apply to any other projects. The reuse of this drawing for any other project is prohibited. Use of this set of drawings requires appropriate authorization from Bender Wells Clark Design.

LANDSCAPE ARCHITECT'S LICENSURE

THESE DOCUMENTS ARE INCOMPLETE AND ARE RELEASED FOR INTERIM REVIEW ONLY, AND NOT INTENDED FOR REGULATORY APPROVAL, BIDDING, PERMIT, OR CONSTRUCTION PURPOSES.

Drawn By : MM/ MJ Checked By : MM

SHEET TITLE & NUMBER:
 FLOW LINE
 DETAILS

BP-05.03

1 BERM-3.0'

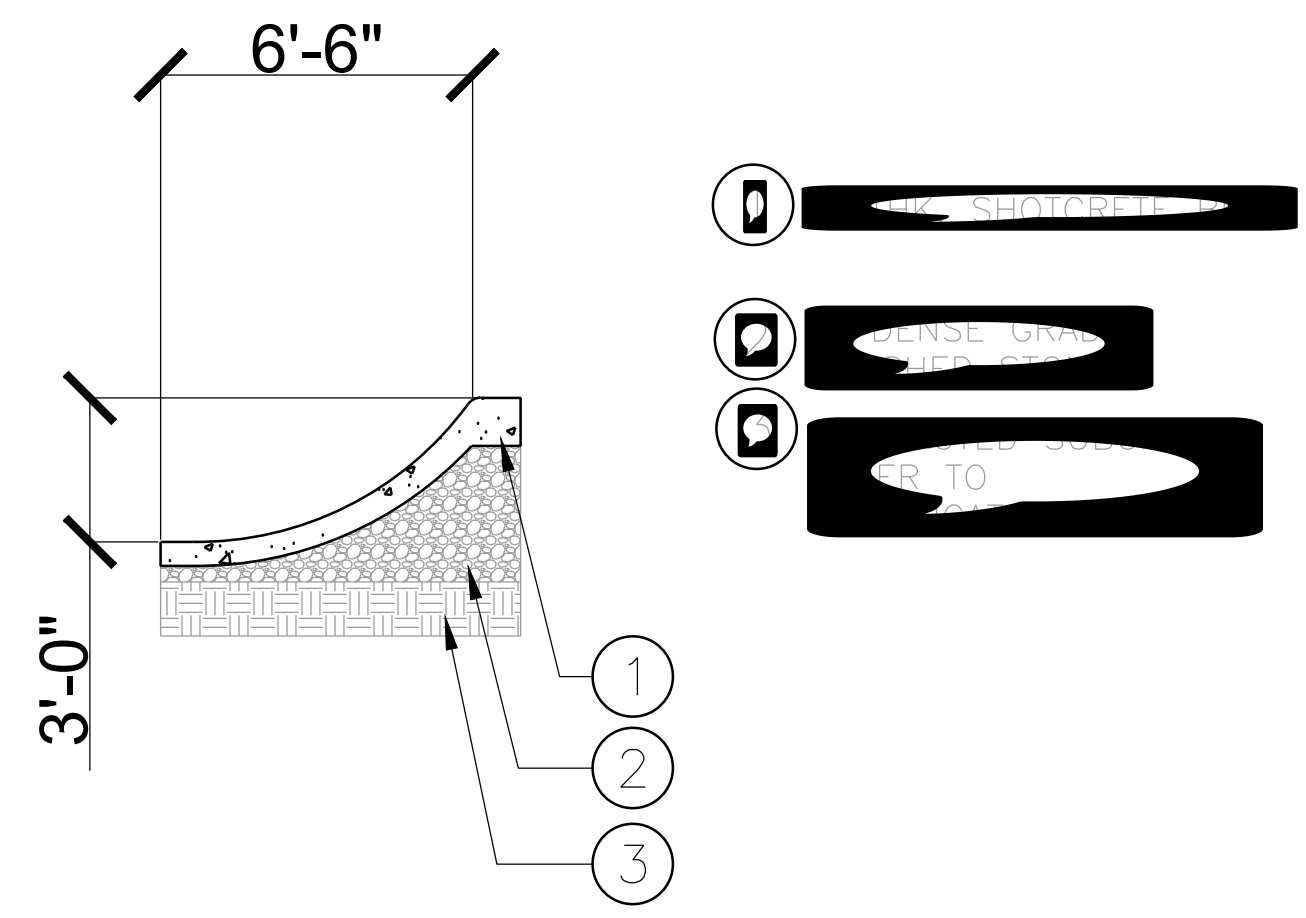

2 BERM-4.0'

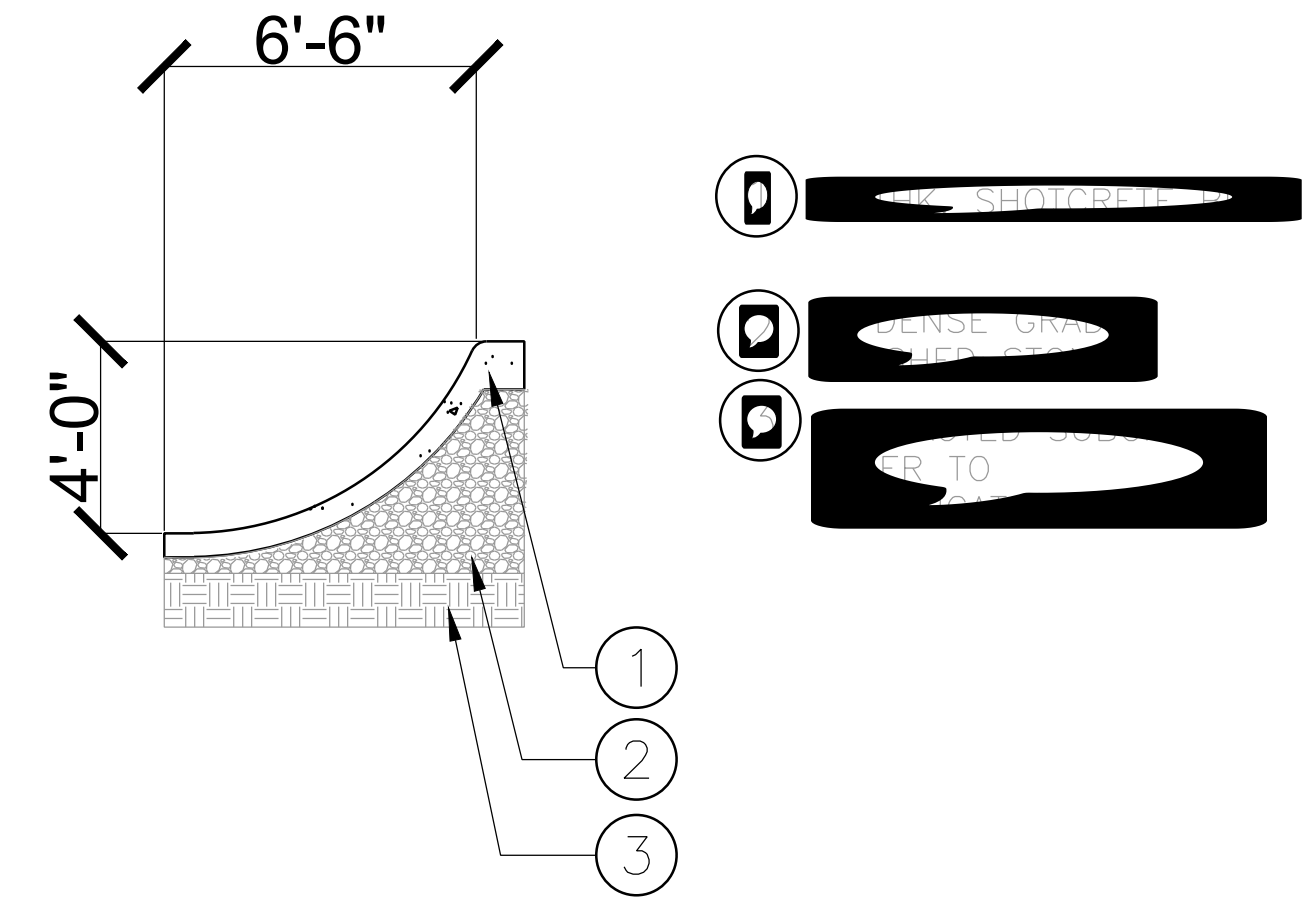

3 BERM-5.0'

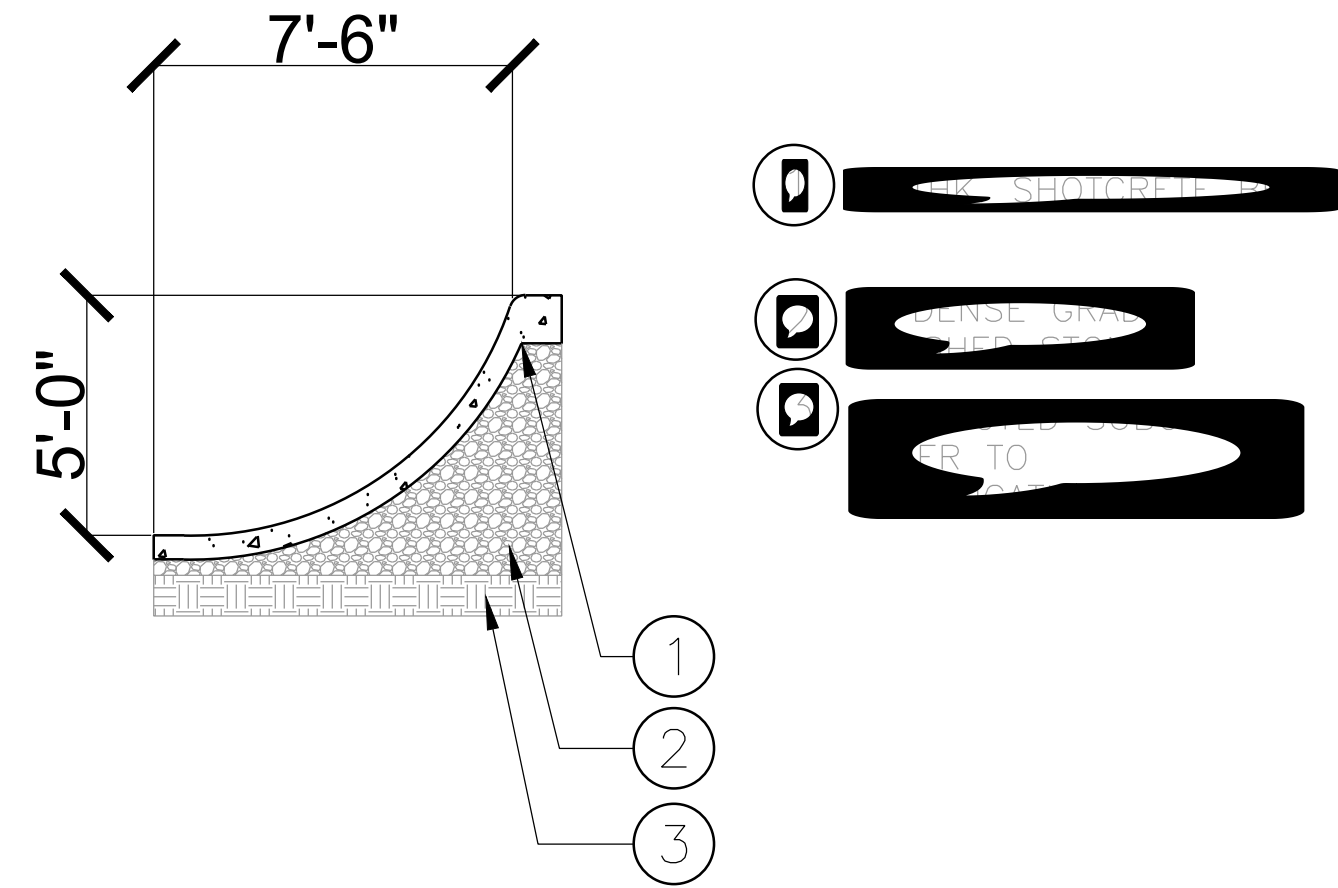

4 BERM-6.0'

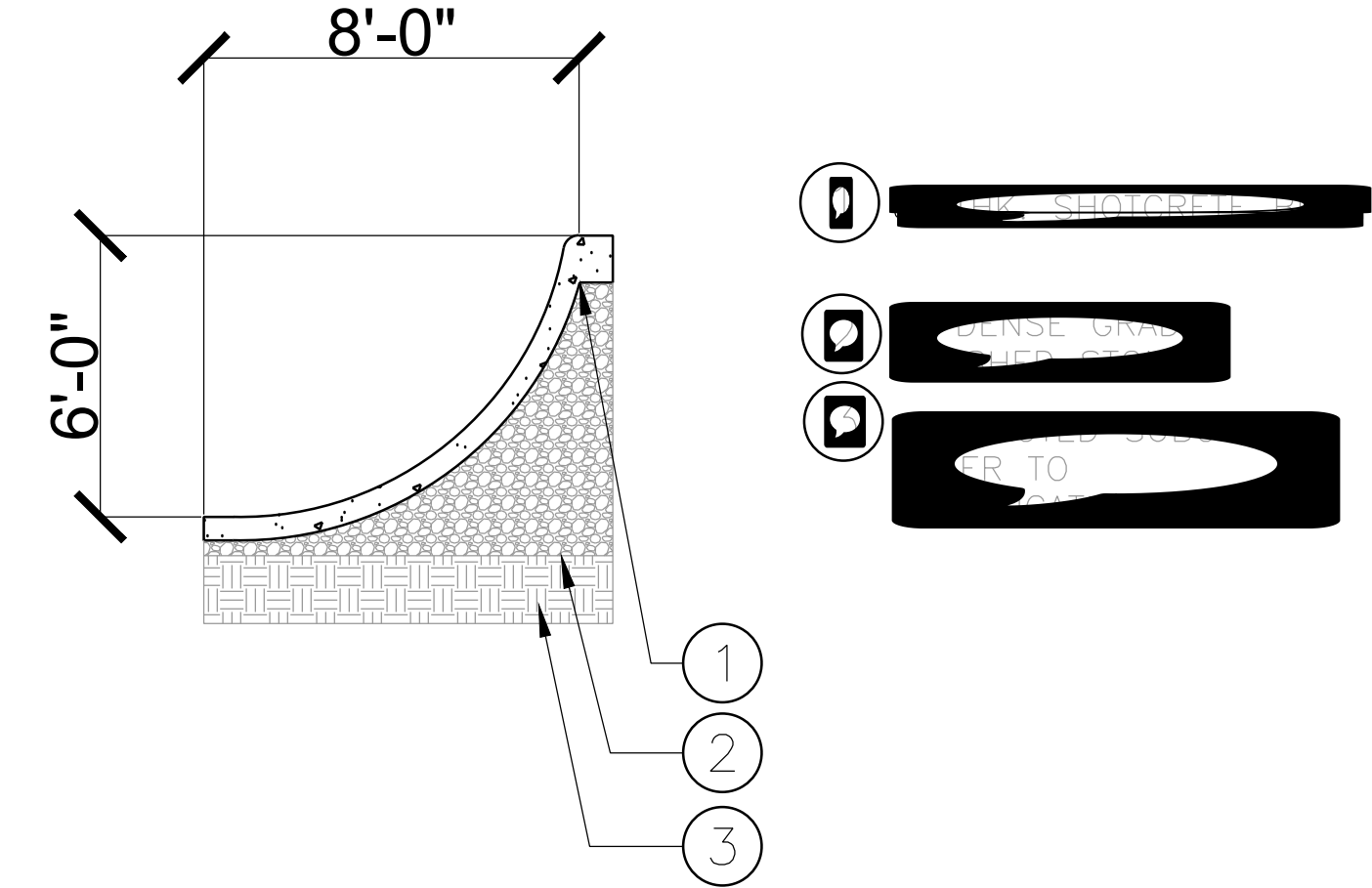

ISSUED SETS	
Date	Description
01/05/2024	DD SUBMITTAL For Review Only

REVISIONS		
No.	Date	Description

LANDSCAPE ARCHITECT
BENDER WELLS CLARK DESIGN
 830 N. ALAMO ST.
 SAN ANTONIO, TEXAS 78215

Landscape Architecture
Urban Design
Planning

830 North Alamo Street
 San Antonio, Texas 78215
 210-692-9221
 www.bwcdesign.com

© 2023 Bender Wells Clark Design
 All rights reserved. No part of this document may be reproduced or utilized in any form without prior written authorization of Bender Wells Clark Design.

**O. P. Schnabel Bike Park
 Bike Park
 2022 Bond Improvements**

**9700 Rochelle Road
 San Antonio Tx 78240**

This drawing and the design work represented herein are the property of Bender Wells Clark Design. The reproduction or use of this drawing for any other project, without the prior written consent of Bender Wells Clark Design, is prohibited. Use of this set of drawings requires appropriate authorization from Bender Wells Clark Design.

LANDSCAPE ARCHITECT'S LICENSURE

THESE DOCUMENTS ARE INCOMPLETE AND ARE RELEASED FOR INTERIM REVIEW ONLY, AND NOT INTENDED FOR REGULATORY APPROVAL, BIDDING, PERMIT, OR CONSTRUCTION PURPOSES.

Drawn By : MM/ MJ Checked By : MM

SHEET TITLE & NUMBER:
 FLOW LINE
 DETAILS
BP-05.04

Date: Jan 05, 2024, 2:30pm User ID: Mitch
 File: C:\Users\Mitch\actionsportsdesign.com\PROJECTS - Documents\TX-San Antonio-OP Schnabel Bike Park-23-050-BP\04-Construction Documents\Sheet Files\BP-FLOW LINES-DETAILS.dwg

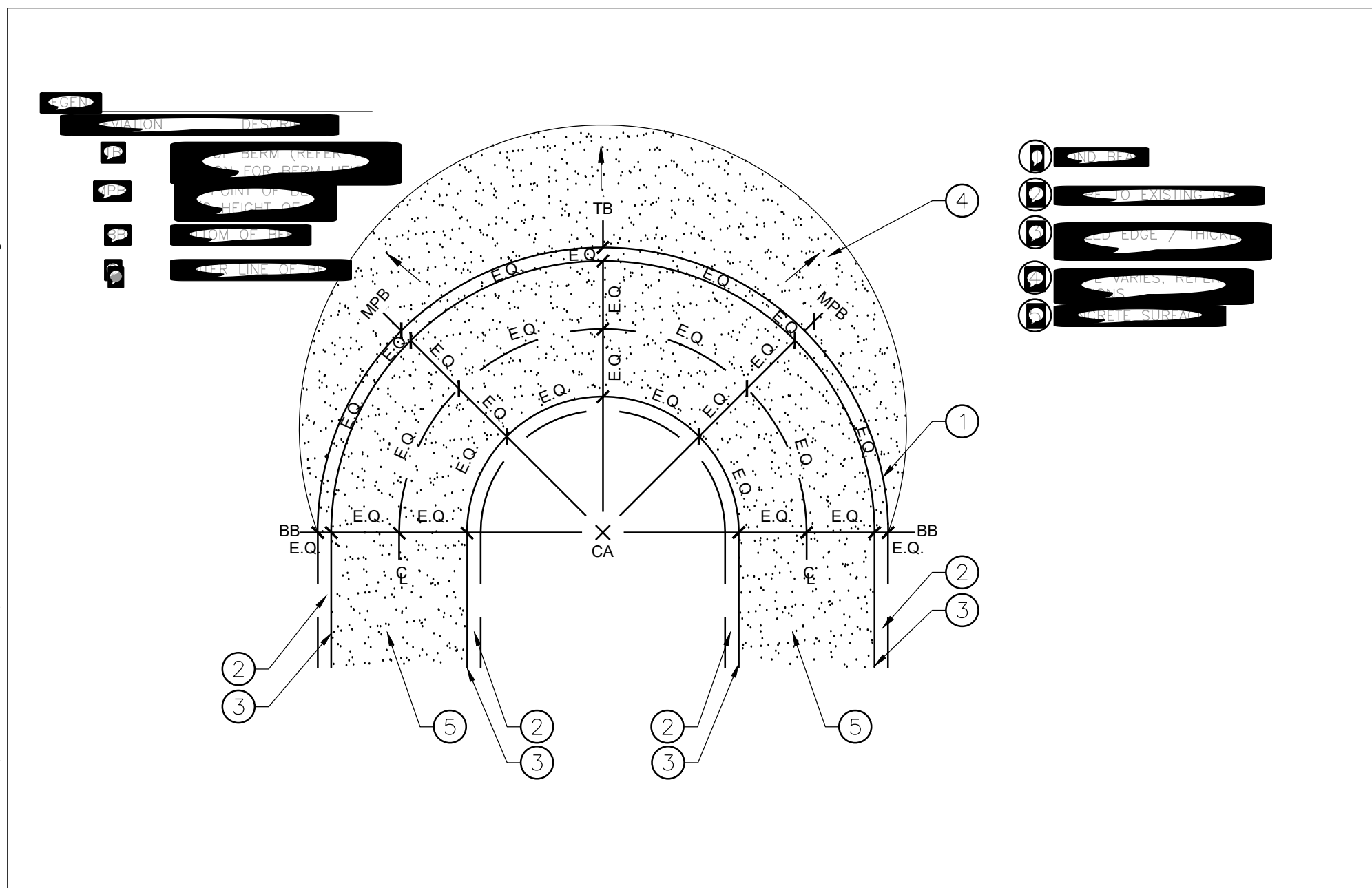

1 SHOTCRETE BERM-TYPICAL

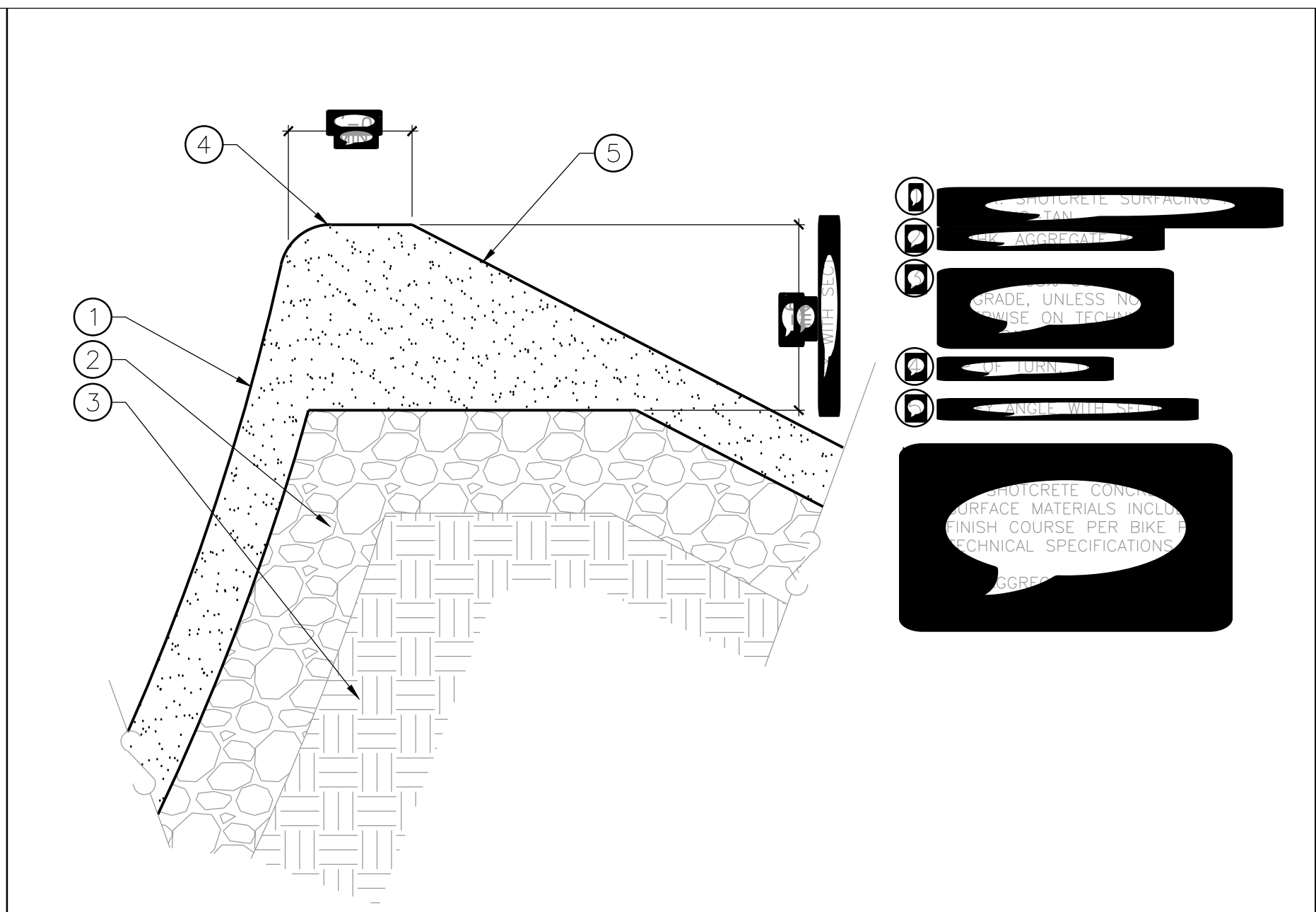

2 SHOTCRETE BERM-BOND BEAM

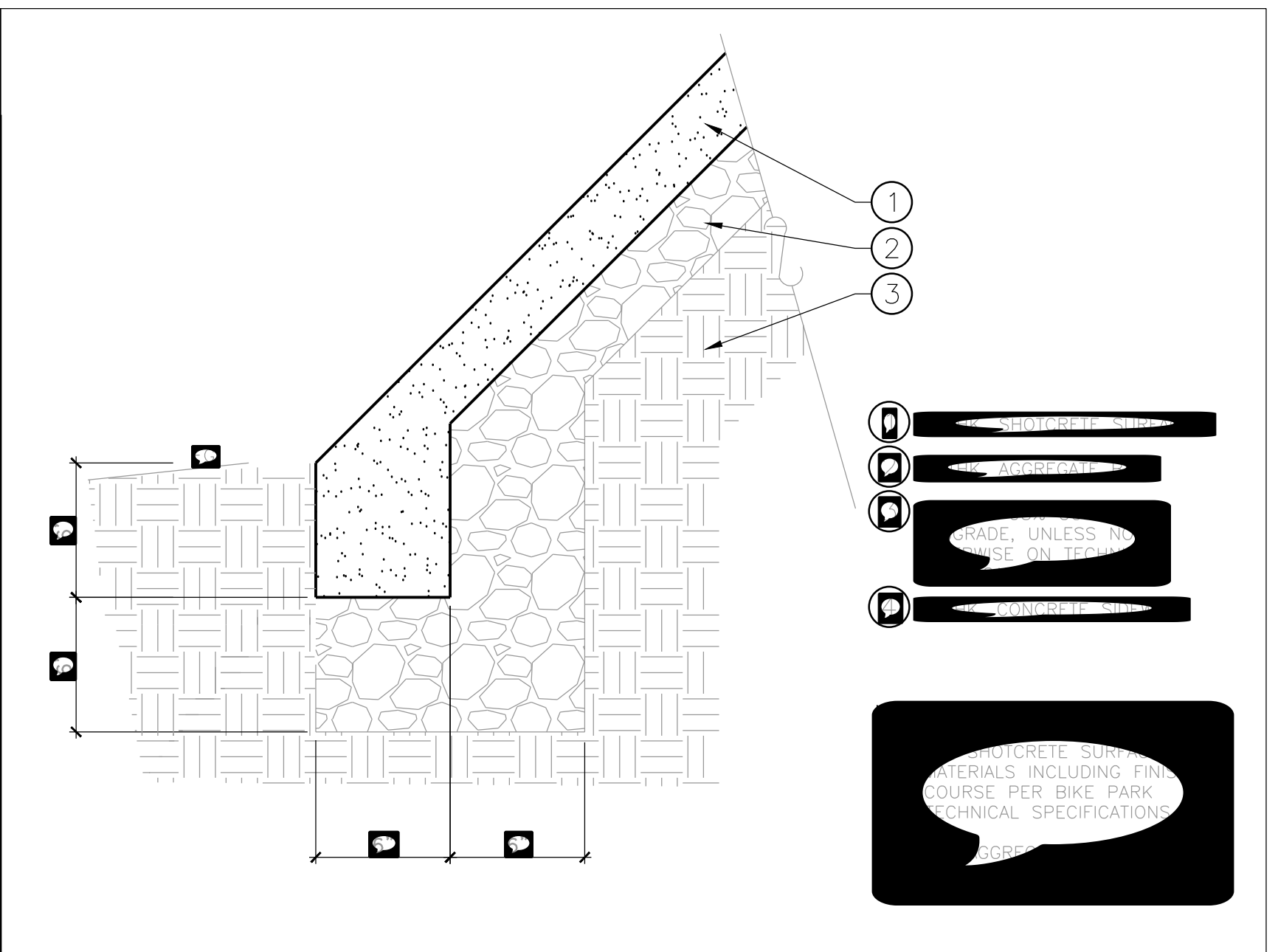

3 BACK OF BERM-THICKENED EDGE

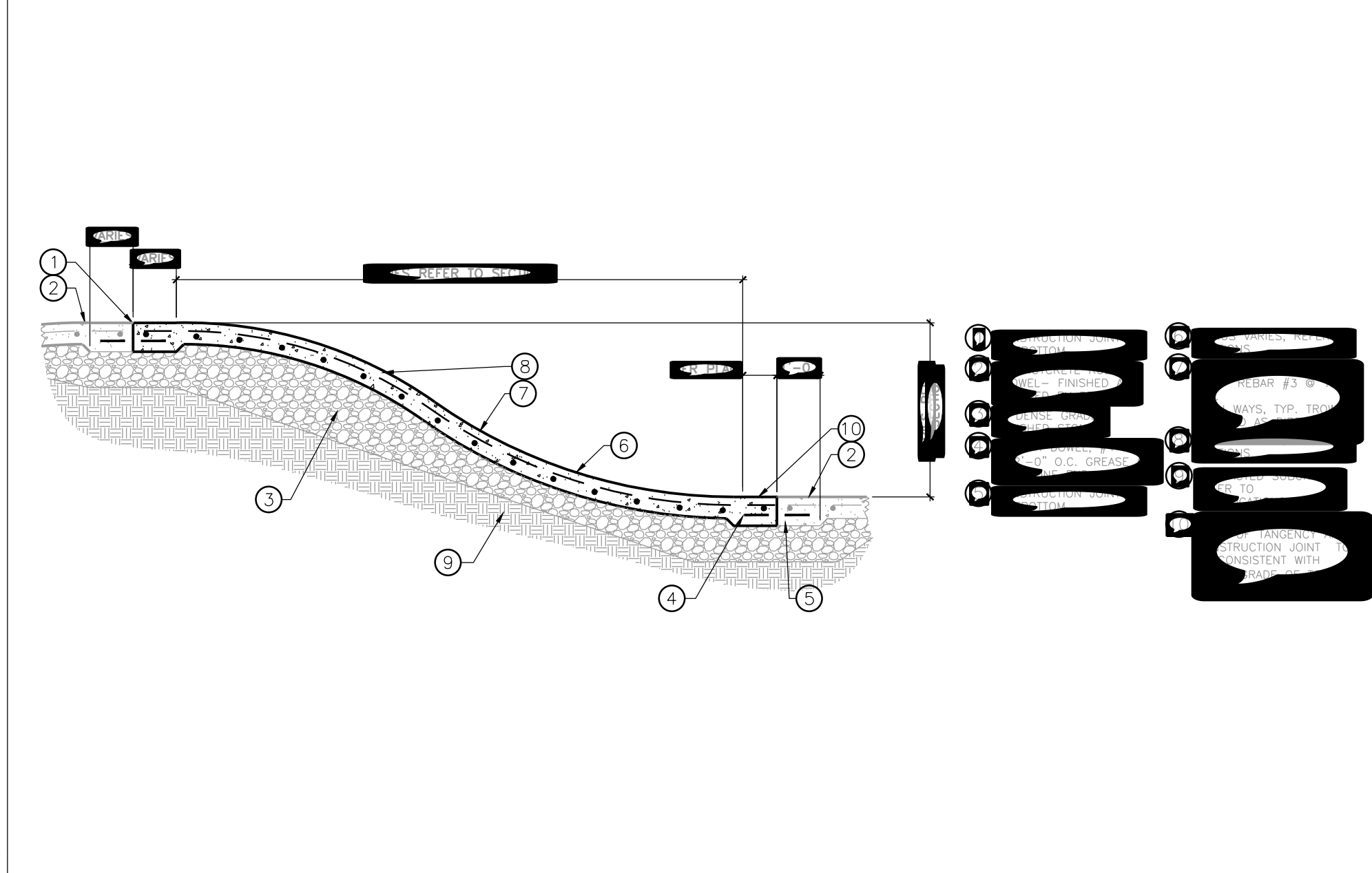

4 SHOTCRETE ROLLER-TYPICAL

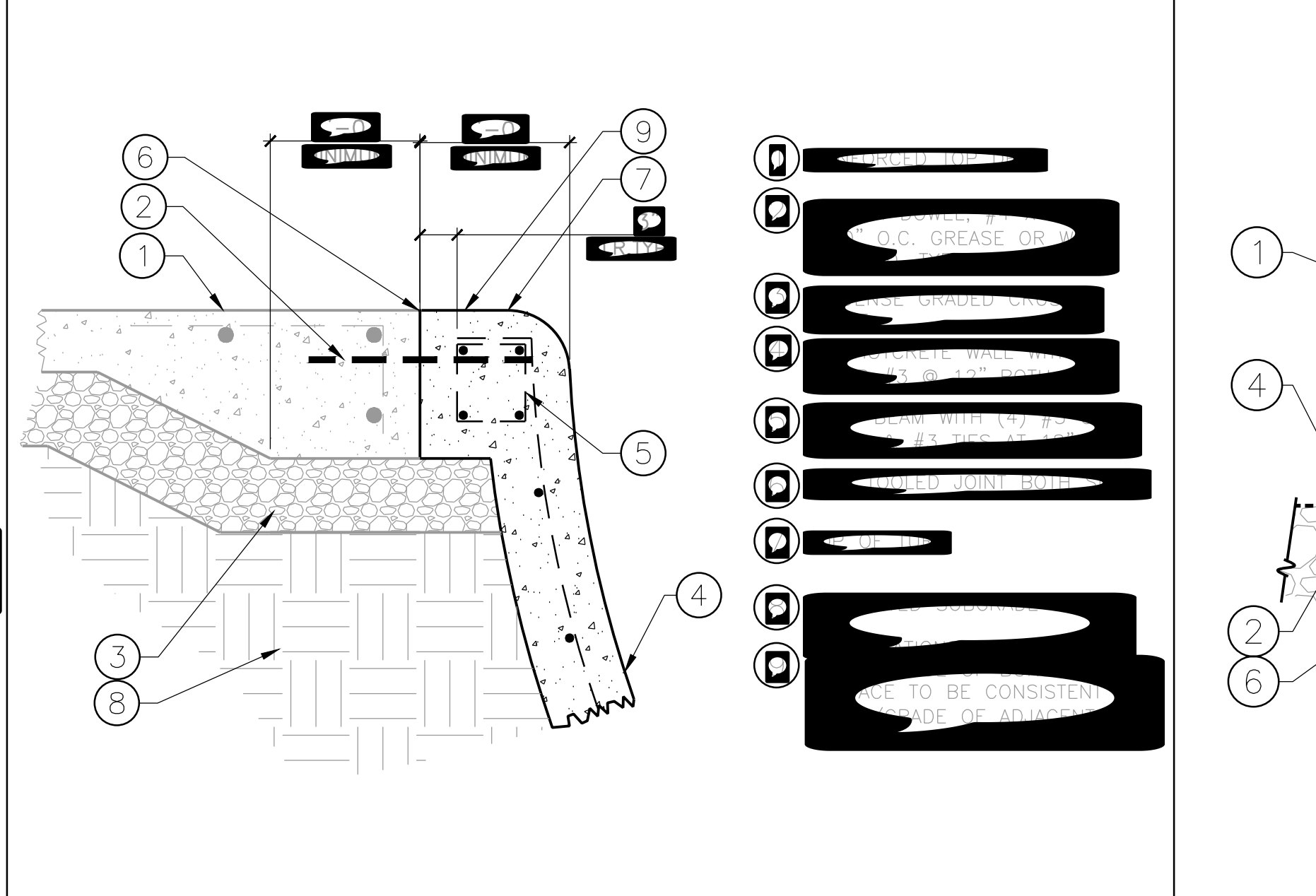

5 SHOTCRETE BOND BEAM-TYPICAL

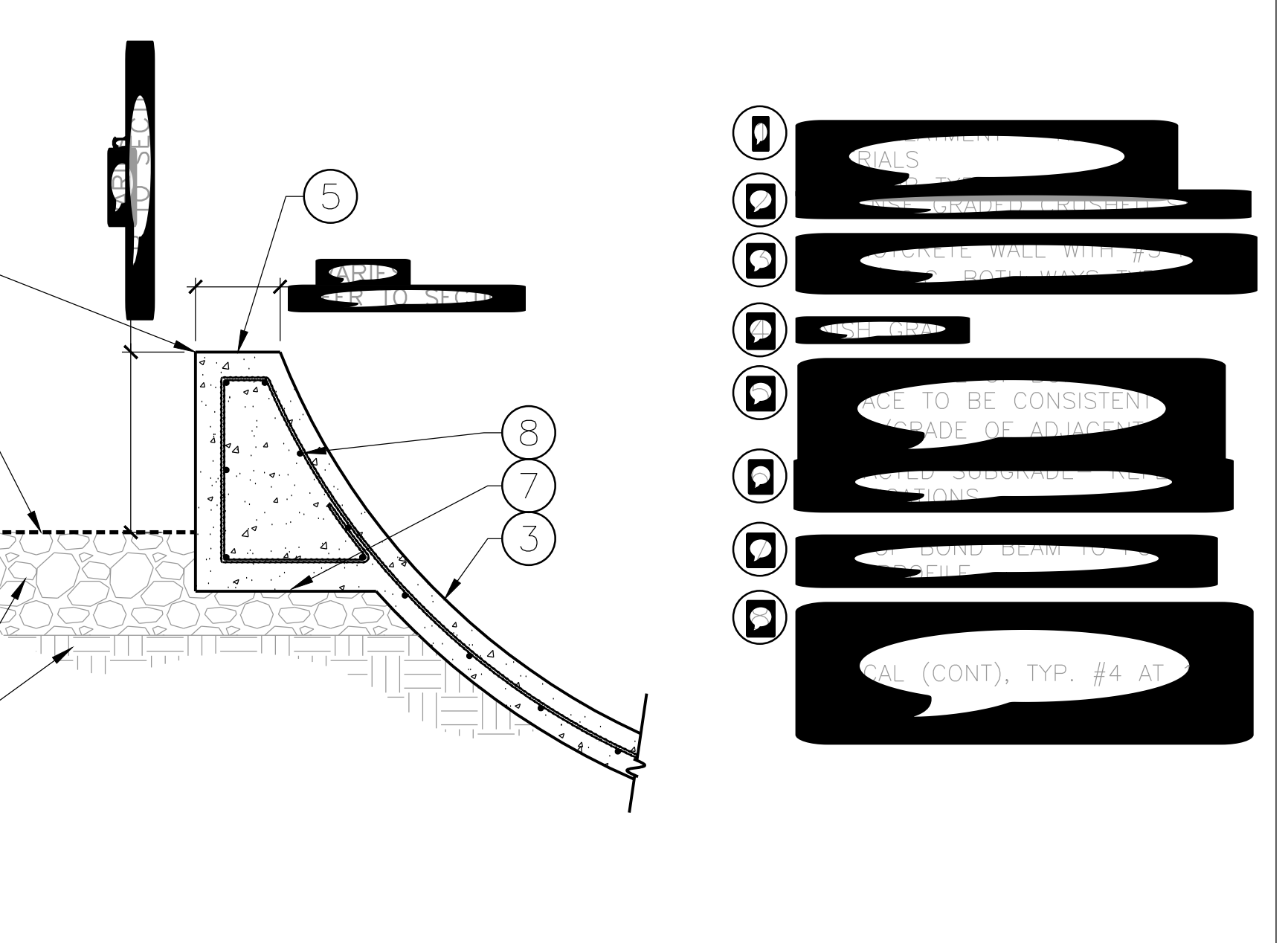

6 SHOTCRETE BERM-WALL EXTENSION

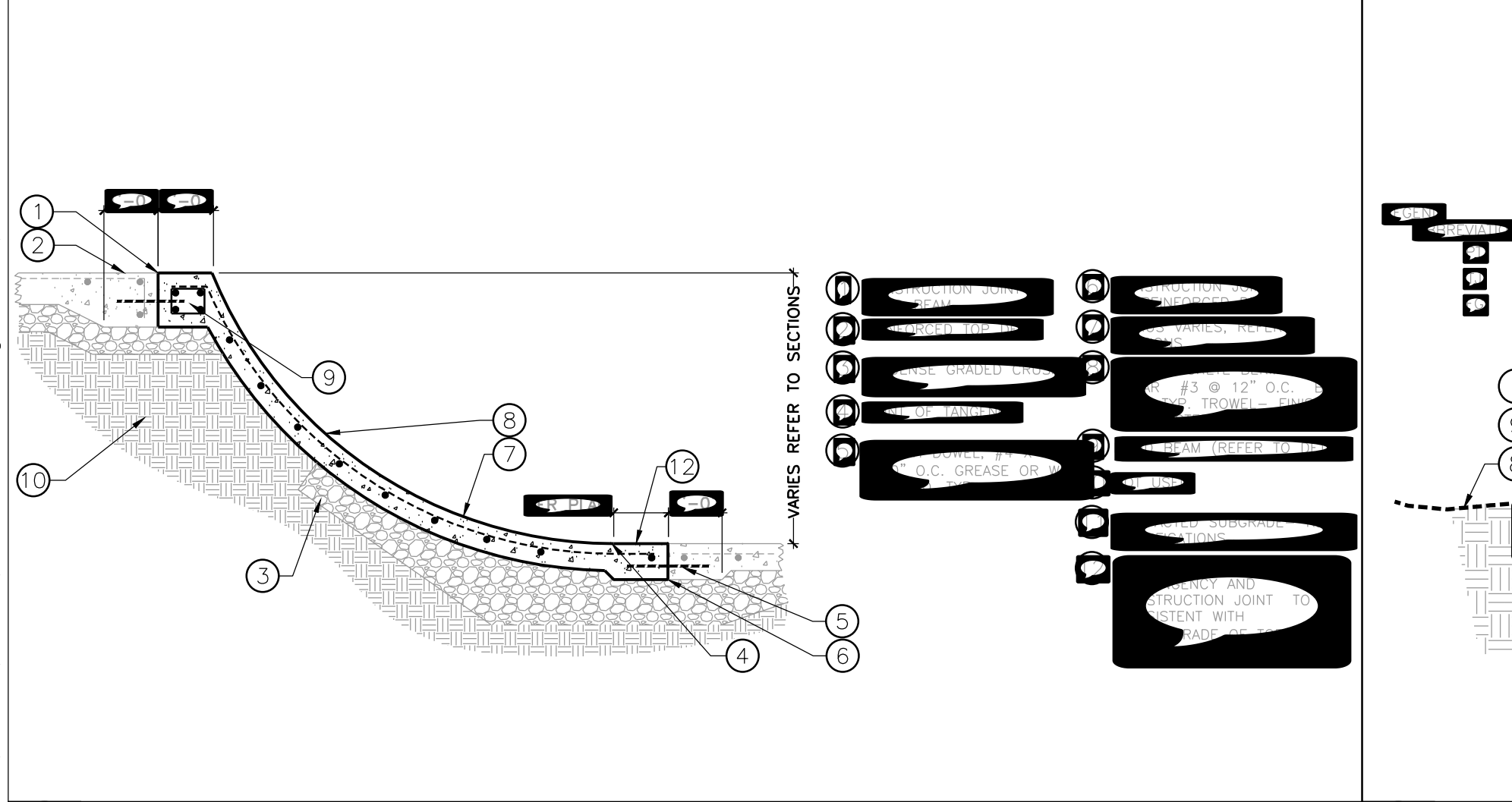

7 SHOTCRETE BERM-DETAIL

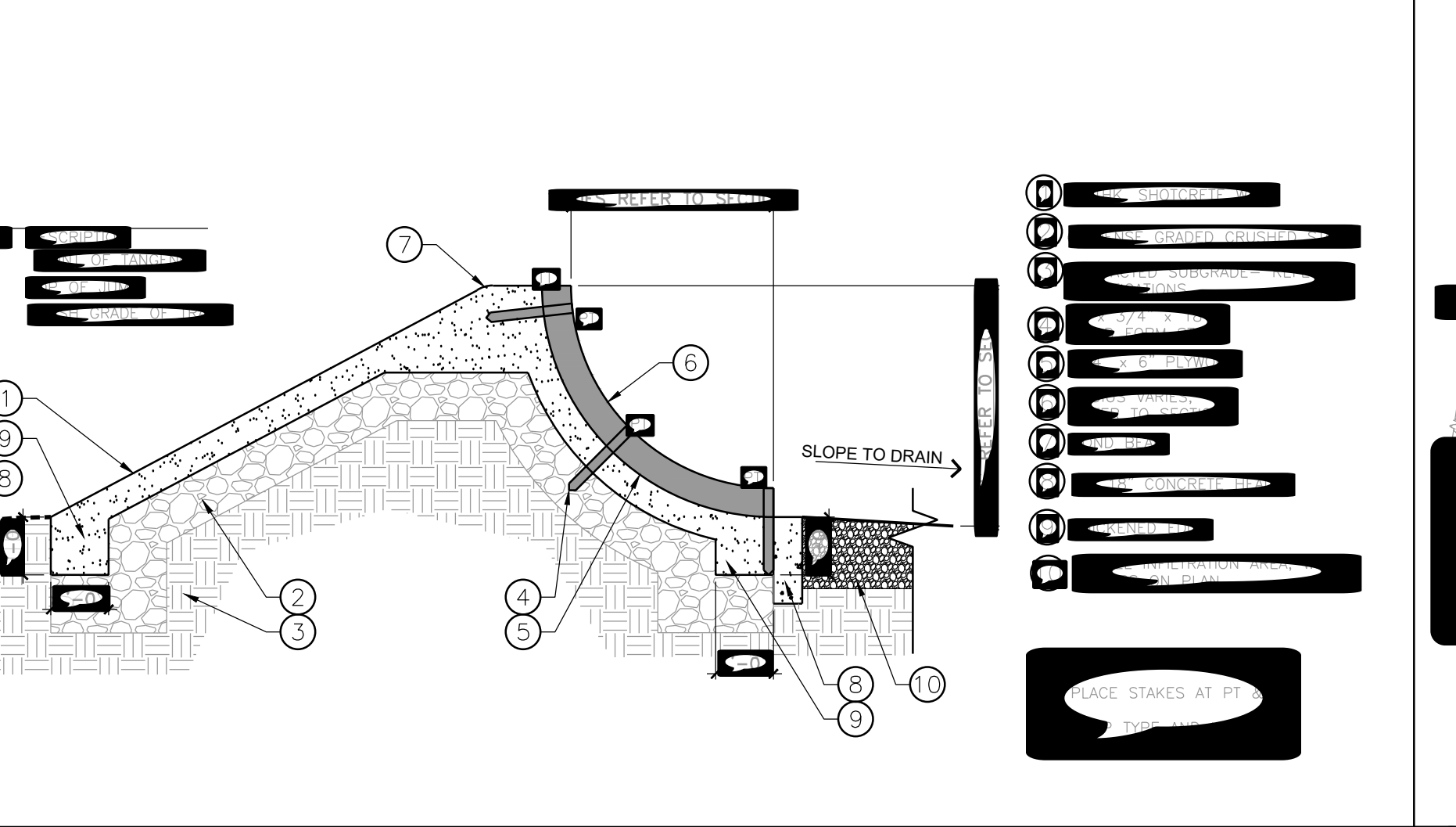

8 SHOTCRETE BERM-FORM

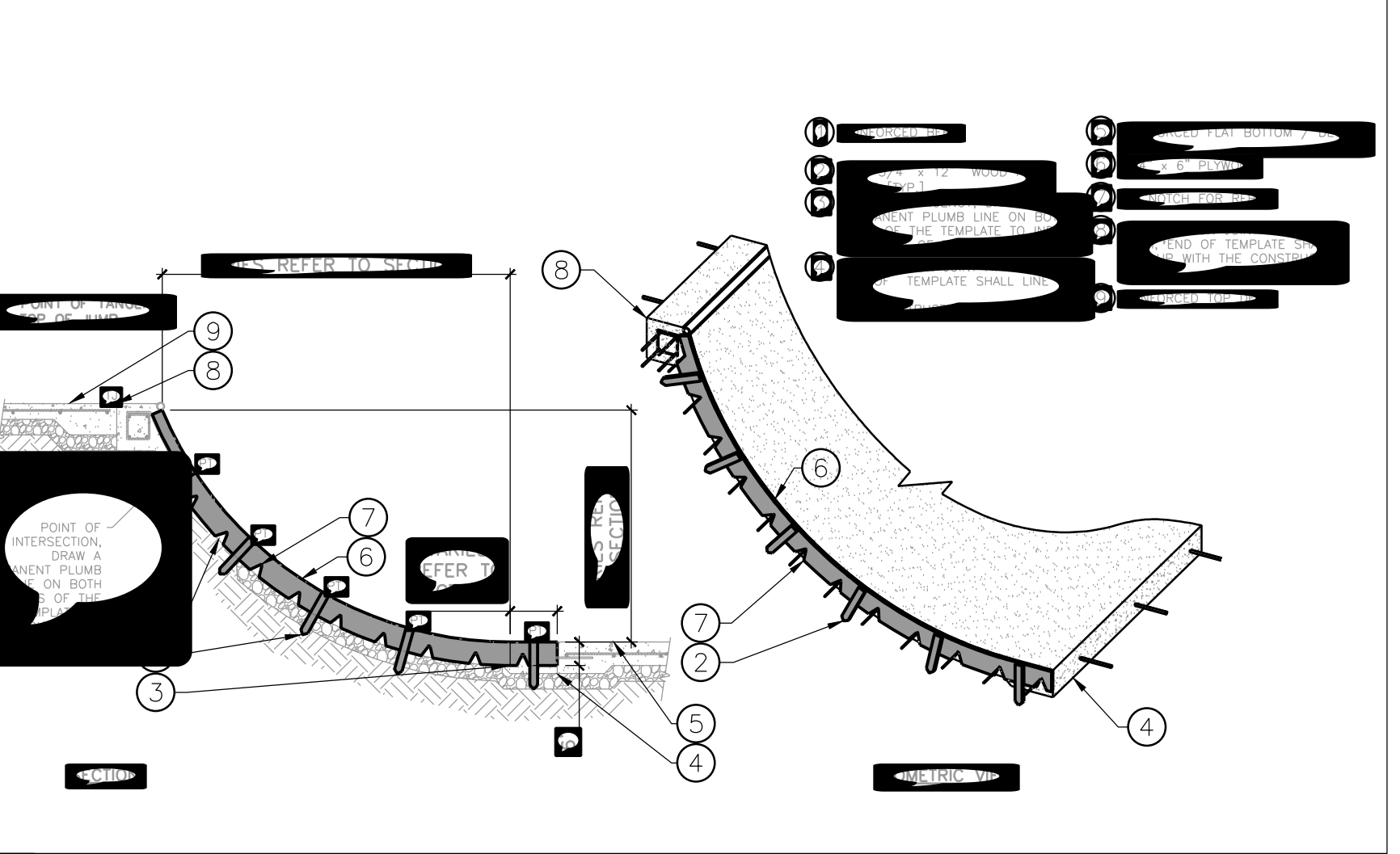

9 SHOTCRETE START-STOP FORM

ISSUED SETS	
Date	Description
01/05/2024	DD SUBMITTAL For Review Only

LANDSCAPE ARCHITECT
BENDER WELLS CLARK DESIGN
 830 N. ALAMO ST.
 SAN ANTONIO, TEXAS 78215

Landscape Architecture
Urban Design
Planning

830 North Alamo Street
 San Antonio, Texas 78215
 210-692-9221
 www.bwcdesign.com

© 2023 Bender Wells Clark Design
 All rights reserved. No part of this document may be reproduced or utilized in any form without prior written authorization of Bender Wells Clark Design.

O. P. Schnabel Bike Park
Bike Park
2022 Bond Improvements

9700 Rochelle Road
San Antonio Tx 78240

This drawing and the design was prepared specifically for this site and client and does not apply to any other projects. The reuse of this drawing in any other project is prohibited. Use of this set of drawings requires appropriate authorization from Bender Wells Clark Design.

LANDSCAPE ARCHITECT'S LICENSURE

THESE DOCUMENTS ARE INCOMPLETE AND ARE RELEASED FOR INTERIM REVIEW ONLY, AND NOT INTENDED FOR REGULATORY APPROVAL, BIDDING, PERMIT, OR CONSTRUCTION PURPOSES.

Drawn By: MM/ MJ Checked By: MM

SHEET TITLE & NUMBER:
 FLOW LINE DETAILS

BP-05.05

Date: Jan 05, 2024, 2:33pm User ID: Mitch
 File: C:\Users\Mitch\actionsportsdesign.com\PROJECTS - Documents\TX-San Antonio-OP Schnabel Bike Park-23-050-BP\04-Construction Documents\Sheet Files\BT-06.01-SKILLS COURSE DETAILS.dwg

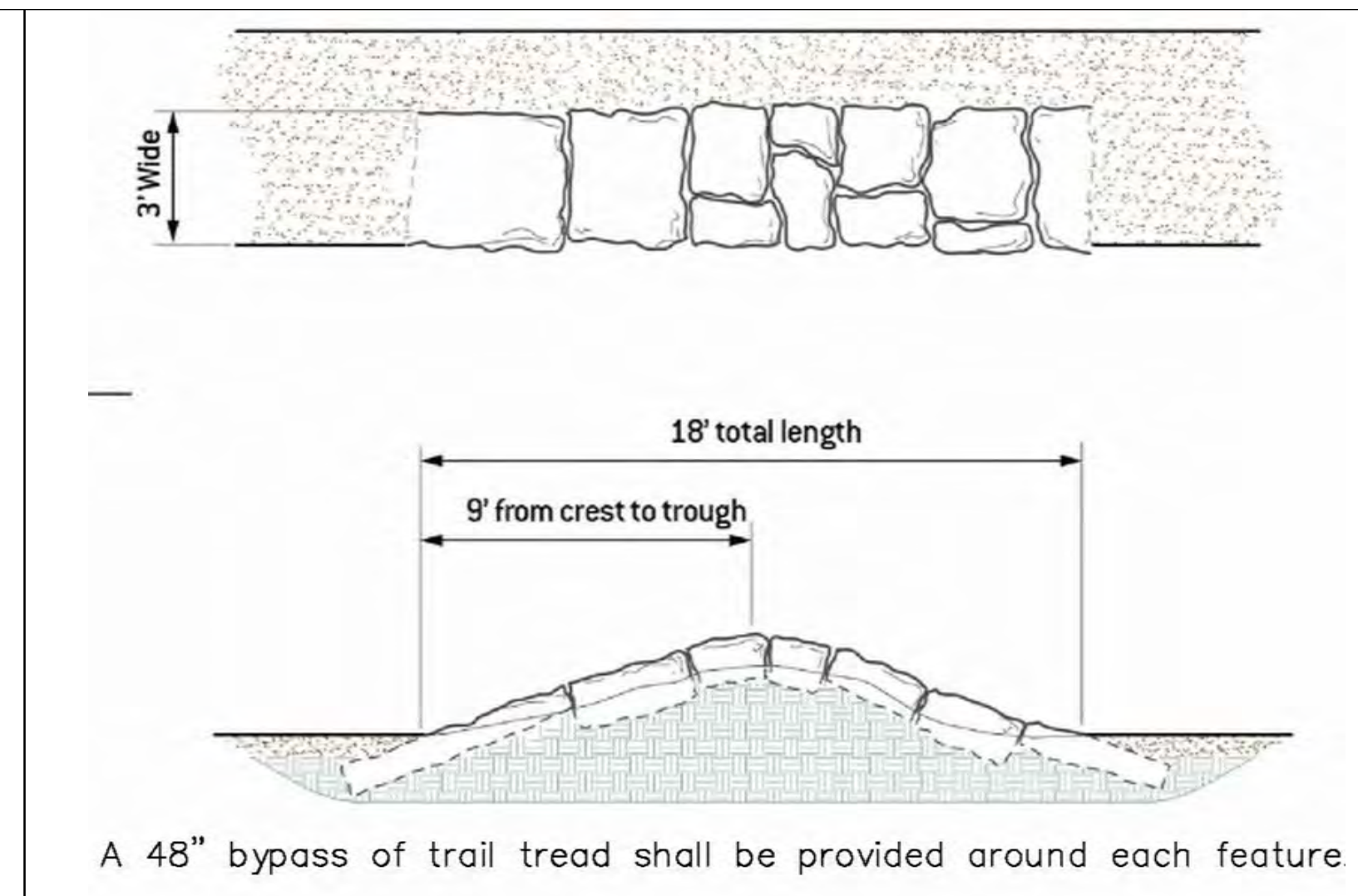
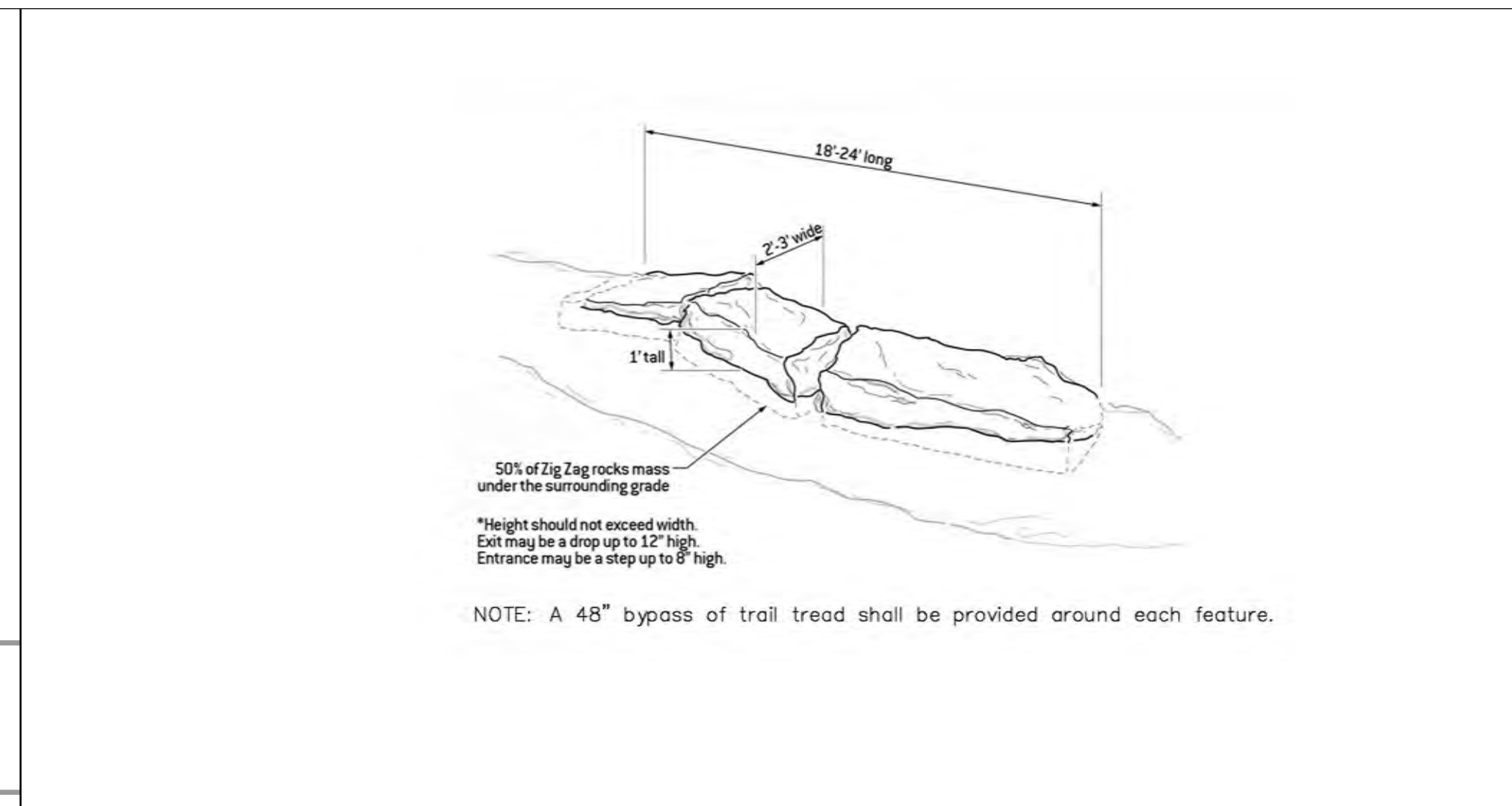
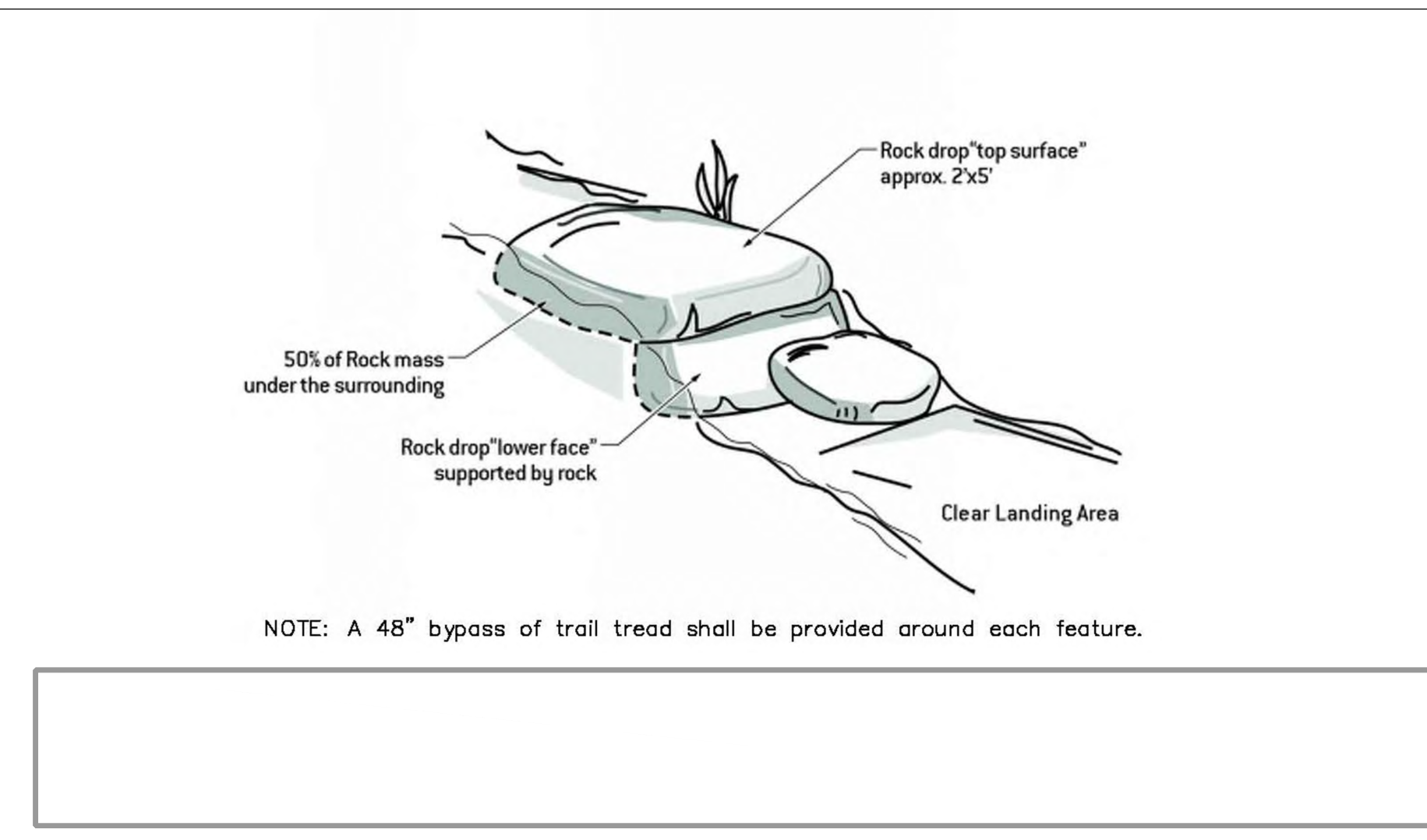

1 ROCK DROP

2 ROCK ZIG ZAG

3 ROCK ROLLER

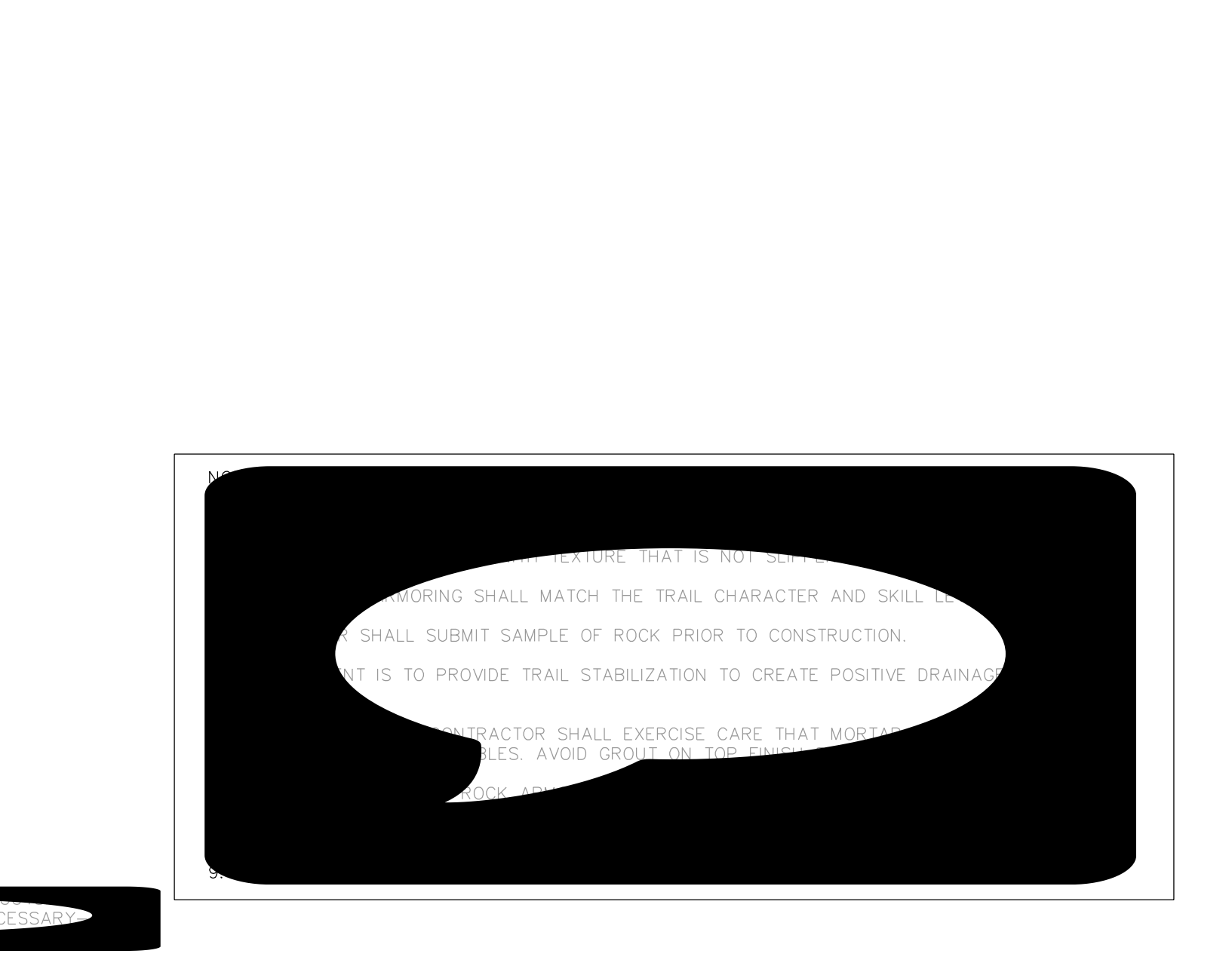
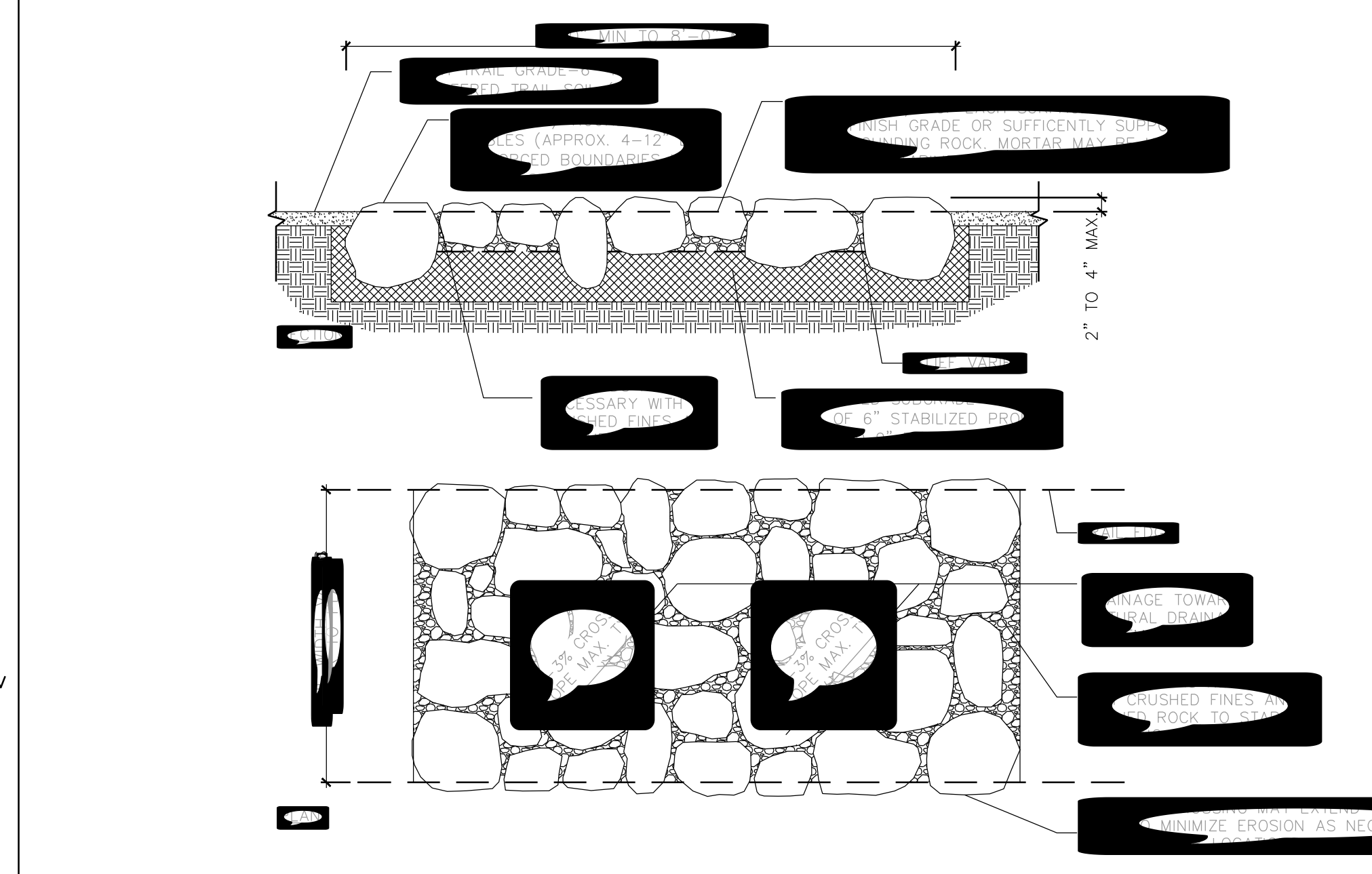
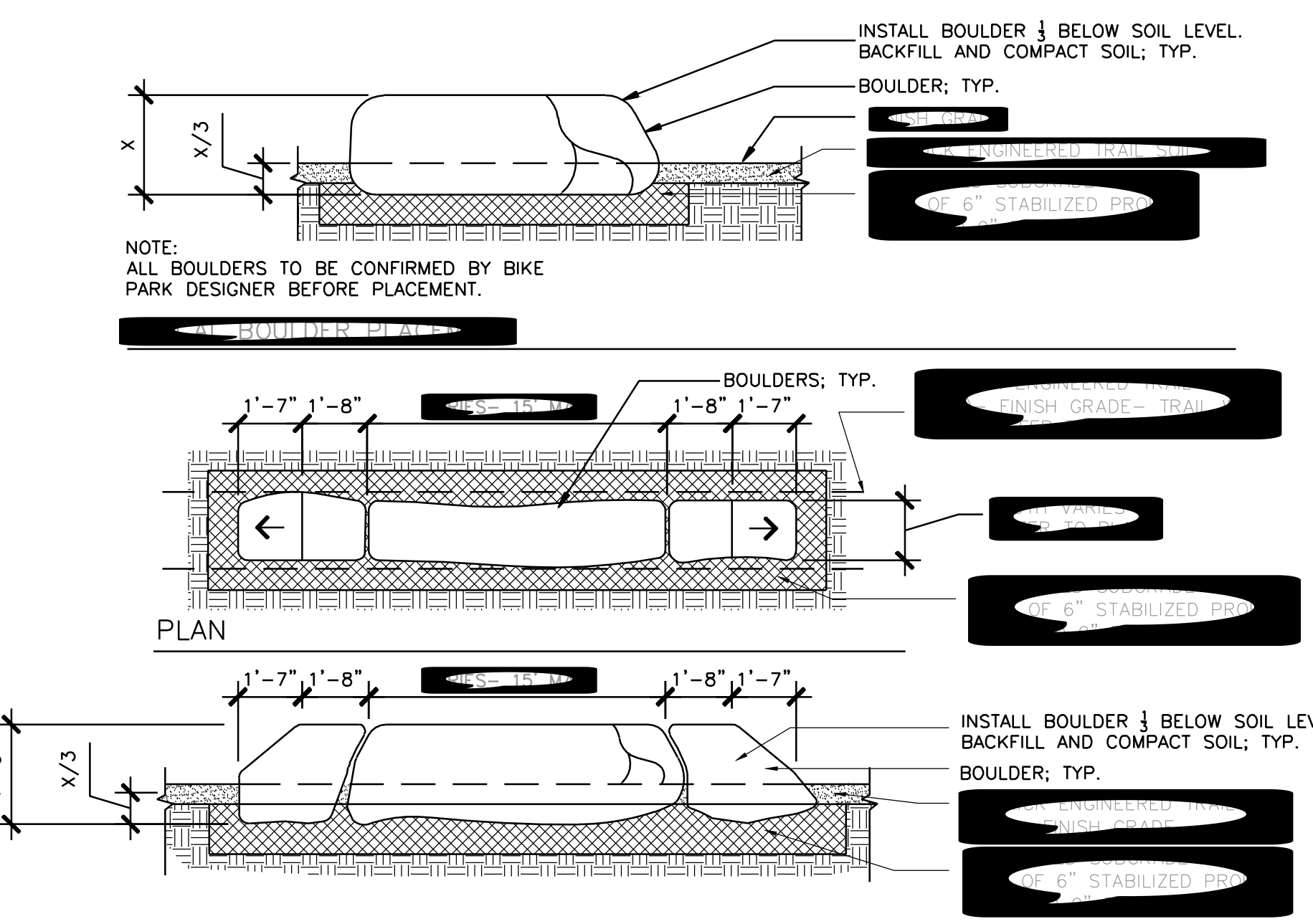

4 BOULDER/ ROCK RIDGE

5 ROCK GARDEN/ DRAINAGE CROSSING

6 BOULDER PLACEMENT

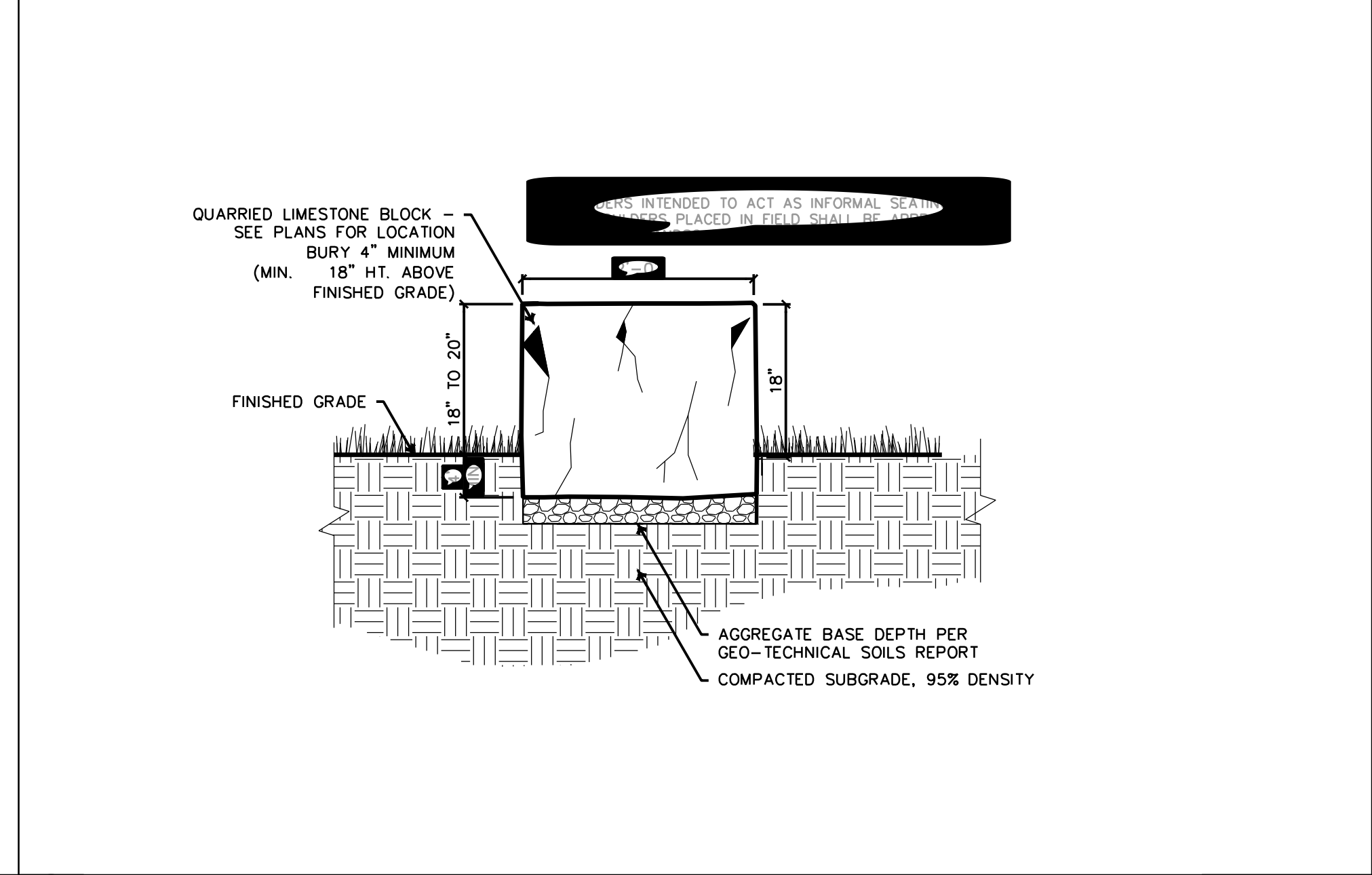
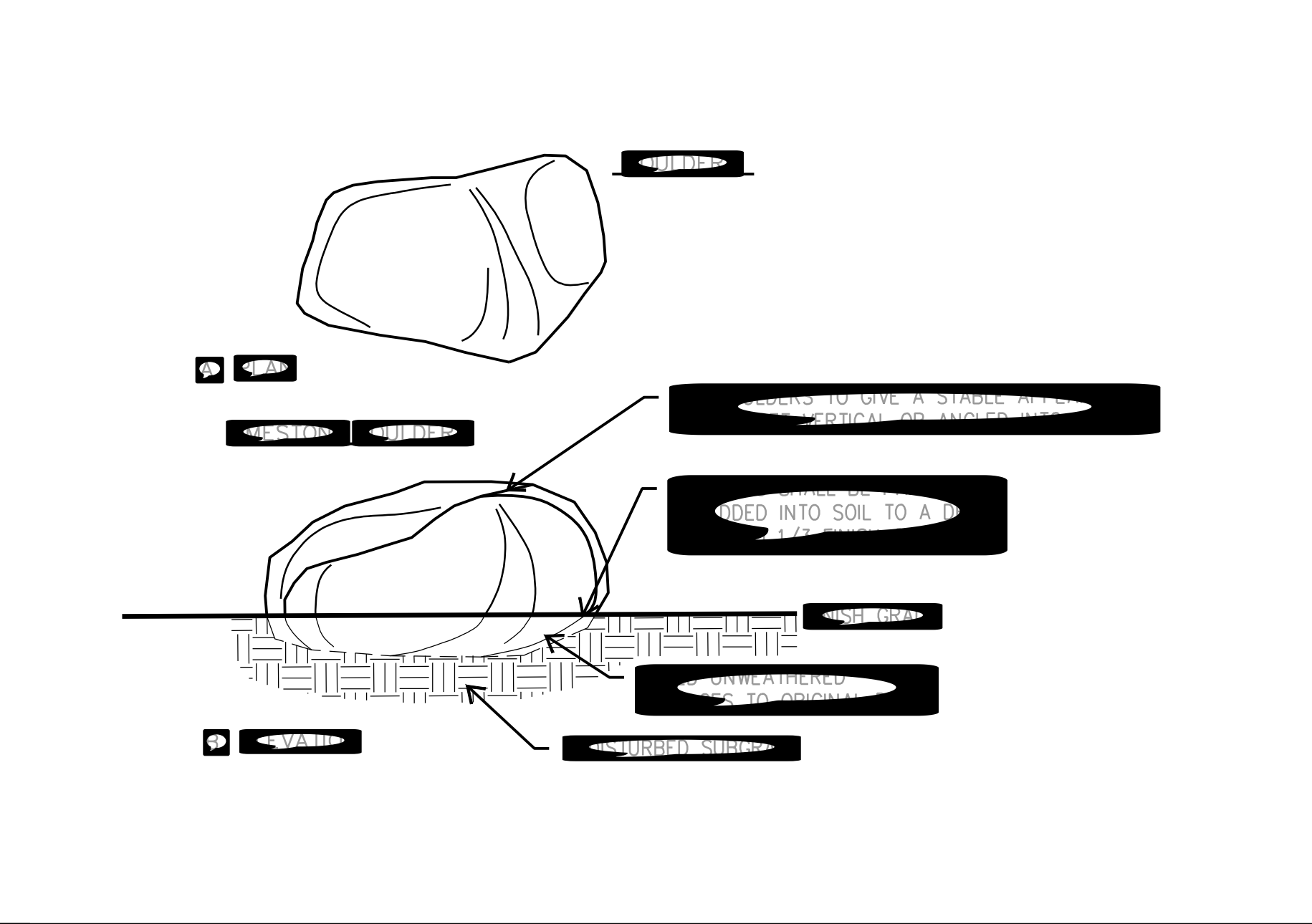

7 LIMESTONE BLOCK SEATWALL

8 SPLIT RAIL FENCING

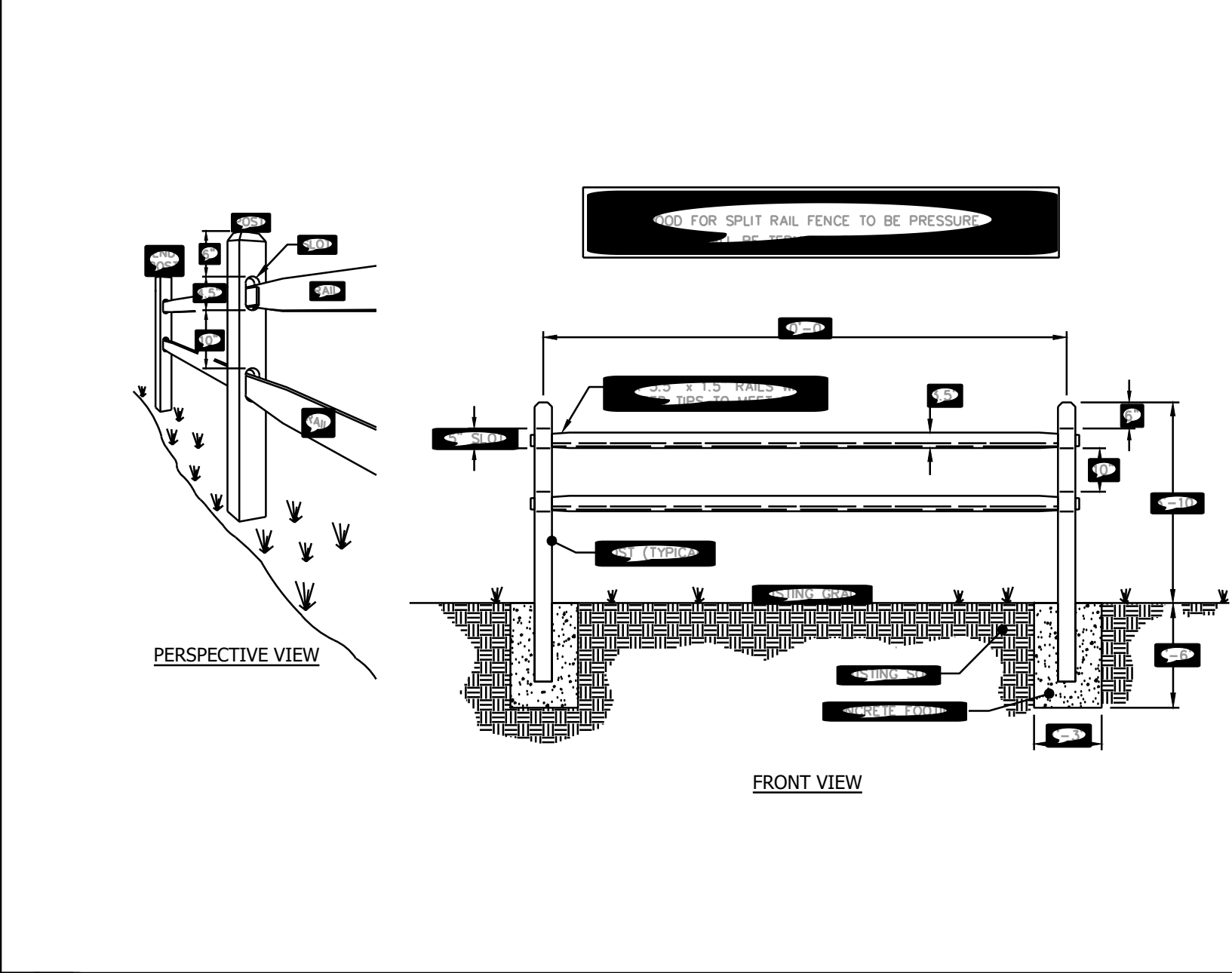

9 BARRIER WALL

ISSUED SETS	
Date	Description
01/05/2024	DD SUBMITTAL For Review Only

LANDSCAPE ARCHITECT
BENDER WELLS CLARK DESIGN
 830 N. ALAMO ST.
 SAN ANTONIO, TEXAS 78215

Landscapes Architecture
Urban Design
Planning

830 North Alamo Street
 San Antonio, Texas 78215
 210-692-9221
 www.bwcdesign.com

© 2023 Bender Wells Clark Design
 All rights reserved. No part of this document may be reproduced or utilized in any form without prior written authorization of Bender Wells Clark Design.

O. P. Schnabel Bike Park
Bike Park
2022 Bond Improvements

9700 Rochelle Road
San Antonio Tx 78240

This drawing and the design were prepared specifically for this site and client and does not apply to any other projects. The reuse of this drawing for any other project is prohibited. Use of this set of drawings requires appropriate authorization from Bender Wells Clark Design.

LANDSCAPE ARCHITECT'S LICENSURE

THESE DOCUMENTS ARE INCOMPLETE AND ARE RELEASED FOR INTERIM REVIEW ONLY, AND NOT INTENDED FOR REGULATORY APPROVAL, BIDDING, PERMIT, OR CONSTRUCTION PURPOSES.

Drawn By : MM/ MJ Checked By : MM

SHEET TITLE & NUMBER:
SKILLS COURSE DETAILS

BP-06.01

Date: Jan 05, 2024, 2:34pm User ID: Mitch
 File: C:\Users\Mitch\actionsportsdesign.com\PROJECTS - Documents\TX-San Antonio-OP Schnabel Bike Park-23-050-BP-04-Construction Documents\Sheet Files\BT-06.01-SKILLS COURSE DETAILS.dwg

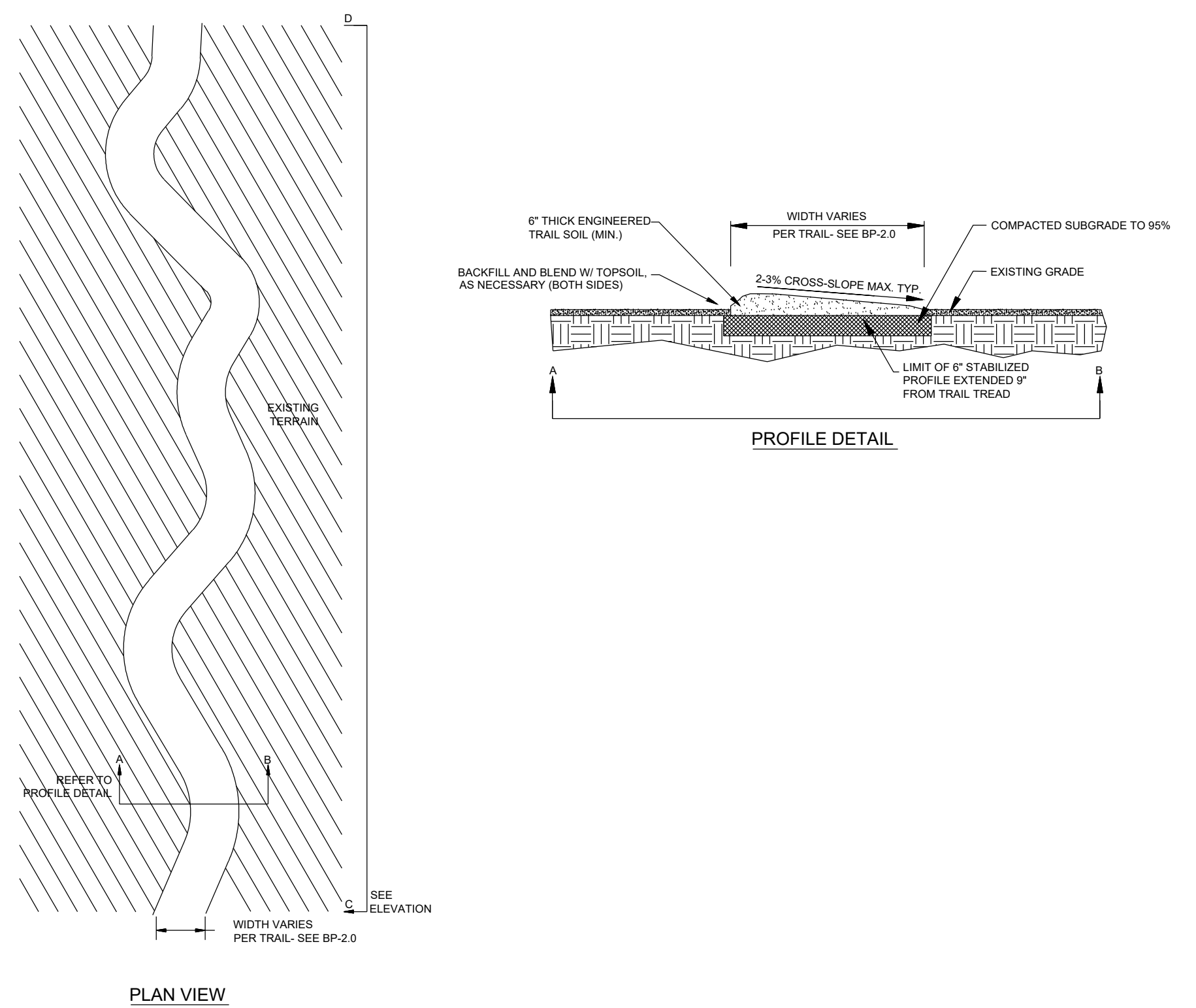

PLAN VIEW

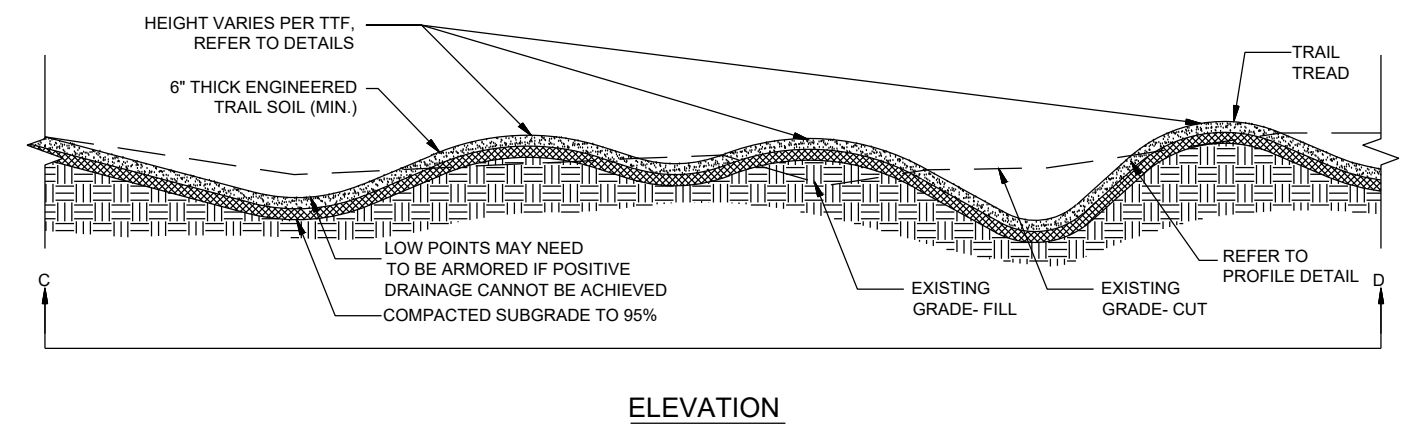

ELEVATION

- NOTES:**
- TRAIL SHALL HAVE GENTLE TURNS WITH RANDOMLY VARYING RADII.
 - TRAIL TREAD SHALL BE SMOOTH, WITH NO ROCKS PROTRUDING MORE THAN 3".
 - CORRIDOR SHALL BE A MINIMUM OF 10' IN WIDTH AND CLEAR OF HOLES AND PROTRUDING OBJECTS. TRAIL TREAD DOES NOT NEED TO BE CENTERED IN CORRIDOR.
 - TO FACILITATE OFF-TRAIL PASSING, SHOULDERS OF TRAIL SHOULD NOT DROP OFF ABRUPTLY, BUT ONE SIDE MAY.
 - TURNS SHOULD BE CAMBERED/ BANKED.
 - TRAILSIDE OBJECTS (EXISTING OR IMPORTED) SHOULD BE PLACED AT THE INSIDE APEX OF TURNS, AS NEEDED TO PREVENT OR REDUCE SHORT CUTTING.
 - TRAIL SHALL HAVE CONSTANT GENTLE VERTICAL UNDULATIONS OF RANDOMLY VARYING HEIGHTS.
 - TO ENSURE DRAINAGE ON FLAT GROUND, THE TREAD SHOULD BE CROSSLOPED, NOT CROWNED. IN MOST INSTANCES TOWARDS THE INSIDE OF A TURN. GREATER CROSSLOPES MAY BE REQUIRED IN LARGER TURNS. CROSSLOPE IS NOT NEEDED ON THE ASCENDING OR DESCENDING FACES OF UNDULATIONS.

TYPICAL TRAIL (FLAT)

1 TYPICAL TRAIL-FLAT

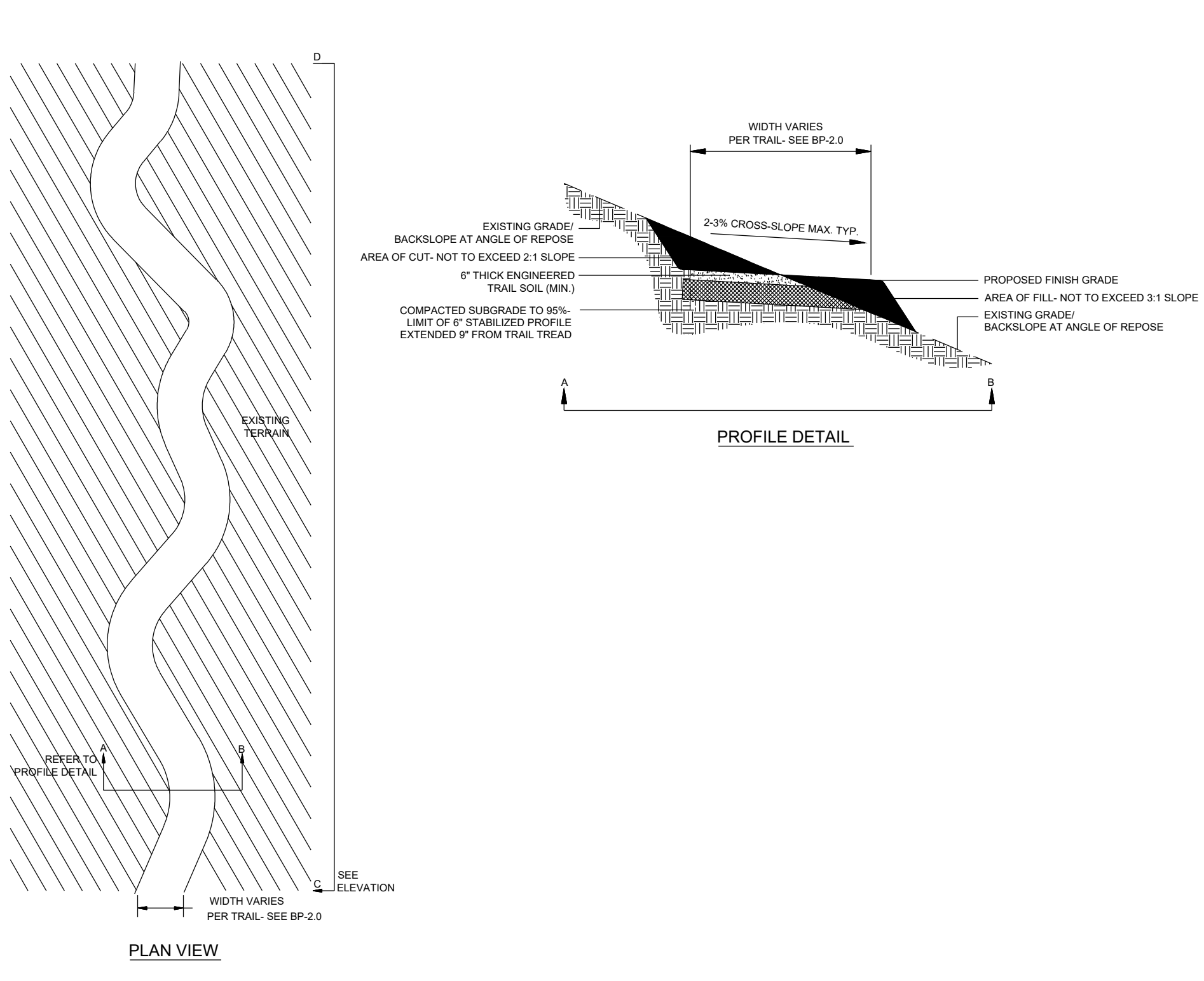

PLAN VIEW

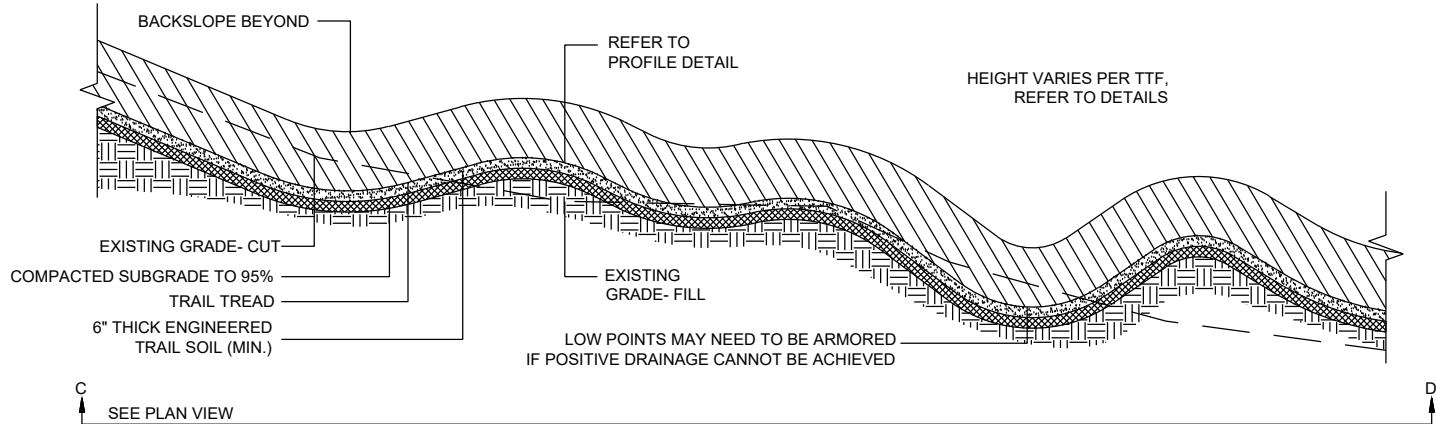

ELEVATION

- NOTES:**
- TRAIL SHALL HAVE EXAGGERATED TURNS WITH RANDOMLY VARYING RADII.
 - TRAIL TREAD CAN BE ROUGH, WITH ROCKS UP TO 8".
 - CORRIDOR SHALL BE A MINIMUM OF 10' IN WIDTH AND CLEAR OF HOLES AND PROTRUDING OBJECTS. TRAIL TREAD DOES NOT NEED TO BE CENTERED IN CORRIDOR.
 - TRAILSIDE OBJECTS (EXISTING OR IMPORTED) SHOULD BE PLACED AT THE INSIDE APEX OF TURNS, AS NEEDED TO PREVENT OR REDUCE SHORT CUTTING.
 - TRAIL SHALL HAVE EXAGGERATED UNDULATIONS WITH RANDOMLY VARYING HEIGHTS.
 - IN SLOPED TREAD MAY BE DESIRABLE IN LOCATIONS AND IS ACCEPTABLE IF PROPER DRAINAGE CONTROL (E.G., GRADE REVERSALS, BASINS) IS EMPLOYED.
 - TURNS SHALL BE CAMBERED/ BANKED.

TYPICAL TRAIL (SIDEHILL)

2 TYPICAL TRAIL-SIDEHILL

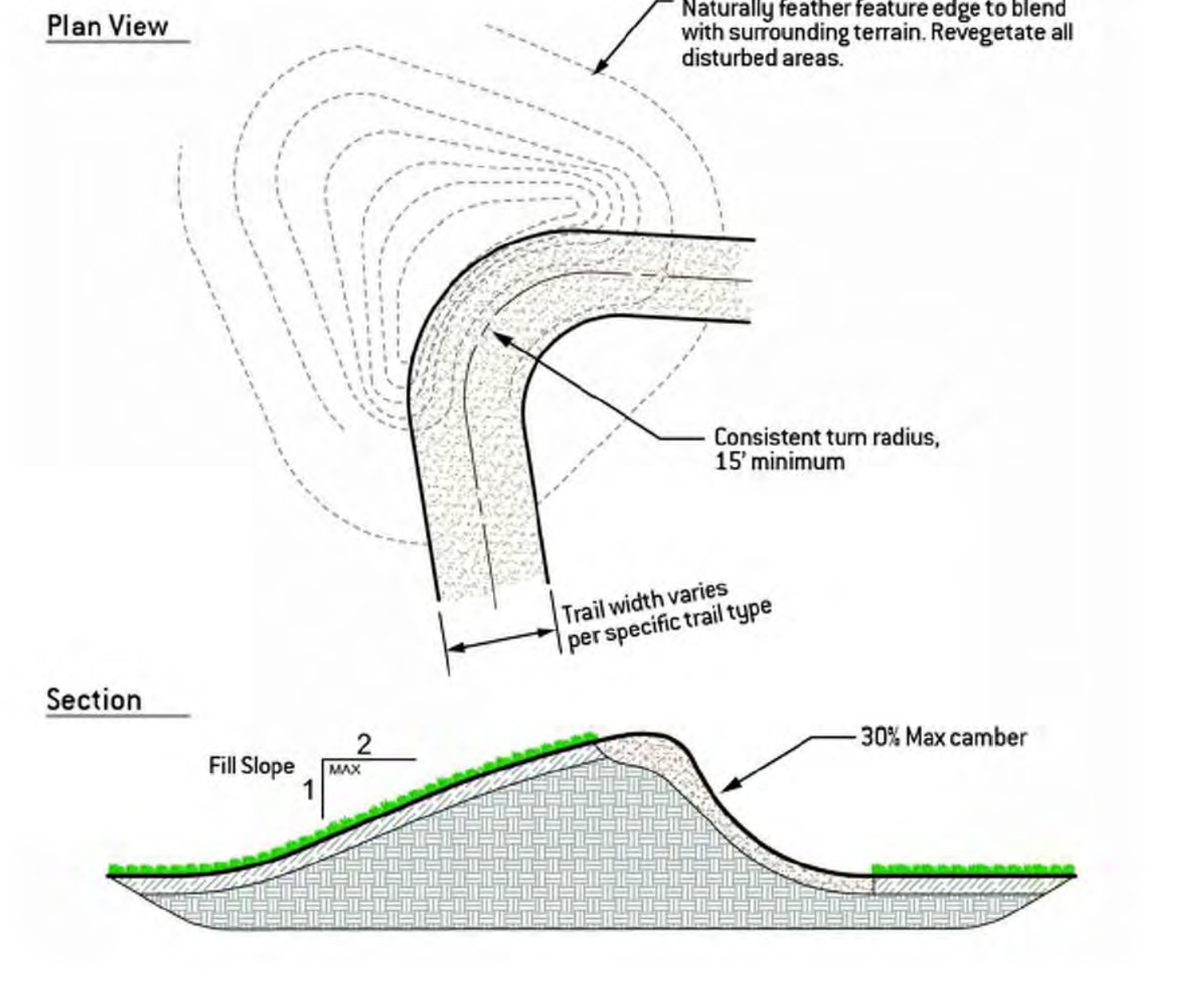

Plan View

Section

3 BERMED TURN-TYPICAL

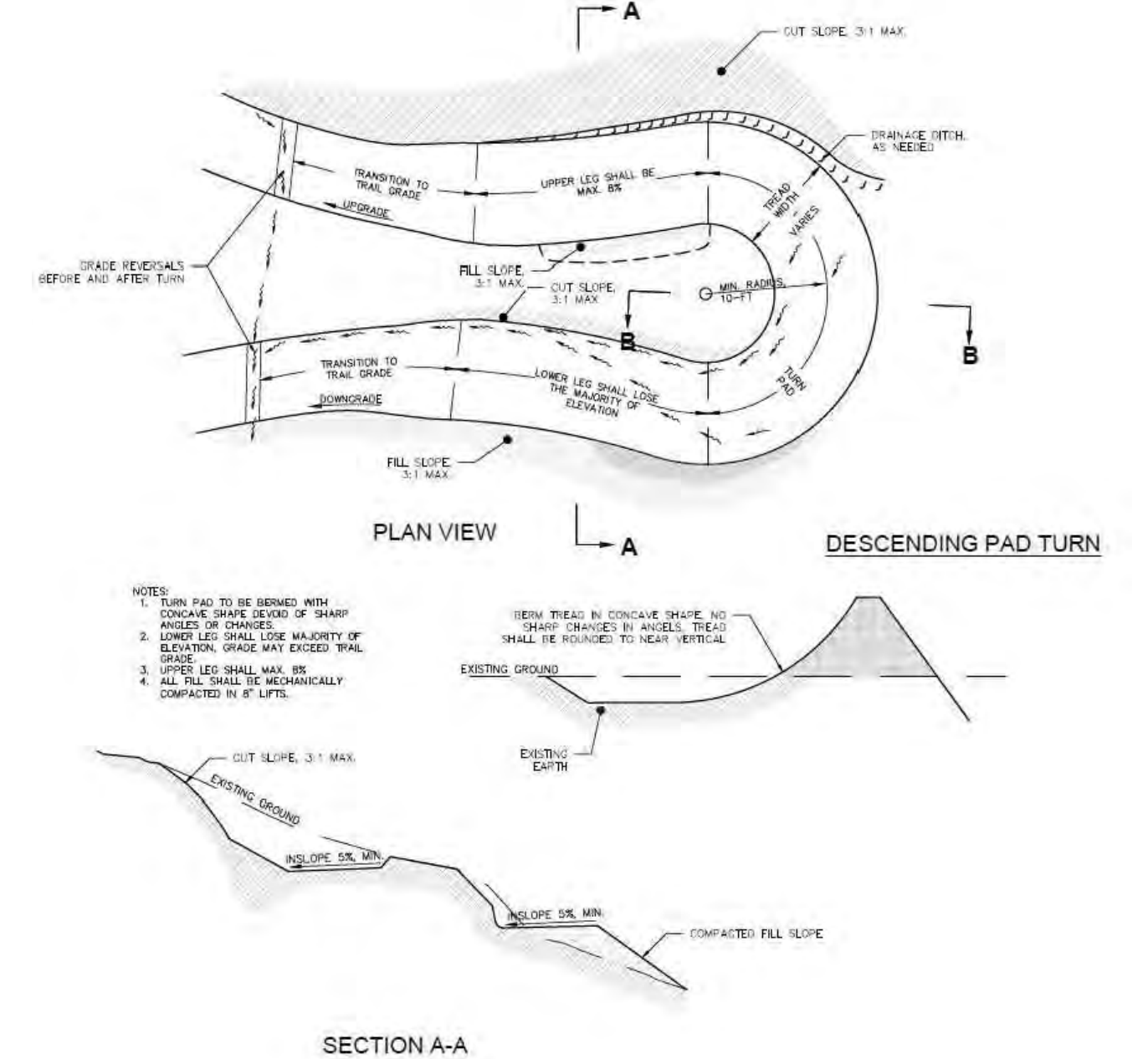

PLAN VIEW

SECTION A-A

4 DECENDING PAD TURN-TYPICAL

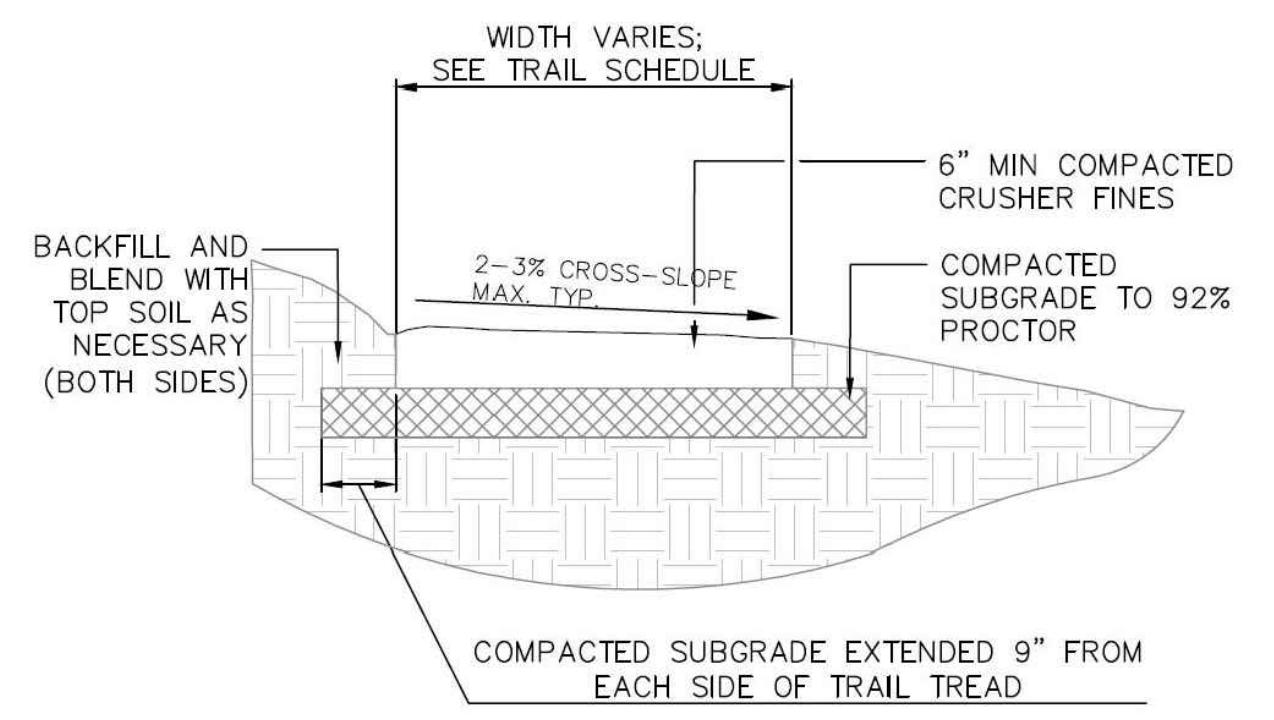

5 CRUSHER FINE TRAIL-TYPICAL

ISSUED SETS	
Date	Description
01/05/2024	DD SUBMITTAL For Review Only

REVISIONS		
No.	Date	Description

LANDSCAPE ARCHITECT
BENDER WELLS CLARK DESIGN
 830 N. ALAMO ST.
 SAN ANTONIO, TEXAS 78215

Landscape Architecture
Urban Design
Planning

830 N. Alamo Street
 San Antonio, Texas 78215
 210-692-9221
 www.bwcdesign.com

© 2023 Bender Wells Clark Design
 All rights reserved. No part of this document may be reproduced or utilized in any form without prior written authorization of Bender Wells Clark Design.

O. P. Schnabel Bike Park
Bike Park
2022 Bond Improvements

9700 Rochelle Road
 San Antonio Tx 78240

This drawing and the design work prepared hereon are the property of Bender Wells Clark Design. The reproduction or use of this drawing in any other project without the written authorization of Bender Wells Clark Design is prohibited.

LANDSCAPE ARCHITECT'S LICENSURE

THESE DOCUMENTS ARE INCOMPLETE AND ARE RELEASED FOR INTERIM REVIEW ONLY, AND NOT INTENDED FOR REGULATORY APPROVAL, BIDDING, PERMIT, OR CONSTRUCTION PURPOSES.

Drawn By : MM/ MJ Checked By : MM

SHEET TITLE & NUMBER:
 SKILLS COURSE
 DETAILS

BP-06.02

Date: Jan 05, 2024, 2:35pm User ID: Mitch
 File: C:\Users\Mitch\actionsportsdesign.com\PROJECTS - Documents\TX-San Antonio-OP Schnabel Bike Park-23-050-BP-04-Construction Documents\Sheet Files\BT-06.01-SKILLS COURSE DETAILS.dwg

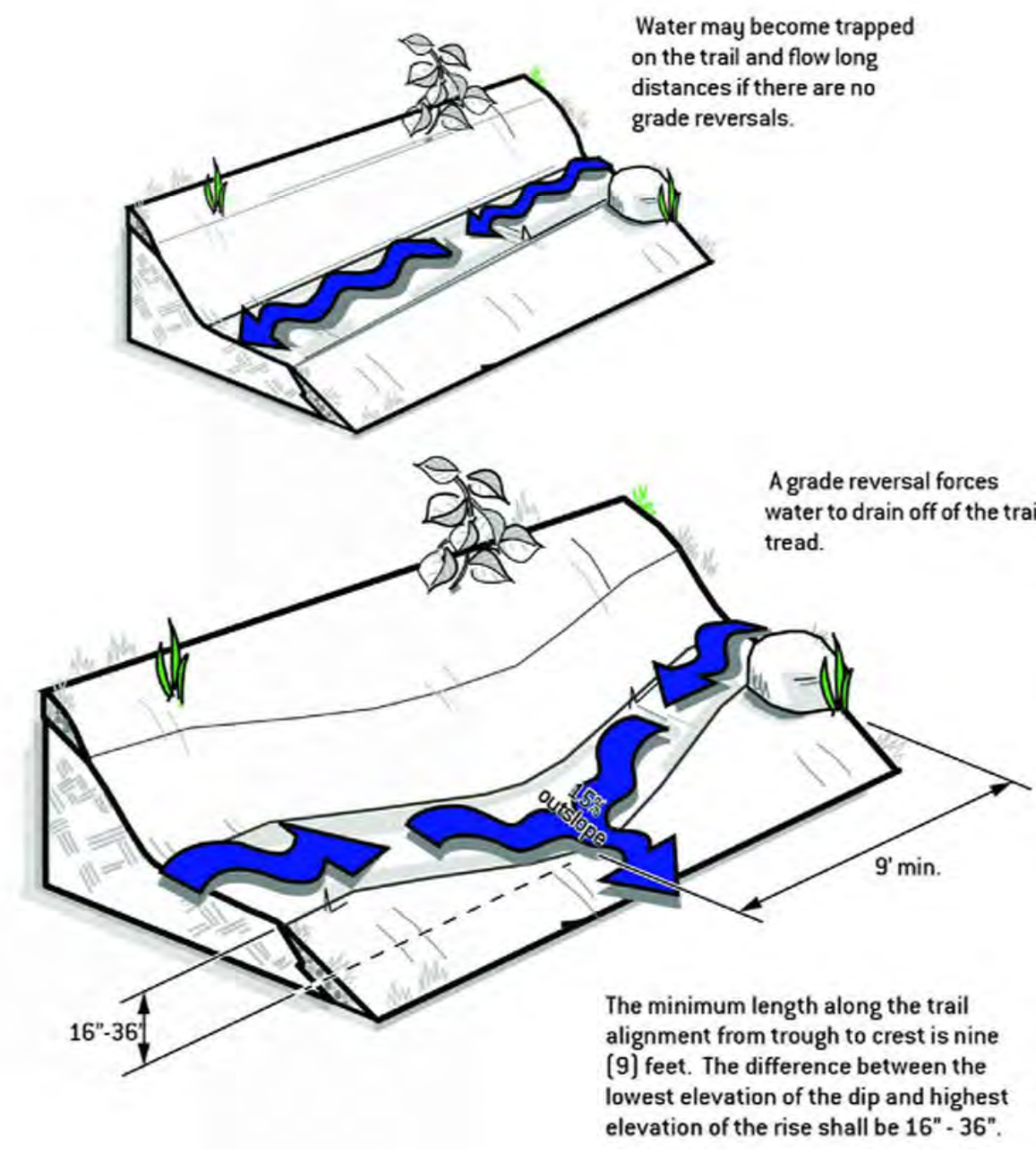

1 GRADE REVERSAL-TYPICAL

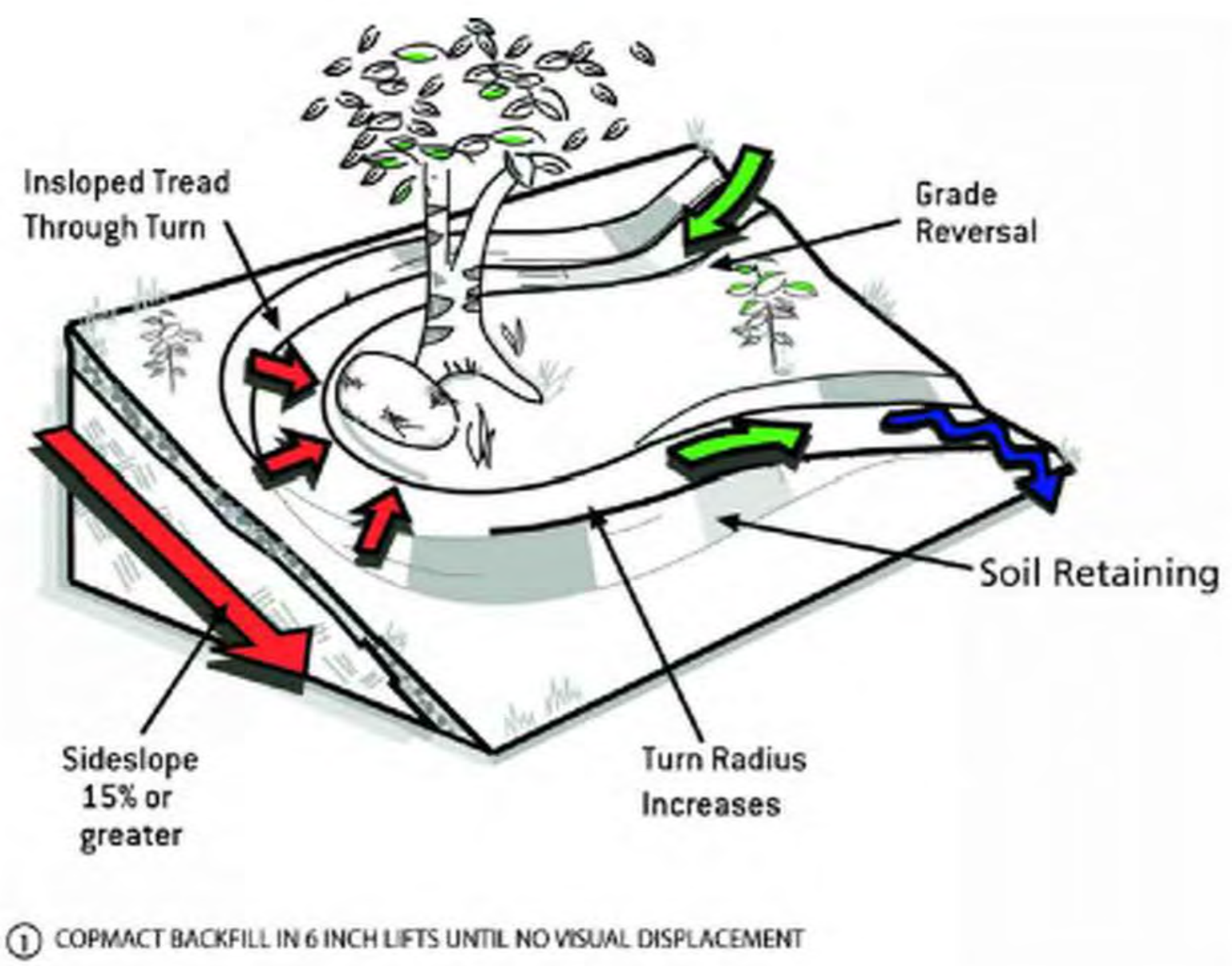

2 ELEVATED PLATFORM RETURN-TYPICAL

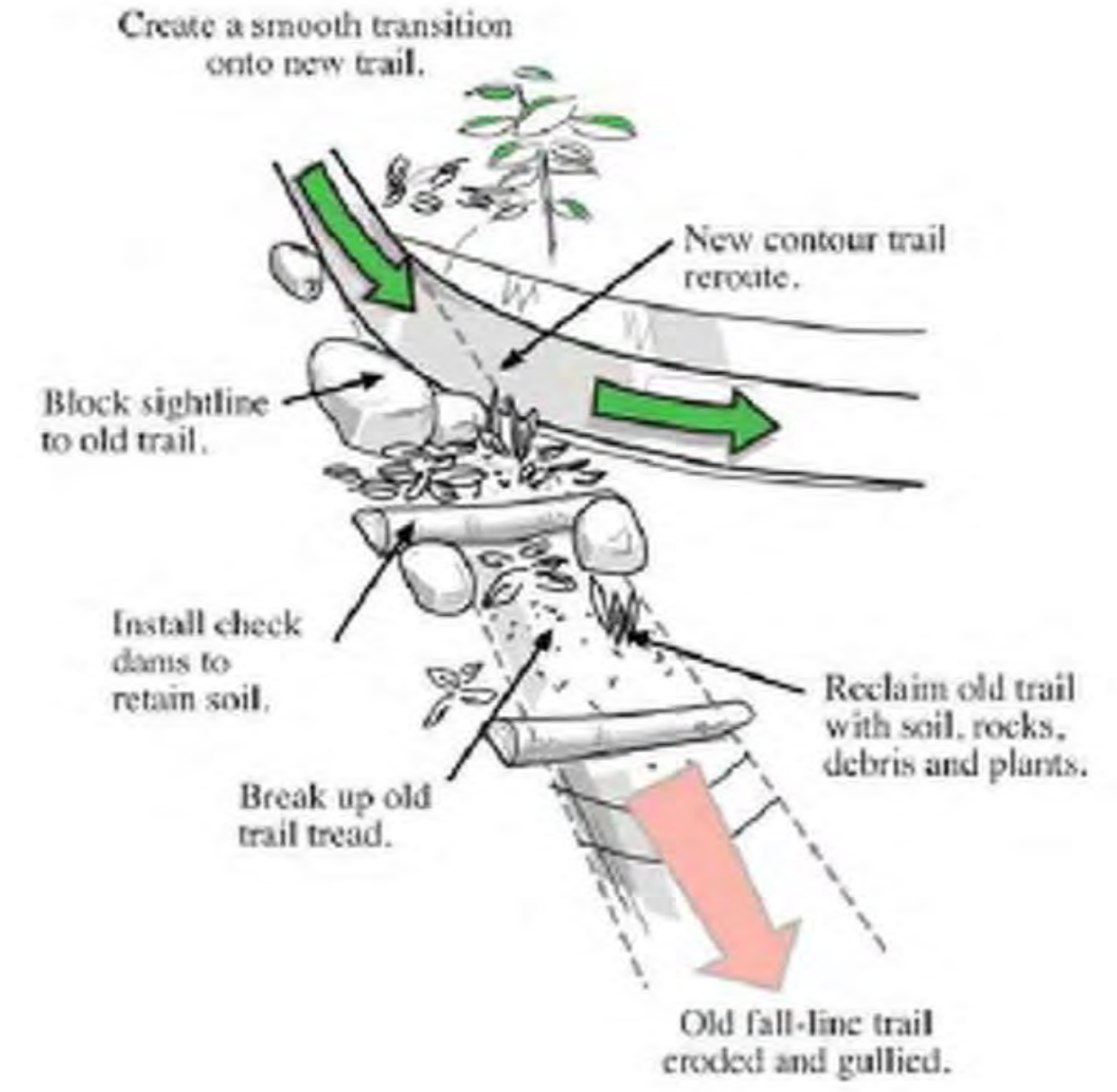

3 DECOMMISSIONED TRAIL SEGMENT

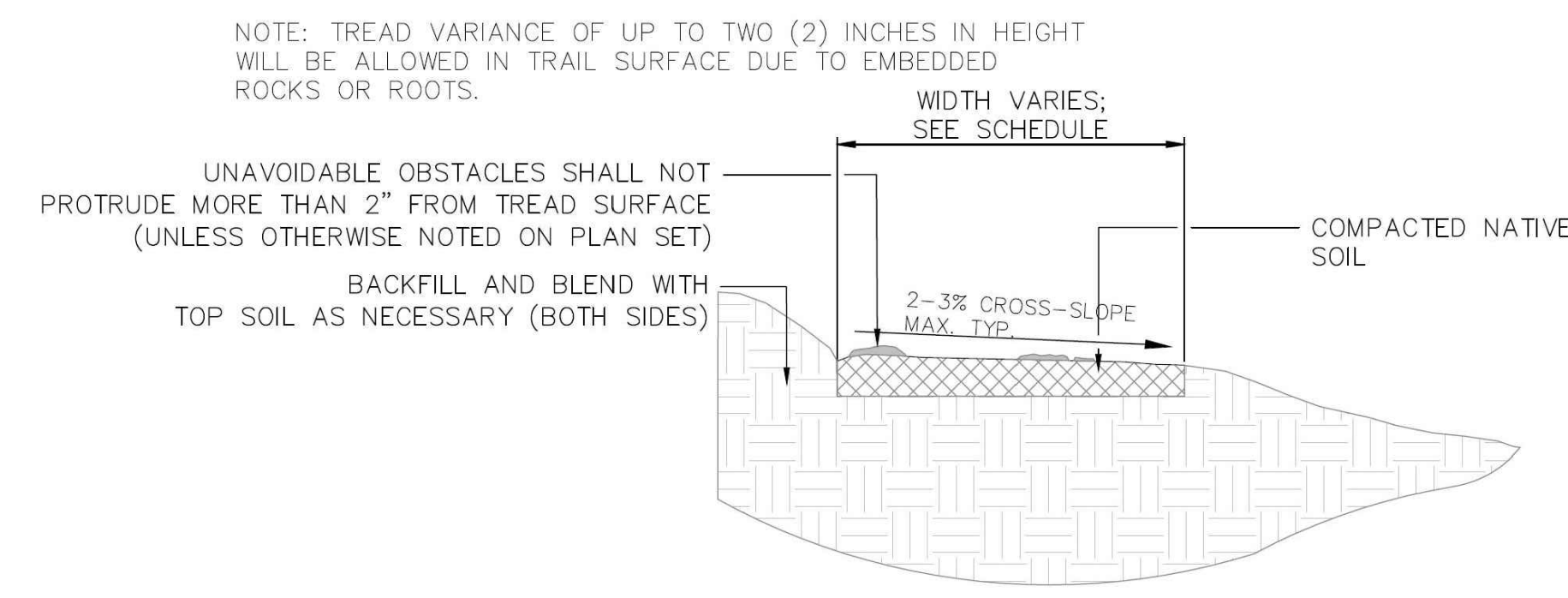

4 SINGLETRACK TRAIL SECTION-TYPICAL

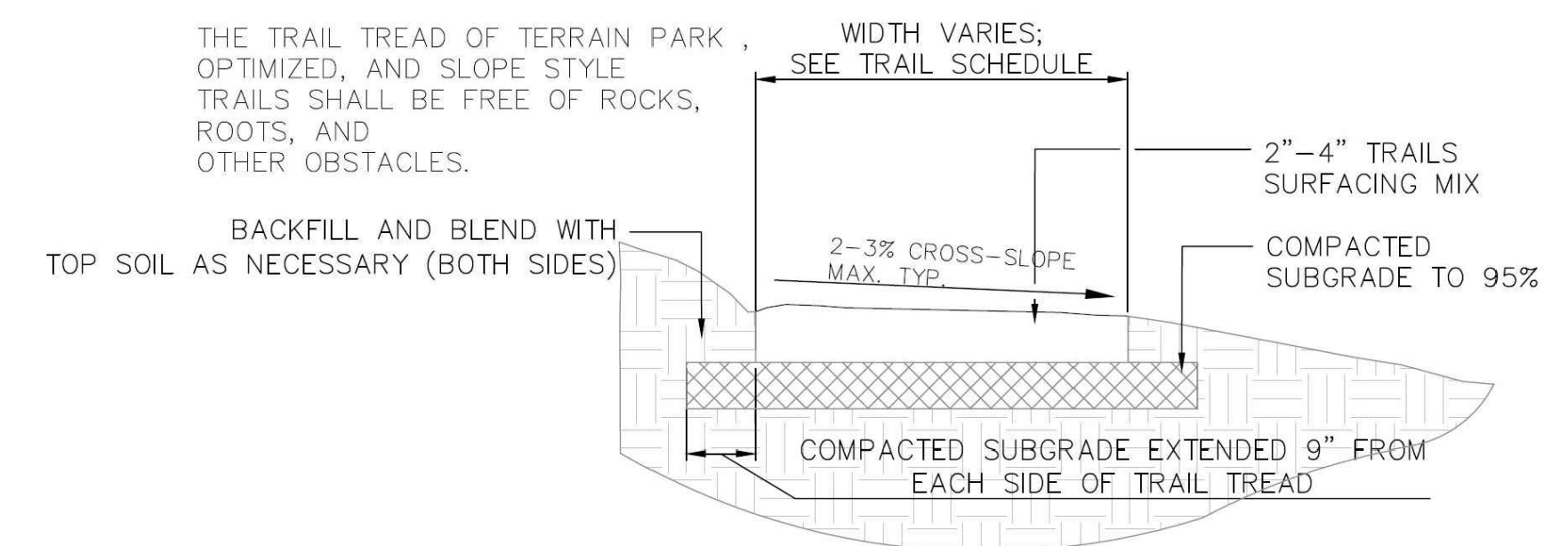

5 OPTIMIZED TRAIL SECTION-TYPICAL

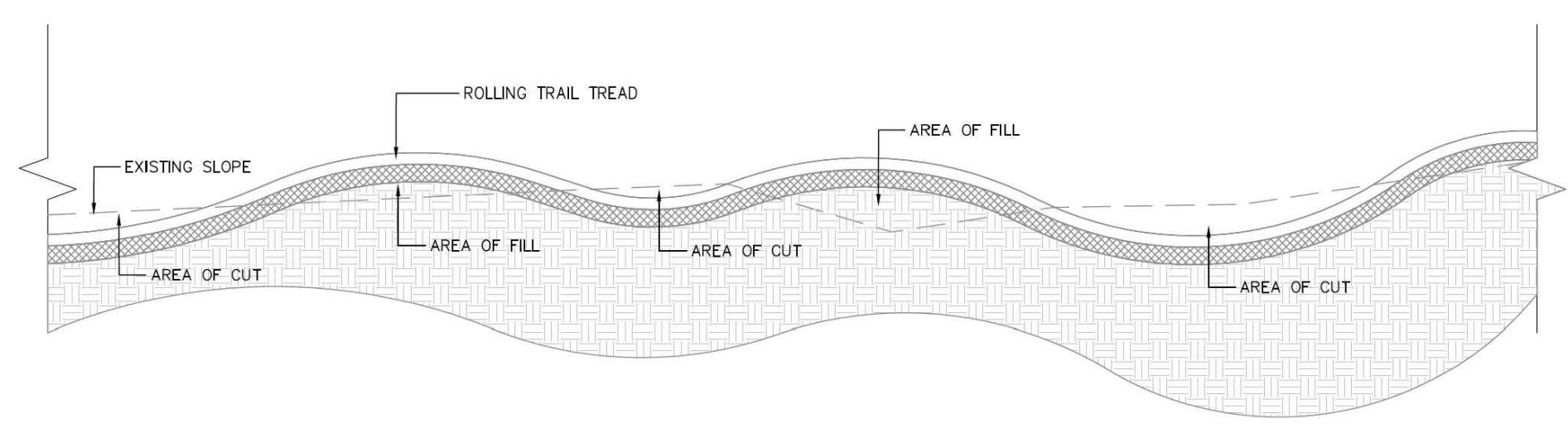

6 OPTIMIZED TRAIL SECTION-TYPICAL

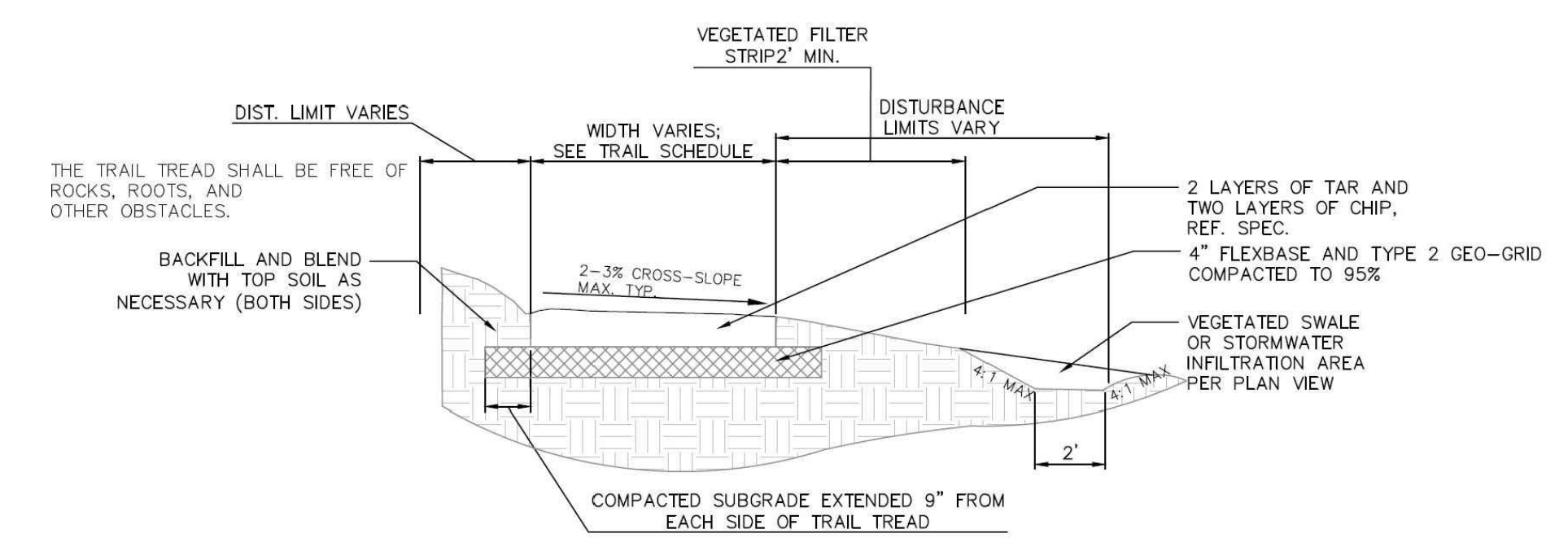

7 OPTIMIZED CHIP SEAL TRAIL-TYPICAL

ISSUED SETS		
Date	Description	
01/05/2024	DD SUBMITTAL For Review Only	
REVISIONS		
No.	Date	Description

LANDSCAPE ARCHITECT
BENDER WELLS CLARK DESIGN
 830 N. ALAMO ST.
 SAN ANTONIO, TEXAS 78215

Landscapes Architecture
Urban Design
Planning

830 North Alamo Street
 San Antonio, Texas 78215
 210-692-9221
 www.bwcdesign.com

© 2023 Bender Wells Clark Design
 All rights reserved. No part of this document may be reproduced or utilized in any form without prior written authorization of Bender Wells Clark Design.

O. P. Schnabel Bike Park
Bike Park
2022 Bond Improvements

9700 Rochelle Road
San Antonio Tx 78240

This drawing and the design were prepared specifically for this site and client and does not apply to any other projects. The reuse of this drawing for any other project is prohibited. Use of this set of drawings requires appropriate authorization from Bender Wells Clark Design.

LANDSCAPE ARCHITECT'S LICENSURE

THESE DOCUMENTS ARE INCOMPLETE AND ARE RELEASED FOR INTERIM REVIEW ONLY, AND NOT INTENDED FOR REGULATORY APPROVAL, BIDDING, PERMIT, OR CONSTRUCTION PURPOSES.

Drawn By : MM/ MJ Checked By : MM

SHEET TITLE & NUMBER:
 SKILLS COURSE
 DETAILS

BP-06.03

1 TYPICAL SANDSTONE (OR EQUAL) FEATURES



2 TYPICAL ARMORING DETAILS

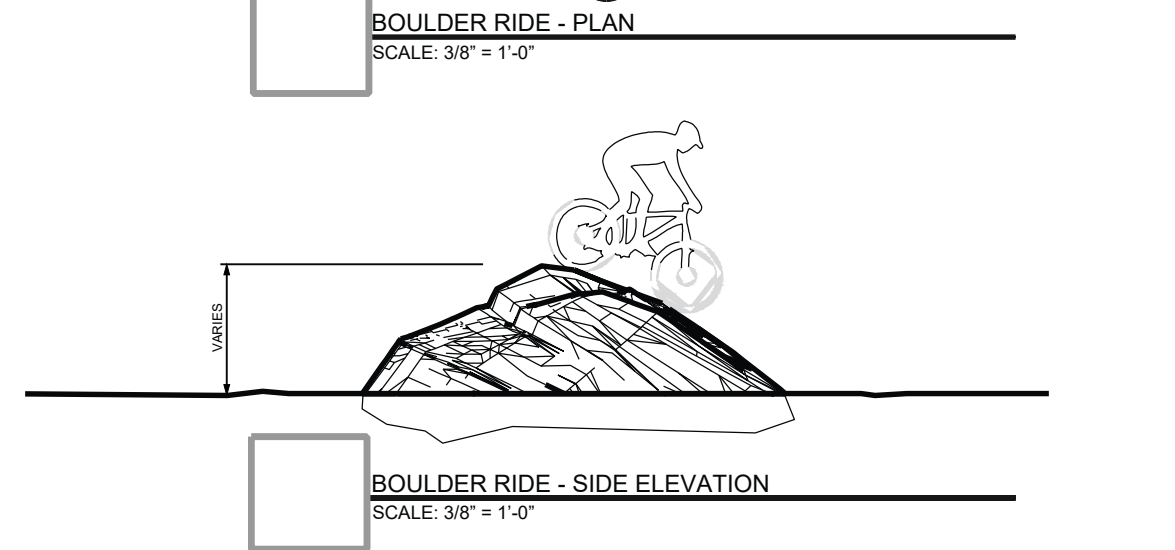
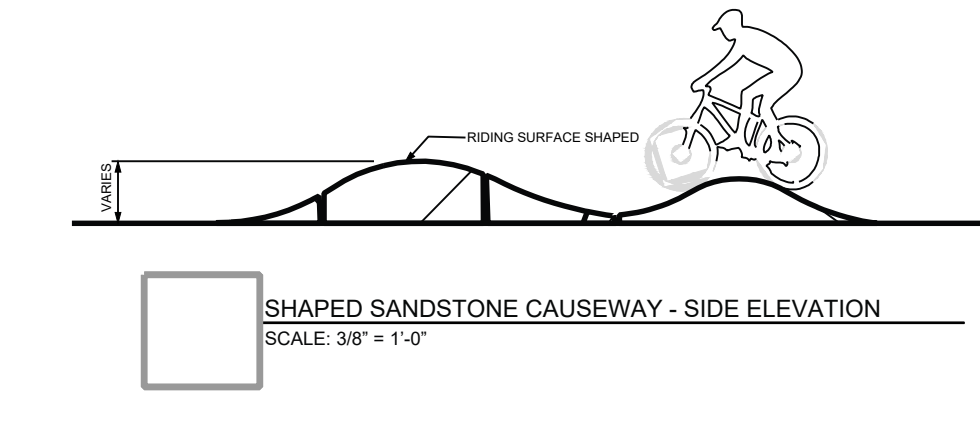
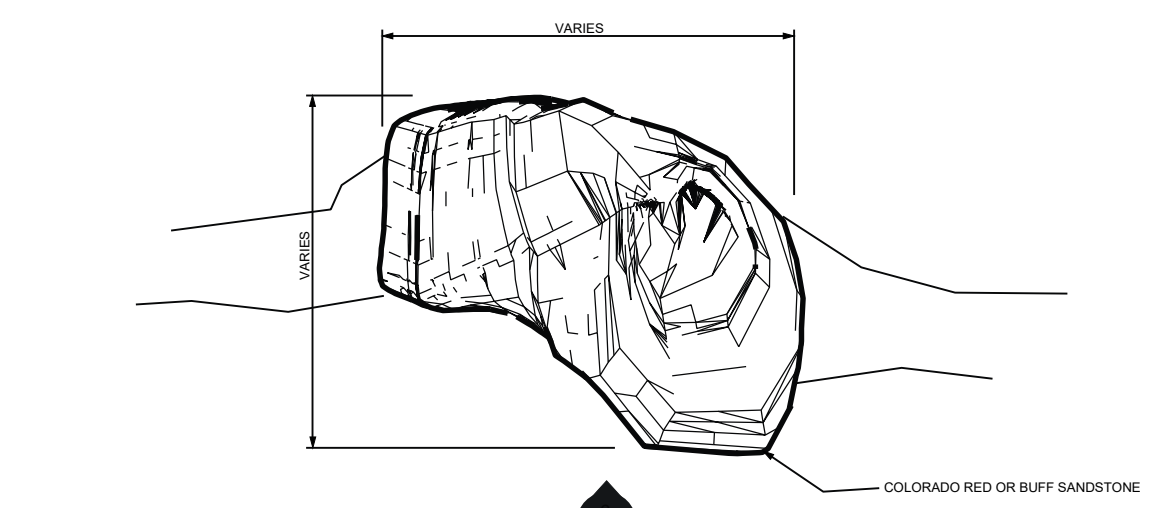
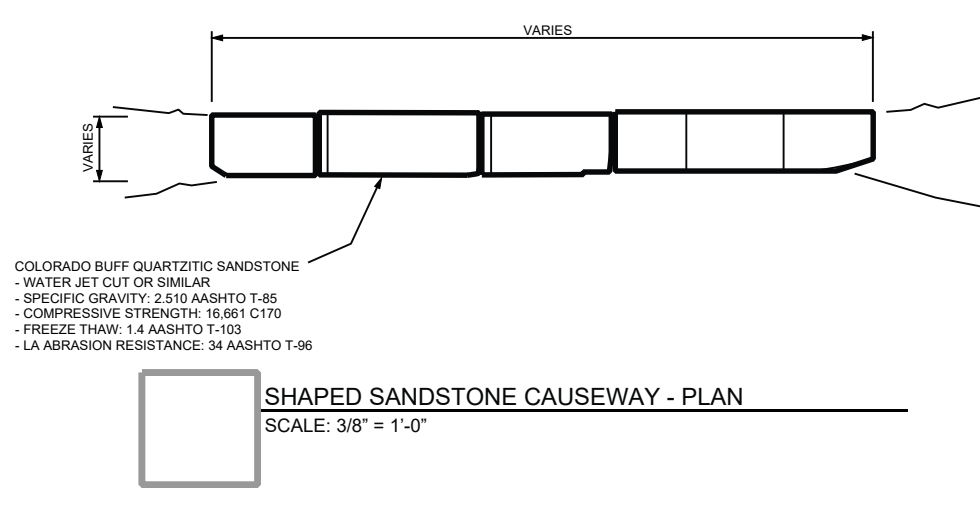
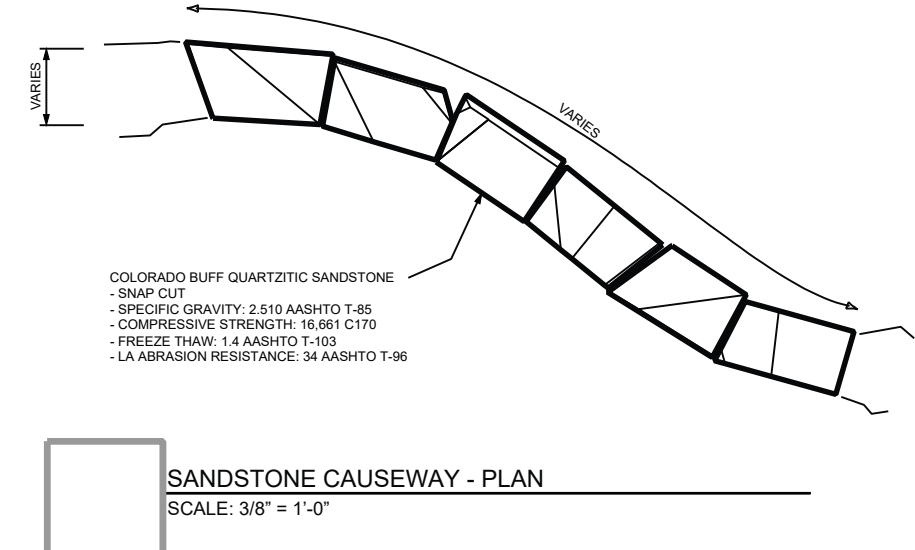
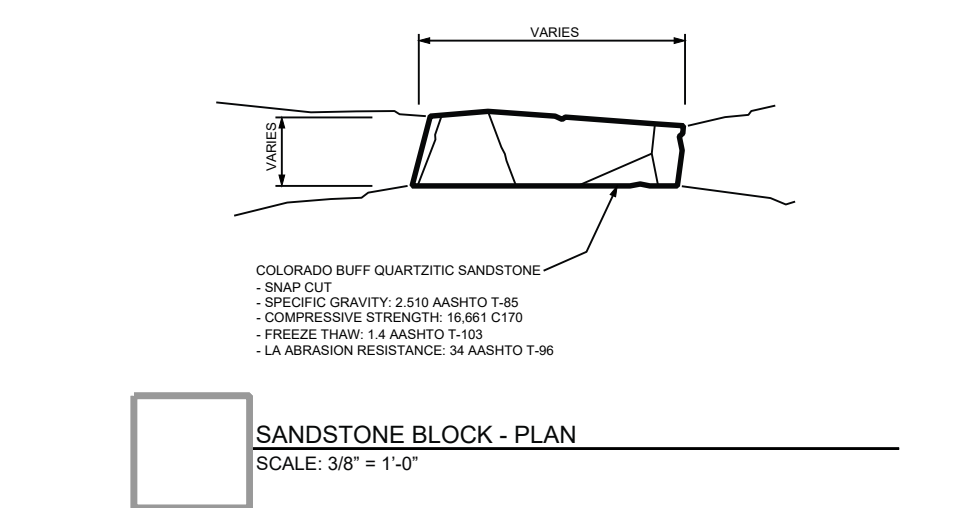

NOTES:
 ALL EXPOSED STONE, CRUSHED STONE, AND CRUSHER FINES TO BE COLORADO RED SANDSTONE.
 TEXTURE AND DIFFICULTY OF ARMORING SHOULD MATCH THE TRAIL CHARACTER AND DIFFICULTY.
 CONTRACTOR TO SUBMIT SAMPLE OF ROCK PRIOR TO CONSTRUCTION.
 ALL STONES SHOULD BE RECTANGULAR SHAPED AND MIXED SIZES FROM 2" TO 34" THICK, 12" TO 48" WIDE, AND MINIMUM 8" DEEP WHEN PLACED.
 STAGGER GUIDE ROCKS (24" MIN DIA BOULDERS) EVERY APPX 6' TO KEEP USERS ON ARMORING AS NECESSARY.

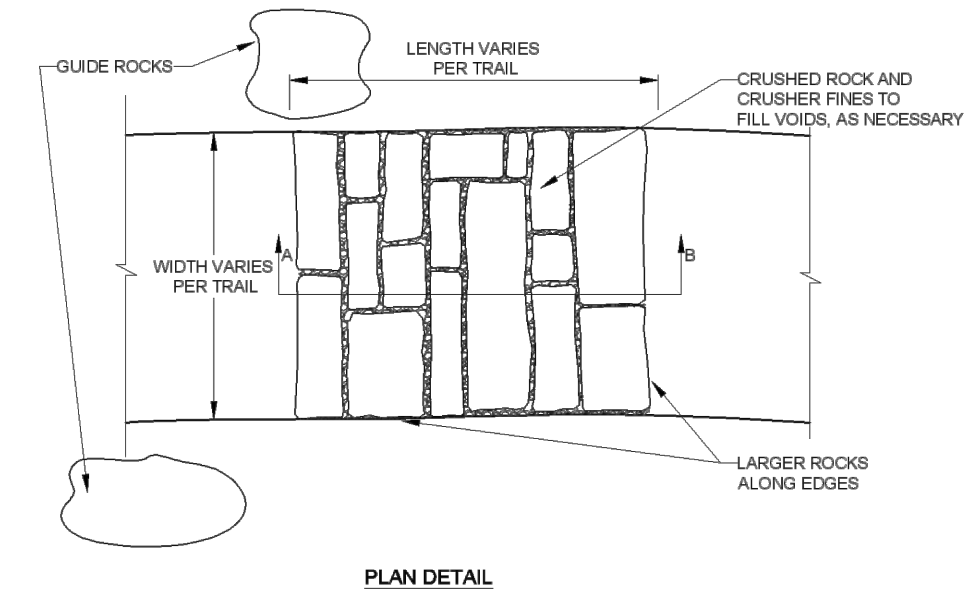
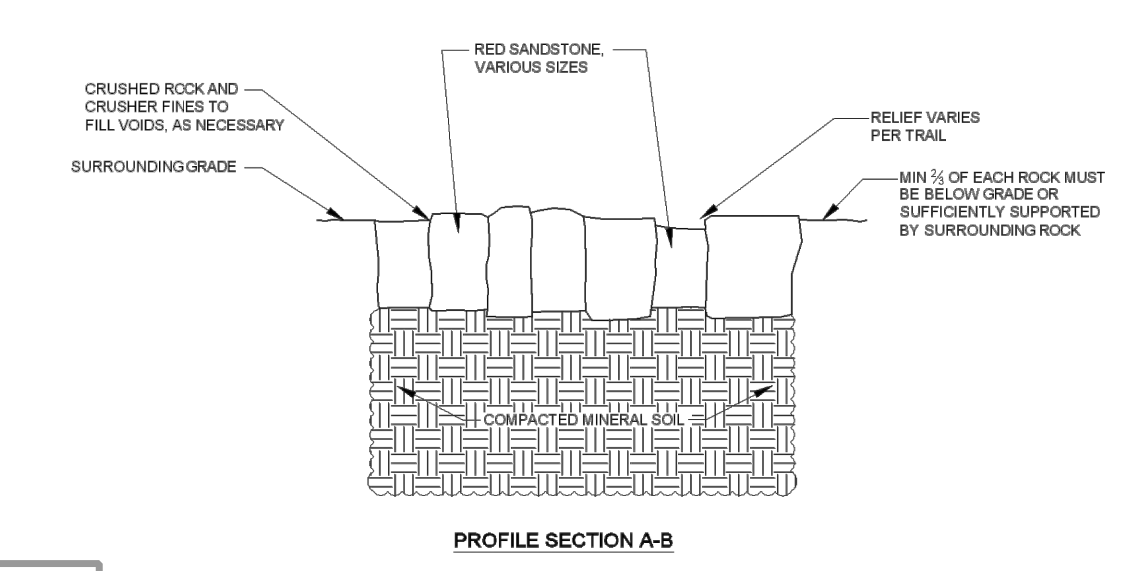

NOTES:
 ALL EXPOSED STONE, CRUSHED STONE, AND CRUSHER FINES TO BE COLORADO RED SANDSTONE.
 TEXTURE AND DIFFICULTY OF ARMORING SHOULD MATCH THE TRAIL CHARACTER AND DIFFICULTY.
 CONTRACTOR SHALL SUBMIT SAMPLE OF ROCK PRIOR TO CONSTRUCTION.
 STAGGER GUIDE ROCKS (24" MIN DIA BOULDERS) EVERY APPX 6' TO KEEP USERS ON ARMORING AS NECESSARY.

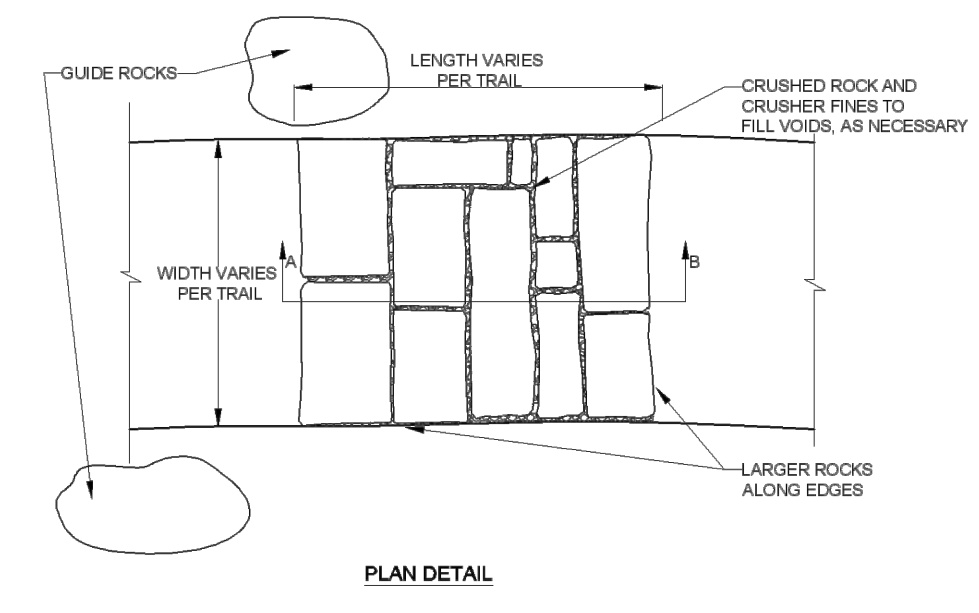
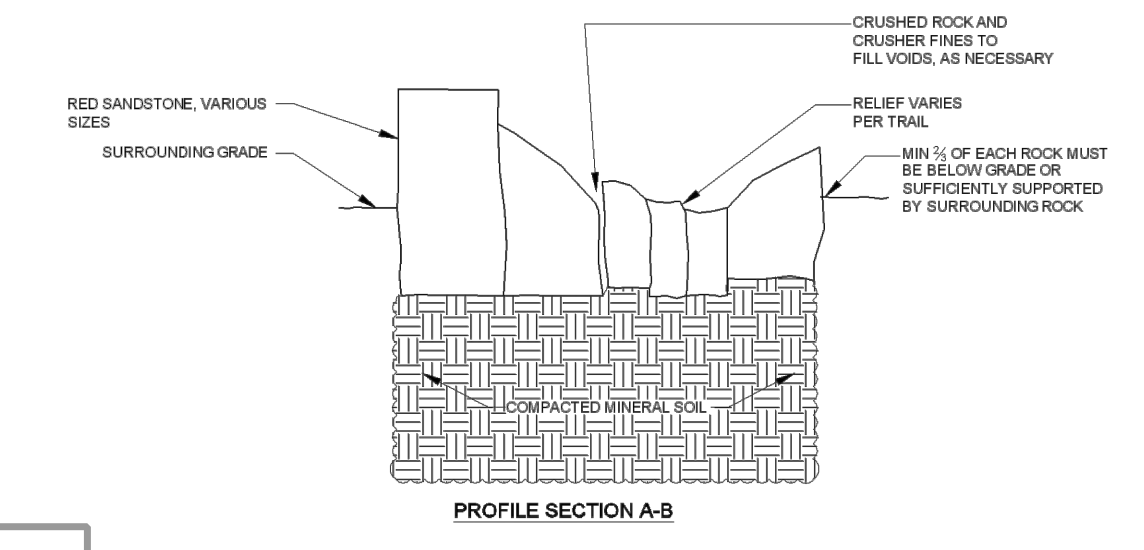

NOTES:
 RIVER ROCK TO BE ROUNDED WITH SMOOTH AND ROUND SURFACE EXPOSED.
 TEXTURE AND DIFFICULTY OF ARMORING SHOULD MATCH THE TRAIL CHARACTER AND DIFFICULTY.
 CONTRACTOR SHALL SUBMIT SAMPLE OF ROCK PRIOR TO CONSTRUCTION.
 INTENT IS A BUMPY SURFACE WITHOUT SHARP EDGES TO ALLOW ALL TYPES OF RIDERS.
 STAGGER GUIDE ROCKS (24" MIN DIA BOULDERS) EVERY APPX 6' TO KEEP USERS ON ARMORING AS NECESSARY.

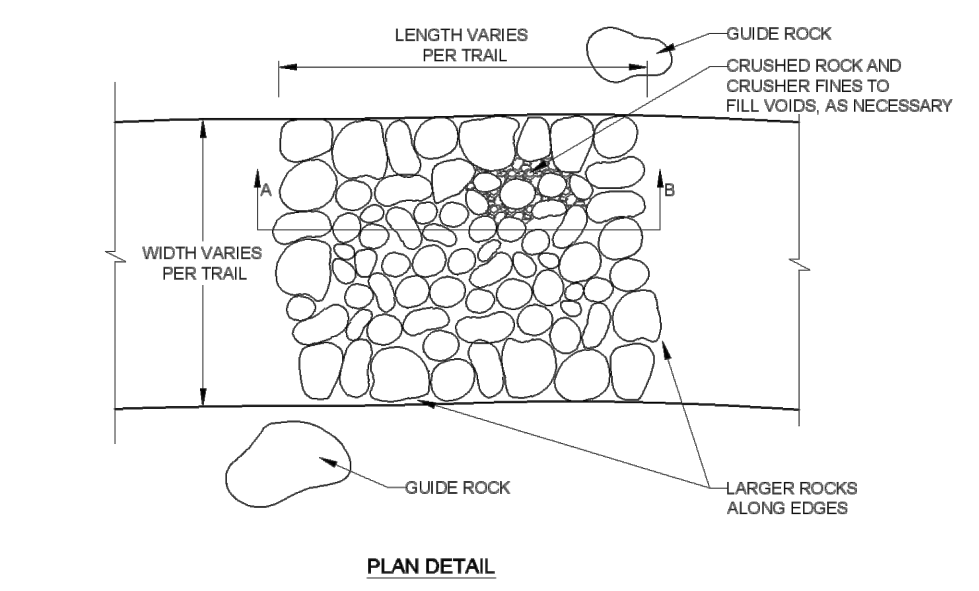
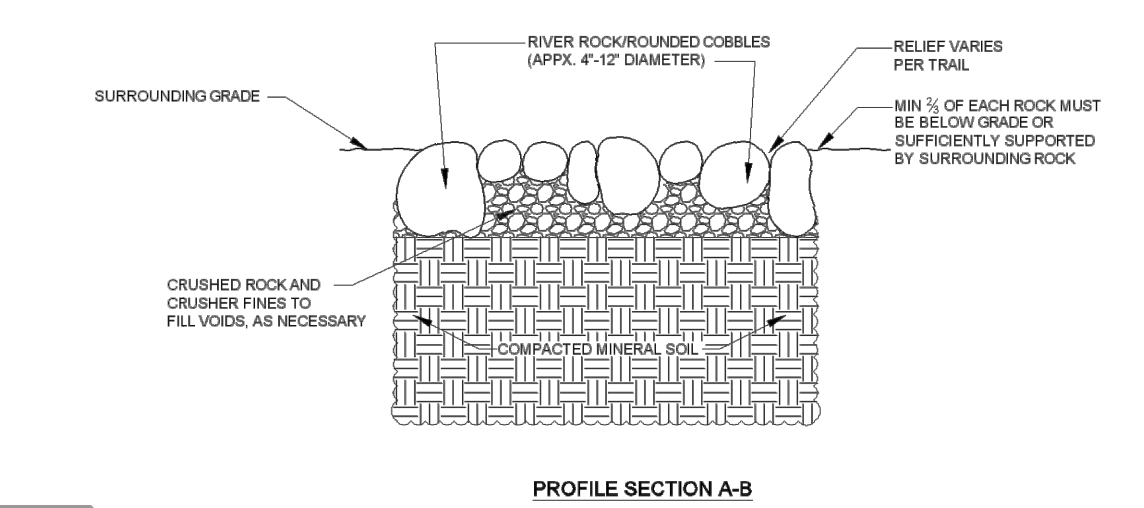

ISSUED SETS		
Date	Description	
01/05/2024	DD SUBMITTAL For Review Only	
REVISIONS		
No.	Date	Description

LANDSCAPE ARCHITECT
BENDER WELLS CLARK DESIGN
 830 N. ALAMO ST.
 SAN ANTONIO, TEXAS 78215

Landscape Architecture
Urban Design
Planning

830 North Alamo Street
 San Antonio, Texas 78215
 210-692-9221
 www.bwcdesign.com

© 2023 Bender Wells Clark Design
 All rights reserved. No part of this document may be reproduced or utilized in any form without prior written authorization of Bender Wells Clark Design.

O. P. Schnabel Bike Park
Bike Park
2022 Bond Improvements

9700 Rochelle Road
San Antonio Tx 78240

This drawing and the design work herein are prepared specifically for this site and client and does not apply to any other projects. The reuse of this design work for any other project is prohibited. Use of this set of drawings requires appropriate authorization from Bender Wells Clark Design.

LANDSCAPE ARCHITECT'S LICENSURE

THESE DOCUMENTS ARE INCOMPLETE AND ARE RELEASED FOR INTERIM REVIEW ONLY, AND NOT INTENDED FOR REGULATORY APPROVAL, BIDDING, PERMIT, OR CONSTRUCTION PURPOSES.

Drawn By : MM/ MJ Checked By : MM

SHEET TITLE & NUMBER:
 SKILLS COURSE
 DETAILS

BP-06.04

Date: Jan 05, 2024, 2:47pm User ID: Mitch
 File: C:\Users\Mitch\actionsportsdesign.com\PROJECTS - Documents\TX-San Antonio-OP Schnabel Bike Park-23-050-BP\04-Construction Documents\Sheet Files\BP-SIGNAGE DETAILS.dwg

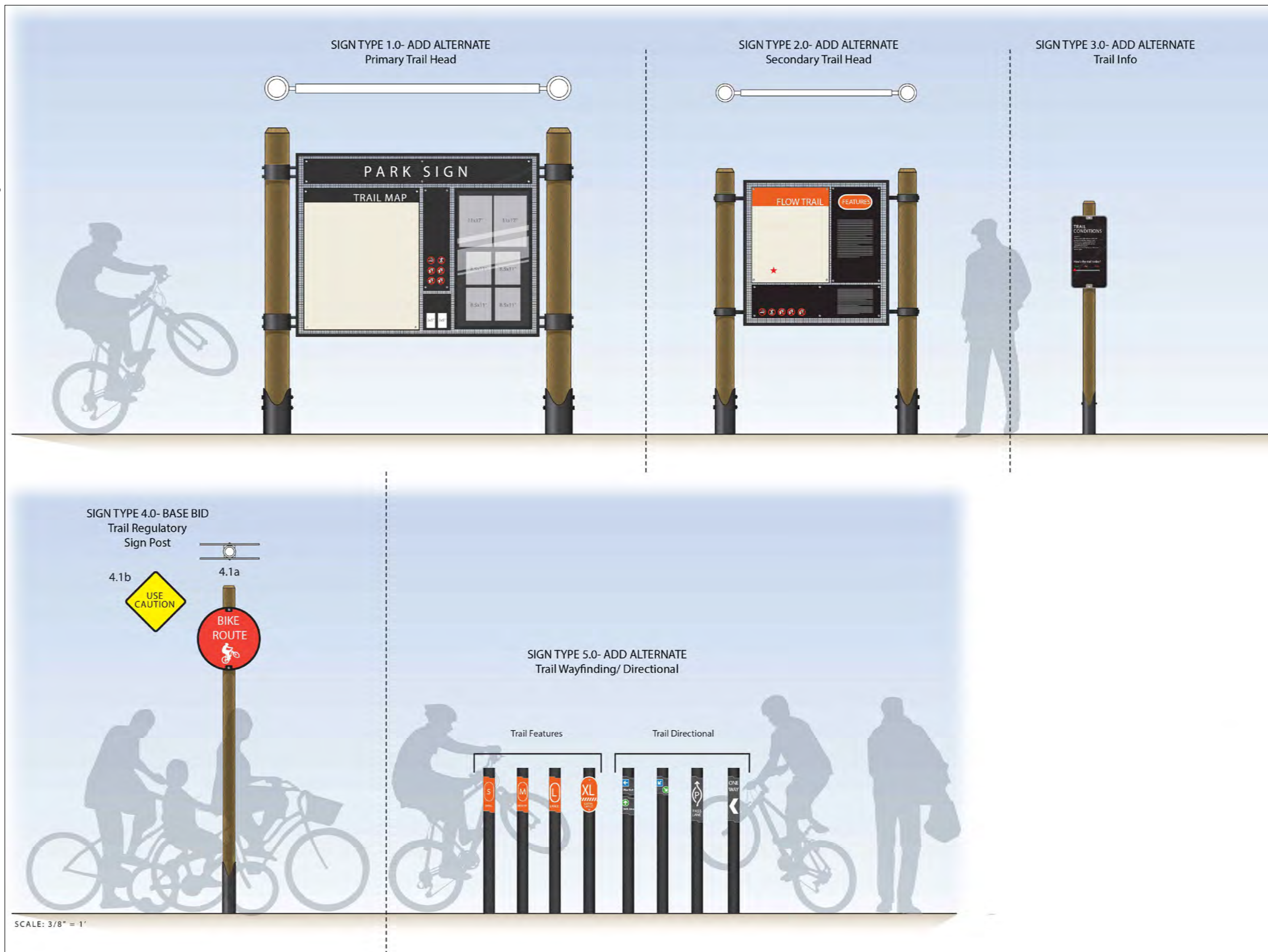

1 BIKE PARK SIGNAGE

PROJECT FONTS
 The Fabricator shall legally acquire at their own expense all project fonts from the specified distributors. Stantec will not provide copies of licensed fonts.
 Font Available from XX

TYPEFACE - Cholla Slab - Bold
 ABCDEFGHIJKLMNOPQRSTUVWXYZ
 abcdefghijklmnopqrstuvwxyz1234567890

TYPEFACE - Trade Gothic
 ABCDEFGHIJKLMNOPQRSTUVWXYZ
 abcdefghijklmnopqrstuvwxyz1234567890

PROJECT SYMBOLS

- Passing Lane
- One Way Arrow
- Easiest
- More Difficult
- Most Difficult
- Small Terrain Feature (S)
- Medium Terrain Feature (M)
- Large Terrain Feature (L)
- Extra Large Terrain Feature (XL)

PAINT & FINISHES
 All paints and finishes shall match exactly the color, finish, and the texture as noted.

- P-1 BLACK Mathevs Paint Color TBD
- P-2 GREEN Mathevs Paint Color TBD

OTHER MATERIALS
 All other materials shall match exactly the color, finish, and durability of the manufactures product as noted.

- M-1 Wood Post Color: Goldish Green All Weather Wood
- M-2 Steel Mesh Color: Black
- M-3 Carsonite Composite Sign Post Color: Black

PANTONE COLORS

- PANTONE XXXC (Green)
- PANTONE XXXC (Blue)
- PANTONE XXXC (Orange)
- PANTONE Black C

2 PARK TRAIL AND FEATURE SIGNAGE

ISSUED SETS

Date	Description
01/05/2024	DD SUBMITTAL For Review Only

REVISIONS

No.	Date	Description

LANDSCAPE ARCHITECT
BENDER WELLS CLARK DESIGN
 830 N. ALAMO ST.
 SAN ANTONIO, TEXAS 78215

Landscape Architecture
Urban Design
Planning

830 North Alamo Street
 San Antonio, Texas 78215
 210-692-9221
 www.bwcdesign.com

© 2023 Bender Wells Clark Design
 All rights reserved. No part of this document may be reproduced or utilized in any form without prior written authorization of Bender Wells Clark Design.

O. P. Schnabel Bike Park
Bike Park
2022 Bond Improvements

9700 Rochelle Road
San Antonio Tx 78240

This drawing and the design work represented herein are the property of Bender Wells Clark Design. The reproduction or use of this drawing for any other project, without the written consent of Bender Wells Clark Design, is prohibited. Use of this set of drawings requires appropriate authorization from Bender Wells Clark Design.

LANDSCAPE ARCHITECT'S LICENSURE

THESE DOCUMENTS ARE INCOMPLETE AND ARE RELEASED FOR INTERIM REVIEW ONLY, AND NOT INTENDED FOR REGULATORY APPROVAL, BIDDING, PERMIT, OR CONSTRUCTION PURPOSES.

Drawn By : MM/ MJ Checked By : MM

SHEET TITLE & NUMBER:
 WAYFINDING
 DETAILS

BP-07.01